



Technical File

Chapter 1 - Introduction

Cement-bonded particleboards

Office

Lisboa Oriente

Av. Infante Dom Henrique 337, 3rd Floor
1800- 210 LISBON, PORTUGAL

Factory

VIROC Portugal S.A.

National Road 10

Km 44.7, Vale da Rosa

2914-519 SETÚBAL, PORTUGAL

In/ investwood

www.investwood.pt



INDEX

1.	INTRODUCTION	5
1.1	Description	5
1.2	Materials used in manufacturing.....	5
1.3	Dimensions	5
1.4	Cutting tolerances	5
1.5	Colours	6
1.6	Thicknesses and thickness tolerances	9
1.7	Mechanical features.....	9
1.8	Other features	10
1.9	Sound isolation	10
1.10	Weight.....	11
1.11	Packaging	11
1.12	Quality control in production.....	11
1.13	Pallet labelling	12
1.14	Varnishing and painting	13
1.15	Cutting	13
1.16	Drilling.....	14
1.17	Edge machining	14
1.18	Surface polishing.....	15
1.19	Sanded surfaces.....	15
1.20	Storage.....	16
1.21	Handling	16
1.22	Acclimatisation.....	17
1.23	Application	17
1.24	Colour variation	17
1.25	Maintenance	18
1.26	Technical support.....	18
1.27	Declaration of Performance (DoP).....	18

INDEX OF TABLES AND FIGURES

Figure 1.1 - Viroc Grey	6
Figure 1.2 - Black Viroc.....	6
Figure 1.3 - White Viroc	7
Figure 1.4 - Yellow Viroc	7
Figure 1.5 - Red Viroc	8
Figure 1.6 – Ochre Viroc.....	8
Figure 1.7 - Circular saw with tungsten cutting disc	14
Figure 1.8 - HSS drill and bits (for drilling metal)	14
Figure 1.9 - Electric edge milling cutters for machining edge process	14
Figure 1.10 - Bevel, groove and notch.	15
Figure 1.11 – Tongue and groove and half-lap.....	15
Figure 1.12 - Orbital sander and cleaning disk	15
Figure 1.13 - Storage of Viroc panels	16
Figure 1.14 - Viroc panels Handling.....	16
Figure 1.15 - Upper panel warping	17



TABLE.....	18
Summary of applications by thickness.....	18
Table 1 - Summary of applications by thickness	18

Credits

Author

Mr José Pinheiro Soares,

suporte.tecnico@investwood.pt

Review and English Translation

CS Traduções

geral@cstraducoes.pt

Viroc Portugal S.A. reserves the right to modify this document without prior notice.

This technical document invalidates all previous technical documents.

Issue: February 15, 2024

1. INTRODUCTION

1.1 Description

Viroc is a composite panel made from a mixture of cement and wood, known as the Cement Bonded Particle Board (CBPB). It combines the flexibility of wood with the strength and durability of cement, permitting a wide range of applications, both indoors and outdoors. The production of the Viroc panel complies with the specifications of the EN634 and EN13986 Standards and has a CE Marking Certificate.

The Viroc panel has a heterogeneous appearance with different shades dispersed randomly, which are the result of the natural colours of the raw materials used and the chemical reactions.

The surfaces may show some irregularities, such as small incrustations, dirt, stains, scratches, salts (efflorescence) and small wood chips.

Whenever the panel is to be exposed, even if a varnish finish is not foreseen, the surface that will be visible must be cleaned/polished with a cleaning disk to remove any imperfections.

Differences in tone may be observed on the same face, between the faces of the same panel or between the different productions.

The surfaces of the panels, if required, can be supplied polished. Polishing consists of cleaning the surface of salts, dust and some dirt derived from the manufacturing process, without altering the panel natural appearance. The panel will continue to retain its characteristic stains and colour heterogeneities.

If required, the panels can be supplied sanded. This operation consists of roughening the surfaces with coarse sandpaper in order to minimise the variation in thickness. Once sanded, the surfaces are left with visible wood particles. The sanded panel has no decorative features, so it can be seen.

The Viroc panel only has one side to show. When packaged, this is the side that faces upwards.

The Viroc panel is regarding fire reaction of class B-s1,d0 rating.

The Viroc A2 panel is regarding Fire reaction of class A2-s1,d0 rating.

1.2 Materials used in manufacturing

Percentage by dry weight:

Portland cement: 61,8%

Pine wood chips: 22,7%

Water: 10,7%

Non-toxic additives: 1,4%

Pigment: 3,4%

1.3 Dimensions

Manufacturing dimensions:

2600x1250 mm and 3000x1250 mm

1.4 Cutting tolerances

Length and width: ± 3 mm

Squarness: ≤ 2.0 mm/m

Edge straightness: ≤ 1.5 mm/m

1.5 Colours

The Viroc panel comes in 6 different colours. The colour of the panels results from the addition of a pigment to the mass during the manufacturing process. The Viroc panel has a heterogeneous appearance with different shades dispersed randomly, which are the result of the natural colours of the raw materials used and chemical reactions, see photographs 1.1 to 1.6.

For availability of colours and dimensions, see the Viroc panel data sheet.



Figure 1.1 - Viroc Grey



Figure 1.2 - Black Viroc



Figure 1.3 - White Viroc



Figure 1.4 - Yellow Viroc



Figure 1.5 - Red Viroc



Figure 1.6 – Ochre Viroc

1.6 Thicknesses and thickness tolerances

Raw and polished panel	
Thickness (mm)	Tolerance (mm)
8	± 0.7
10	± 0.7
12	± 1.0
16	± 1.2
19	± 1.5
22	± 1.5
25	± 1.5
28	± 1.5
32	± 1.5

1.7 Mechanical features

Features	Performance	Standard
Density Average value	≥ 1000 Kg/m ³ 1350 Kg/m ³	EN 323
Modulus of elasticity in bending: Class 2 Class 1 Average value	≥ 4000 N/mm ² ≥ 4500 N/mm ² 6000 N/mm ²	EN 310
Bending strength Average value	≥ 9 N/mm ² 12 N/mm ²	EN 310
Internal bond Average value	≥ 0.5 N/mm ² 0.8 N/mm ²	EN 319
Internal bond after cyclic testing	≥ 0.3 N/mm ²	EN 319 EN 321
Swelling 24h Average value	≤ 1.5% ≤ 0.8%	EN 317
Swelling after cyclic testing	≤ 1.5%	EN 317 EN 321

1.8 Other features

Reaction to Fire

Viroc: B-s1,d0 - Combustible but not flammable

Viroc: A2: A2-s1,d0 - Incombustible

Thermal conductivity

$\lambda = 0.22 \text{ W/(m.K)}$

Moisture

Outside at origin: 6 - 12%

Alkalinity

Surface alkalinity PH: 11 - 13

Formaldehyde

Class of formaldehyde: E1 (EN 13986-Annex B)

No formaldehyde added (NAF)

Amiante/Asbestos

Does not contain.

Pentachlorophenol

Does not contain.

Microcrystalline silica

Does not contain.

1.9 Sound isolation

Sound reduction index R_w (C;Ctr)

Thickness (mm)	R_w (C;Ctr) (dB)
8	31 (-1;-3)
10	32 (-2;-3)
12	33 (-1;-3)
16	35 (-2;-3)
19	35 (-1;-2)
22	37 (-2;-3)

1.10 Weight

Specific weight: Average value 1350 Kg/m³

Thickness (mm)	Weight per m ² (Kg/m ²)	Weight of panels	
		2600x1250 (Kg)	3000x1250 (Kg)
8	10.8	35.1	40.5
10	13.5	43.9	50.6
12	16.2	52.7	60.8
16	21.6	70.2	81.0
19	25.7	83.4	96.2
22	29.7	96.5	111.4
25	33.8	109.7	126.6
28	37.8	122.9	141.8
32	43.2	140.4	162.0

1.11 Packaging

Number of panels per pallet

Thickness (mm)	2600x1250 (mm)	3000x1250 (mm)
8	60	57
10	48	46
12	40	38
16	30	28
19	25	24
22	24	23
25	21	20
28	18	18
32	16	16

1.12 Quality control in production

VIROC Portugal is a company with a CE Marking Certificate, so all the tests are carried out in order to comply with the characteristics required by European standards (EN).

Any material that does not comply with the requirements is considered "Non-Conforming" and is not marketed with the CE Marking Certificate.

In raw materials

- Measuring the wood logs sugar residues, in all loads, until the value conforms;
- Moisture from shavings, once a day.

During manufacturing

- Wood chip granulometry, once a day;
- Density and quantity of chemicals, once every 8 hours or whenever the tank is filled;
- Moisture of the mixture, twice per hour;
- Mattress thickness, continuous measurement;
- Temperature and moisture in the hardening tunnel, continuous measurement;
- Temperature and moisture in the drying tunnel, continuous measurement;

In the final product

- Thickness, on all panels;
- Dimensions, once every 2 hours or whenever the thickness changes: Length and width ± 3 mm;
- Squareness, once every 2 hours or whenever the thickness changes: ≤ 2 mm/m;
- Edges straightness, once every 2 hours or whenever the thickness changes: ≤ 1.5 mm/m;
- Density, once every 8 hours or whenever the thickness or the colour changes: ≥ 1000 Kg/m³;
- Bending strength, once every 8 hours or whenever the thickness or the colour changes: ≥ 9 N/mm²;
- Modulus of Elasticity, once every 8 hours or whenever the thickness or the colour changes: of Class 2 ≥ 4000 N/mm², of Class 1 ≥ 4500 N/mm²;
- Internal bond, once a day or whenever the thickness or the colour changes: ≥ 0.5 N/mm²;
- Swelling 24h, once a day or whenever the thickness or the colour changes: ≤ 1.5 %;
- Internal bond after cyclic testing, once a week: ≥ 0.3 N/mm²;
- Swelling after cyclic testing, once a week: ≤ 1.5 %;
- Moisture in the panels after drying, once every 8 hours or whenever the thickness or the colour changes.

1.13 Pallet labelling

All pallets are labelled with the following information:

- Name and address of the manufacturer;
- Type of panel, Raw or Sanded;
- CE Marking logo with the certificate number;
- Thickness;
- Colour;
- Dimensions;
- Edging, normal cutting or tongue and groove/half-lap machining;
- Number of panels;
- Volume number.

1.14 Varnishing and painting

Viroc panels should be painted or varnished to improve their resistance to weather exposure. They can also be painted for decorative purposes. VIROC Portugal S.A. recommends sealing the panel with a varnish or paint, particularly when the panel is applied outdoors, in order to seal the pores and protect it from the effects of sun radiation, rain and temperature variations. Sealing the panel on all faces and edges increases durability and dimensional stability.

Panels that have not been painted/varnished are more likely to show drips and efflorescence stains. These efflorescences can be cleaned by mechanically polishing them with an abrasive cleaning disc. It is not always possible to completely remove these stains or drips.

Panels that are not painted or varnished have greater dimensional variation. Under extreme conditions, the shrinkage of the panel could be 0.5% (5 mm/m) and the panel could warp out of plane.

Before applying paint or varnish, the panel surfaces must be clean of dirt, dust, grease and efflorescence. The panels can be cleaned by polishing them with an abrasive cleaning disc, or alternatively with a paper sandpaper with a grit of 120 or more. Cleaning must be careful to avoid excessive sanding of the surface, which could remove the layer of the fines and expose the wood fibres, altering the appearance of the panel.

Paint or varnish must be applied to both sides and tops of the panels, applying the coats recommended by the manufacturer.

There are no specific paints or varnishes to be applied to Viroc. The panel has a surface alkalinity (PH) of 11 to 13, so paints and varnishes suitable for concrete and wood surfaces at the same time are usually the best when applied to Viroc panel.

Paints and varnishes made from acrylic resins or solvent-based aliphatic polyurethanes are the ones that have shown the best performance. Water-based acrylic resin or aliphatic polyurethane varnishes have the least effect on the panel original colour.

In addition to the above, paints and varnishes must be suitable for their intended purpose. For example, if it is a façade, the paint/varnish must be suitable for use on exterior walls, and if it is a floor, the paint/varnish must be hard and resistant enough for this application.

Generally speaking, varnishes are easy to apply, but it is very important to bear in mind that the application must be continuous and constant, to ensure that the finish is homogeneous on the panel and that the surface does not become stained and have different shades. The panels must always be painted/varnished on both sides and tops, and the application procedures, supplied by the respective manufacturers, must always be followed for the recommended coats.

1.15 Cutting

The panels can be cut, drilled and machined with electric or compressed air tools, normally used in carpentry or mechanical locksmith shops.

Cutting, drilling and machining Viroc panels releases dust that may contain traces of silica and cementitious material, so the appropriate individual protective equipment such as masks, gloves, goggles, etc. should be used.

Viroc panels should be cut using circular saws with high wear-resistant carbide (tungsten) or diamond cutters (see figure 1.7). To make multiple cuts or cut panels with a thickness of 19 mm or more, a horizontal cutting table should be used. The cutting table will make the cutting work more effective.

Frezite (www.frezite.pt) has saw blades suitable for cutting Viroc panels.

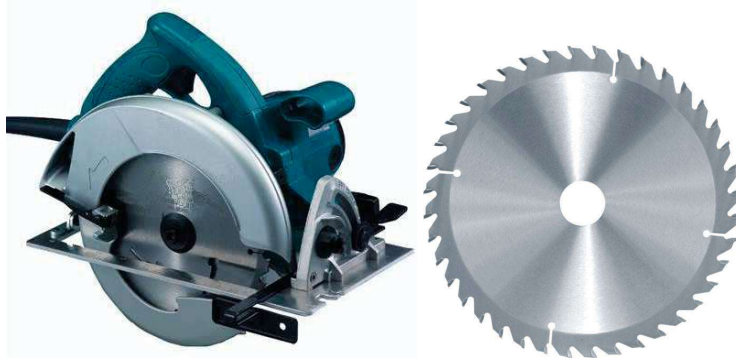

Figure 1.7 - Circular saw with tungsten cutting disc

1.16 Drilling

Drilling must be carried out with drills in "non-impact" mode using HSS (High Speed Steel) bits suitable for drilling metal (see figure 1.8).

Frezite (www.frezite.pt) has drill bits suitable for drilling Viroc panels.



Figure 1.8 - HSS drill and bits (for drilling metal)

1.17 Edge machining

Simple edge machining can be carried out on site using portable edge milling cutters (see figure 1.9).

Using the right cutters, you can make edges with: Bevelling, grooving, notching, etc. (see figure 1.10).

The edges of the panels can be supplied with factory-made notches, tongue-and-groove or half-lap (see figure 1.11).



Figure 1.9 - Electric edge milling cutters for machining edge process



Figure 1.10 - Bevel, groove and notch.

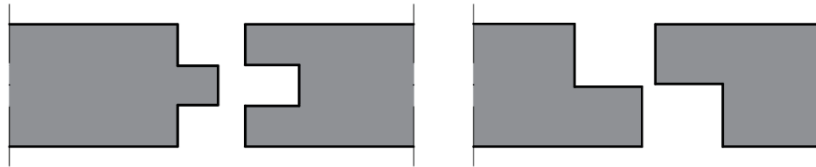

Figure 1.11 – Tongue and groove and half-lap

1.18 Surface polishing

Polishing consists of cleaning the surface of the salts, dust and some dirt derived from the manufacturing process, without altering the panel natural appearance. The panel will retain the stains and heterogeneities that characterise it.

When required, the Viroc panel can be supplied polished at the factory. However, this operation will be carried out on site.

On-site polishing is achieved with an orbital sander using abrasive cleaning discs (see figure 1.12).

The cleaning discs are made of an abrasive polypropylene fibre, Scotch Brite, which removes dirt without damaging the surface layer of the panel.

Alternatively, sandpaper discs with a grit of 120 or more can be used.

Care must be taken when cleaning with sandpaper to avoid removing the layer of the fines from the panel surface and exposing the wood fibres.



Figure 1.12 - Orbital sander and cleaning disk

Video illustrating the cleaning of a panel with an orbital sander:

<https://www.youtube.com/watch?v=HeQZNVNOZYI>

1.19 Sanded surfaces

On request, Viroc panels can be supplied sanded, such as the Viroc Floor panel. This operation consists of roughening the surfaces with coarse sandpaper in order to minimise the variation in thickness. Once sanded, the surfaces show visible wood particles. The sanded panel has no decorative features, so it can be seen.

Panels calibrated on both sides have a thickness tolerance of ± 0.3 mm.

1.20 Storage

When ready for transportation, the panels are protected by a waterproof plastic screen. The side edges are protected with L-shaped cardboard, including those in contact with the packaging system straps. The pallet protectors should only be removed to acclimatise the panels to the application site.

Viroc panels should be stored in a covered area, protected from sunlight and rain, with a flat horizontal base. The pallets will be placed on supports that must be high enough (≥ 8 cm) to allow easy access by a forklift. The maximum distance between supports should not exceed 800 mm and the maximum distance between the 1st support and the top of the pallet should not exceed 210 mm.

If the pallets are stacked on top of each other, all the support bases must be aligned vertically to avoid deformation.

You can stack up to 6 pallets at a maximum height of 4 metres (see figure 1.13).

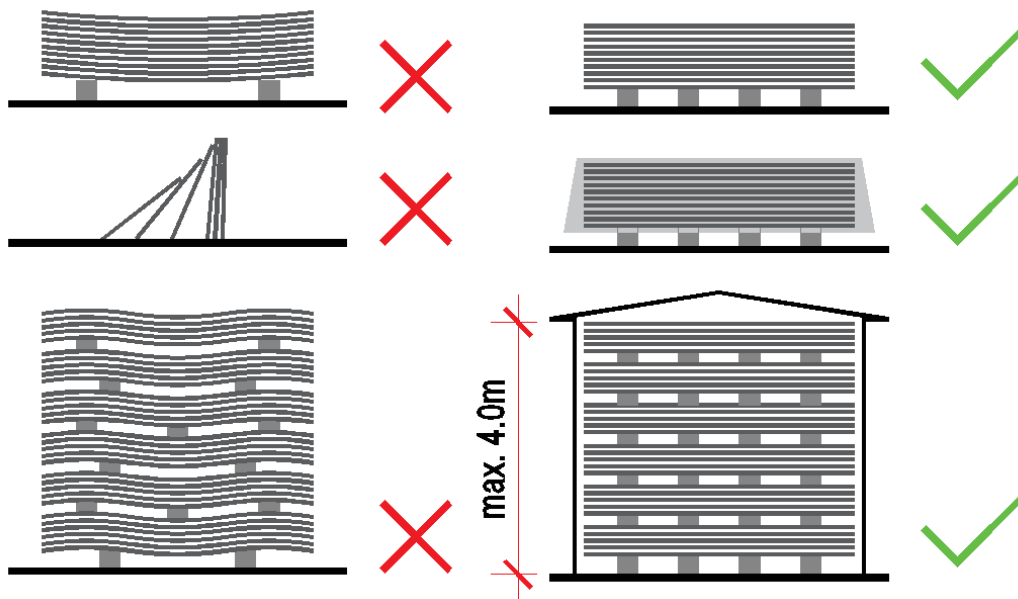

Figure 1.13 - Storage of Viroc panels

1.21 Handling

Whenever possible, panels should be handled using the appropriate equipment, such as forklifts, plate elevators, etc.

If the panels have to be moved manually, this process has to be carried out panel by panel, in a vertical position, so that they remain flat without deforming (see figure 1.14).

The panels have the weight indicated in section 1.10, so they should not be moved manually unless there are enough persons on site to perform it.

Good manual handling practices should be followed, using the appropriate personal security equipment and following the rules of the European Health and Safety legislation, Osha.Europa.eu (Factsheet 73):

<https://osha.europa.eu/pt/tools-and-publications/publications/factsheets/73/view>



Figure 1.14 - Viroc panels Handling

1.22 Acclimatisation

When it leaves the factory, the panel moisture level ranges from 6 to 12%.

To ensure proper installation conditions, the panel must adapt to the temperature and moisture conditions of the installation site. To do this, cut the straps around the pallets and remove the protective plastic sheeting. The panels should be left for at least 72 hours (3 days) to acclimatise to the installation site before being applied.

The panels at the top of the pallets, whose straps have already been removed, may warp, forming a concavity facing upwards. This phenomenon is natural and occurs due to the differential loss of moisture between the two surfaces. However, the process is reversible. The panel becomes flat again when both surfaces reach moisture equilibrium. To do this, you need to turn the back of the panel upwards and keep it that way until the balance is achieved. The same effect will be achieved by wetting the concave face (surface facing upwards) with water (see figure 1.15).

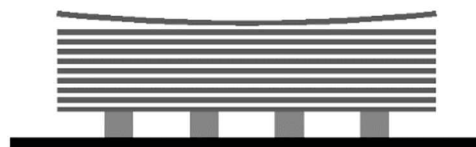

Figure 1.15 - Upper panel warping

1.23 Application

VIROC Portugal S.A. is the manufacturer of Viroc panels and does not apply them; the panels can be purchased from an authorised distributor directly by the contractors or subcontractors who carry out the application.

VIROC Portugal S.A. only supplies the panels. The fixings, structure and any other element can be purchased directly by the application company, provided they meet all the features specified in this Technical File.

Table 1 summarises the recommended thicknesses for each application.

1.24 Colour variation

When exposed to sunlight, the Viroc Panel undergoes slight colour changes, becoming a little lighter. This variation in tone depends on the colour.

In a colour evolution study carried out by the Polytechnic Institute of Viseu (IPV), the evolution of the panels when aged in different environments was measured.

The table below shows the average colour variations observed (Delta E) when exposed to the Xenon Chamber and QUV after 1500 hours of exposure.

Colour	Delta E	
	Xenon	QUV
Grey	7	2
Black	14	2
White	13	10
Yellow	6	1
Red	12	4
Ochre	13	3

1.25 Maintenance

Viroc panels are maintenance-free.

In outdoors applications where the panel is varnished or painted, an inspection should be carried out every 5 years to check that the varnishing or painting remains in good condition.

If no defects are found, a new inspection should be scheduled for five years later.

If there is marked wear or any deficiency in the varnish or paint applied to the panel, it should be cleaned with a jet of water with neutral detergent and repainted.

1.26 Technical support

VIROC Portugal S.A. has a Technical Department that can provide technical assistance during both the design and the execution phases of the project.

1.27 Declaration of Performance (DoP)

Under Regulation (EU) No. 305/2011 of the European Parliament and of the Council, which establishes harmonised conditions for the marketing of construction products, the Viroc panel holds a CE Marking Certificate and guarantees to comply with all the characteristics and properties declared in the declaration of performance.

The Declaration of Performance (DoP) is published on the Investwood website.

TABLE

Summary of applications by thickness

Application	Thickness (mm)								
	8	10	12	16	19	22	25	28	32
Façades			•	•					
Walls and wall cladding		•	•						
False ceilings	•	•	•						
Floor covering			•	•					
Beam-supported floors					•	•	•	•	•
Furniture	•	•	•	•	•	•	•	•	•

Table 1 - Summary of applications by thickness



Technical File

Chapter 2 - Façades

2.1 - Fixing with screws

Cement-bonded particleboards

Office

Lisboa Oriente

Av. Infante Dom Henrique 337, 3rd Floor

1800- 210 LISBON, PORTUGAL

Factory

VIROC Portugal S.A.

National Road 10

Km 44.7, Vale da Rosa

2914-519 SETÚBAL, PORTUGAL

In/ investwood

www.investwood.pt

INDEX

2.	VENTILATED FAÇADES.....	7
2.1	FIXING SYSTEM WITH SCREWS OR RIVETS.....	7
2.1.01	Wooden support structure	8
2.1.02	Galvanised steel support frame	8
2.1.03	Aluminium support frame	9
2.1.04	Galvanised steel support brackets.....	10
2.1.05	Aluminium support brackets	11
2.1.06	Anchors for fixing the support brackets	13
2.1.07	Bushings for fixing thermal insulation	14
2.1.08	Wooden upright protection strips	14
2.1.09	Screws for fixing the panels to a wooden structure	15
2.1.10	Screws for fixing the panels supported on a galvanised steel structure	15
2.1.11	Screws for fixing the panels supported on an aluminium structure.....	16
2.1.12	Rivets for fixing panels supported on a metal structure	16
2.1.13	Recommended thicknesses of the Viroc façade panels and their tolerance.....	17
2.1.14	Weight of panels.....	17
2.1.15	Viroc panel manufacturing dimensions and cutting tolerances	17
2.1.16	Maximum format of panels applied to a façade	18
2.1.17	Minimum format of panels applied to a façade	18
2.1.18	Façade Assembly operations	18
2.1.19	Marking and identification of the façade elements	18
2.1.20	Mounting the support brackets	18
2.1.21	Fixing the squares to the supporting wall	18
2.1.22	Angle plates.....	18
2.1.23	Fitting the thermal insulation	19
2.1.24	Mounting the support profiles	19
2.1.25	Fixing the profiles to the support brackets	19
2.1.26	Protection strips of the wooden uprights.....	21
2.1.27	Cutting Viroc panels.....	21
2.1.28	Drilling Viroc panels.....	22
2.1.29	Surface preparation of Viroc panels.....	22
2.1.30	Varnishing or painting Viroc panels	22
2.1.31	Fixing Viroc panels.....	23
2.1.32	Auxiliary assembly tools	27
2.1.33	Treatment of the joints	28
2.1.34	Air foil ventilation.....	28
2.1.35	Angle profiles	28
2.1.36	Cleaning the panels after application	29
2.1.37	Replacing a panel.....	29
2.1.38	Impact resistance.....	29
2.1.39	Wind action.....	30
2.1.40	Wind safety check.....	30
2.1.41	Example of Safety check of a Viroc panel to wind loads.....	30
2.1.42	Details, wooden structure	32
2.1.43	Details, galvanised steel frame.....	41
2.1.44	Details, Aluminium frame.....	50

INDEX OF TABLES AND FIGURES

Figure 2.1.1 - Wooden structure	8
Figure 2.1.2 - Galvanised steel profiles	9
Figure 2.1.3 - Galvanised steel profiles (Alternative)	9
Figure 2.1.4 - Aluminium structure	10
Figure 2.1.5 - Galvanised steel support brackets	10
Figure 2.1.6 - Aluminium support brackets	11
Figure 2.1.7 - Fixing the aluminium profiles to the support brackets	11
Figure 2.1.8 - Fixing the aluminium profiles to the support brackets	12
Figure 2.1.9 - Thermal cutting device for support brackets	12
Figure 2.1.10 - Plastic anchor of Ø10 mm	13
Figure 2.1.11 - M8 Metal anchor	13
Figure 2.1.12 - Bushing for fixing thermal insulation to the support structure	14
Figure 2.1.13 - Flexible PVC or EPDM protection strip.....	14
Figure 2.1.14 - Screws for wooden structure	15
Figure 2.1.15 - Screws for metal structures.....	16
Figure 2.1.16 - Rivets for fixing Viroc panels to a metal structure.....	17
Figure 2.1.17 - Constricting nozzle, to be screwed into the riveting tool mouth	17
Figure 2.1.18 - Auxiliary angle plate, galvanised steel Z350. Thickness: 2.5 mm	19
Figure 2.1.19 - Fixing the wooden uprights to the support brackets (2 screws of Ø≥6)	20
Figure 2.1.20 - Fixing the galvanised steel profiles to the support brackets	20
Figure 2.1.21 - Fixing the aluminium profiles to the support brackets	21
Figure 2.1.22 - Circular saw with tungsten cutting disc.....	21
Figure 2.1.23 - HSS drill and bits (for drilling metal).....	22
Figure 2.1.24 - Location of fixings and hole diameter	24
Figure 2.1.25 - Correct tightening and positioning of the screws	25
Figure 2.1.26 - Minimum distance from the screws to the edges of the beams	25
Figure 2.1.27 - Maximum panel size and location of fixings	26
Figure 2.1.28 - Correct tightening and positioning of the screws	27
Figure 2.1.29 - Correct positioning of screws or rivets.....	27
Figure 2.1.30 - Spanners for centering screws	27
Figure 2.1.31 - spanners for bolt holes-centering	27
Figure 2.1.32 - Tool for bolt holes-centering	28
Figure 2.1.33 - Perforated anti-rodent profile	28
Figure 2.1.34 - Corner angle profiles	29
Figure 2.1.35 - Corner angle profiles	29
Table 4 - Permissible pressure, distance of 600 mm between screws horizontally.....	31
Figure 2.1.36 - Vertical section, joint between panels	32
Figure 2.1.37 - Horizontal section, joint between panels.....	32
Figure 2.1.38 - Balcony finish.....	33
Figure 2.1.39 - Side finish	33
Figure 2.1.40 - Expansion joint	34
Figure 2.1.41 - Corner angle	34
Figure 2.1.42 - Corner angle	35
Figure 2.1.43 - Horizontal compartmentalisation of the air gap	35
Figure 2.1.44 - Detail of the base, anti-rodent grid.....	36
Figure 2.1.45 - Horizontal section, window opening	36
Figure 2.1.46 - Vertical section, window opening	37
Figure 2.1.47 - Detail of the top	38

Figure 2.1.48 - Fractionation of the structure: Profiles length ≤ 6 m	38
Figure 2.1.49 - Fractionation of the structure: Profiles length > 6 m	39
Figure 2.1.50 - Detail of the façade - false ceiling connection	40
Figure 2.1.51 - Vertical section, joint between panels	41
Figure 2.1.52 - Horizontal section, joint between panels	41
Figure 2.1.53 - Balcony finish	42
Figure 2.1.54 - Side finish	42
Figure 2.1.55 - Expansion joint	43
Figure 2.1.56 - Corner angle	43
Figure 2.1.57 - Corner angle	44
Figure 2.1.58 - Corner angle, variant	44
Figure 2.1.59 - Horizontal compartmentalisation of the air gap	45
Figure 2.1.60 - Detail of the base, anti-rodent grid	45
Figure 2.1.61 - Horizontal section, window opening	46
Figure 2.1.62 - Detail of the top	46
Figure 2.1.63 - Vertical section, window opening	47
Figure 2.1.64 - Fractioning the structure: Profiles length ≤ 6 m	48
Figure 2.1.65 - Fractioning the structure: Profiles length > 6 m	48
Figure 2.1.66 - Detail of the façade - false ceiling connection	49
Figure 2.1.67 - Vertical section, joint between panels	50
Figure 2.1.68 - Horizontal section, joint between panels	50
Figure 2.1.69 - Balcony finish	51
Figure 2.1.70 - Side finish	51
Figure 2.1.71 - Expansion joint	52
Figure 2.1.72 - Corner angle	52
Figure 2.1.73 - Corner angle	53
Figure 2.1.74 - Corner angle, variant	53
Figure 2.1.75 - Horizontal compartmentalisation of the air gap	54
Figure 2.1.76 - Detail of the base, anti-rodent grid	54
Figure 2.1.77 - Horizontal section, window opening	55
Figure 2.1.78 - Detail of the top	55
Figure 2.1.79 - Vertical section, window opening	56
Figure 2.1.80 - Fractionation of the structure: Profiles length ≤ 6 m	57
Figure 2.1.81 - Fractionation of the structure: Profiles length > 6 m	57
Figure 2.1.82 - Detail of the façade - false ceiling connection	58
WIND LOAD TABLES	59
Table 1 - Maximum pressure, 300 mm spacing between screws horizontally	59
Table 2 - Maximum pressure, 400 mm spacing between screws horizontally	59
Table 3 - Maximum pressure, 500 mm spacing between screws horizontally	60
Table 4 - Maximum pressure, 600 mm spacing between screws horizontally	60
Table 5 - Maximum pressure, 700 mm spacing between screws horizontally	61

Credits

Author

José Pinheiro Soares

suporte.tecnico@investwood.pt

Review and English Translation

CS Traduções

geral@cstraducoes.pt

Viroc Portugal S.A. reserves the right to modify this document without prior notice.

This Technical File invalidates all previous technical documents.

Issue: February 15, 2024



2. VENTILATED FAÇADES

Viroc panels can be used to clad the façade of buildings, forming a panel-ventilated façade.

Viroc panels have a heterogeneous appearance with differences in tone on the same face, between faces of the same panel or between different productions.

Surfaces may show some irregularities and incrustations.

When exposed to the sunlight, the colour of the panels changes slightly, becoming lighter. This variation in tone varies from colour to colour.

When applied to ventilated façades, Viroc panels must be varnished or painted, unless they are applied under the conditions described in Chapter 2.3.

The panels, when placed outdoors, are subject to dimensional variations of +1.0 mm to -3.0 mm per linear metre, when the panel is sealed on both sides and tops. The panel fixing system must allow for this dimensional variation.

Ventilated façades are made up of:

- Viroc panels
- Support structure for the panels and their fixing elements;
- Screws or rivets for fixing the panels to the support structure;
- Thermal insulation;
- Ventilation air layer;
- Complementary profiles for the treatment of singular points.

2.1 FIXING SYSTEM WITH SCREWS OR RIVETS

In this system, the Viroc panels that constitute the façade are fixed to a structure using screws or rivets.

In order to allow for dimensional variations in the panels without introducing stresses that could damage them, the fixing system must allow for dimensional variation with this in mind.

The panels must be pre-drilled and, in the peripheral fixings of the panel, the diameter of the bolt holes to be drilled for the installation of the screws must be 10 mm larger than the ones of the body of the screw, thus enabling shrinkage and expansion without introducing stress, creating expandable supports.

When fixing the central area of the panel, the diameter of the bolt holes must be the same as that of the body of the screw, fixing the panel rigidly by creating Fix supports. Your task is to ensure proper positioning.

The panel is fixed from the Fix supports in order to position the panel. Expansion supports should only be built later to avoid introducing stresses as the panels sag.

The screw fastening system consists of the following elements:

- a) Support structure made of wood, galvanised steel or aluminium and its fixing elements;
- b) Support brackets and their fixing elements;
- c) Thermal insulation;
- d) Screws for fixing the panels;
- e) Viroc panels

Support Structure

The support structure for the Viroc panels that will clad the façade can be made from wood, galvanised steel or aluminium profiles.

2.1.01 Wooden support structure

The wooden support structure is made up of pine wood beams, fixed to the load-bearing structure (wall) using galvanised or stainless steel support brackets, with metal anchors or anchors made up of metal screws and plastic bushings.

The strength of the wood used to make up the uprights, must be at least of class C18 according to EN 338, and its durability of class 2 or higher according to EN 335. Wood of durability of class 2 must be protected with a protective strip.

When assembled on site, wooden uprights must not have a moisture level of more than 18%, with a difference between consecutive elements of no more than 4%. The relative moisture of the wooden uprights is determined according to the method described in standard EN 13183-2, using a tip moisture metre.

The cross-section of the uprights is generally rectangular, with a minimum dimension of 40x50 mm (see figure 2.1.1).

These elements are dimensioned taking into account the deformations caused by climatic actions and other factors (temperature, humidity, wind, etc.), so that they do not jeopardise the normal functioning of the façade. The deformation resulting from wind loads (pressure or depression) must not exceed the L/200 limit of the span between support fixings.

The width of the uprights must be such that the fixings can be positioned correctly, with the capacity to absorb small positioning errors, so the screws must not be less than 15 mm from the end of the upright.

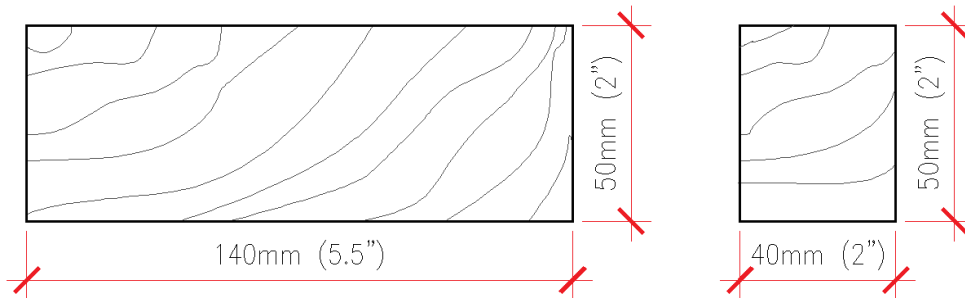

Figure 2.1.1 - Wooden structure

Minimum resistance of class C18 (EN 338) and durability of class 2 or higher (EN 335)

2.1.02 Galvanised steel support frame

The galvanised steel profiles are fixed to the load-bearing structure using galvanised or stainless steel support brackets, with metal anchors or anchors made up of metal screws and plastic bushes.

The strength of the steel used in the upright profiles must be minimum of class S220GD+Z, in accordance with standard EN 10346.

The hot-dip zinc coating (Z) should be 275 g/m² in coastal areas and 140 g/m² in other areas.

The section of the profiles is generally Omega, U or L-shaped with a minimum thickness of 1.5 mm. Other profile shapes can be used, provided they have the same performance and durability (see figures 2.1.2 and 2.1.3).

Note: The profiles used in plasterboard walls cannot be used, as the steel thickness is less than 1.5 mm.

Omega profiles are used at the intersection of 2 panels. U or L profiles are used as intermediate supports.

The sizing of these elements must take into account the deformations caused by climatic actions and other factors (temperature, hygrometry, wind, etc.), so that they do not jeopardise the normal functioning of the façade. The deformation resulting from wind loads (pressure or depression) must not exceed the L/200 limit of the span between support fixings.

The width of the profiles must be such that the fixings can be positioned correctly, with the capacity to absorb small positioning errors, and the screw must not be less than 10 mm from the end.

The distance between profiles must be such as to respect the maximum distance between panel fixings and the alignment of the profiles must be checked between adjacent elements and must not differ by more than 2 mm.

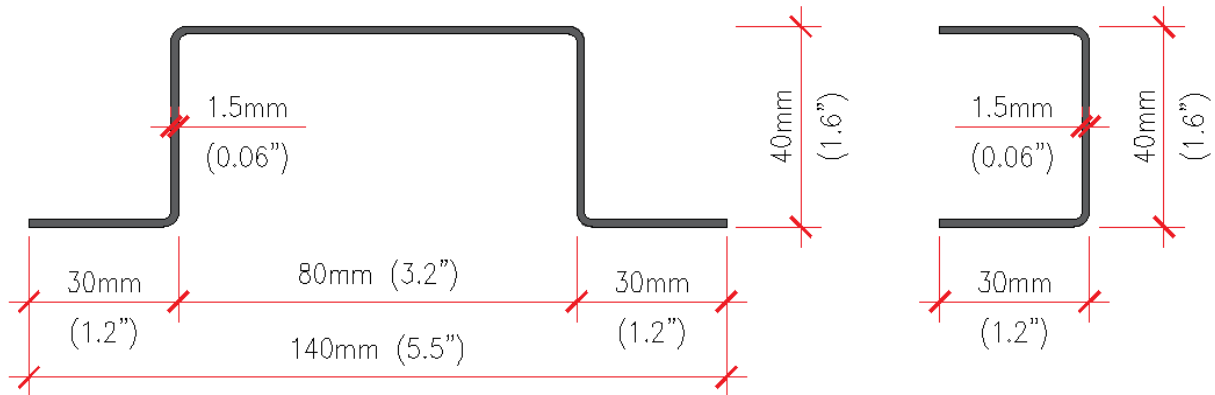

Figure 2.1.2 - Galvanised steel profiles
Minimum resistance of class S220GD (EN 10346)

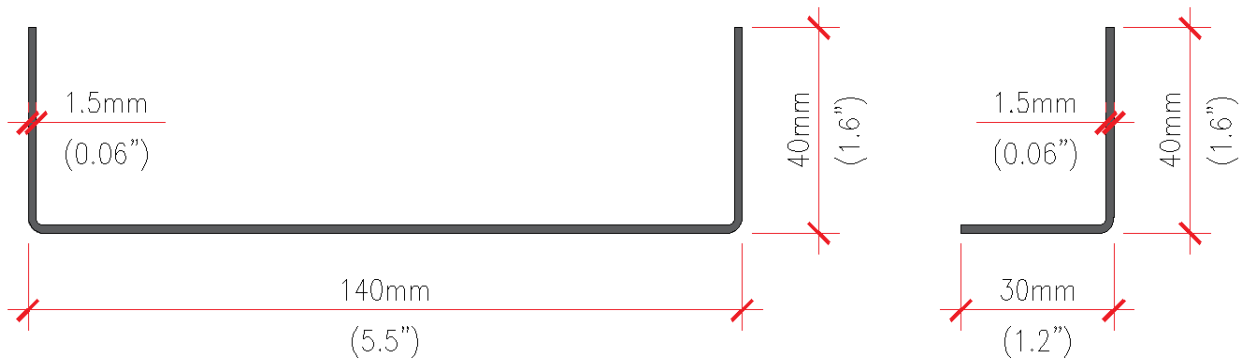

Figure 2.1.3 - Galvanised steel profiles (Alternative)
Minimum resistance of class S220GD (EN 10346)

2.1.03 Aluminium support frame

The aluminium profiles are fixed to the load-bearing structure using aluminium support brackets, with metal anchors or anchors made up of metal screws and plastic bushings.

The aluminium used in the profiles must be at least a 6000 series alloy, with a yield strength $R_{p0.2}$ greater than 180 MPa.

The section of the profiles is generally T or L-shaped with a minimum thickness of 2 mm. Other section shapes can be used, provided they have the same performance and durability.

T-shaped profiles are used at the intersection of 2 panels. L-sections are used as intermediate supports and are also used to create singular points in the façade (see figure 2.1.4).

The sizing of these elements must take into account the deformations caused by climatic actions and other factors (temperature, hygrometry, wind, etc.), so that they do not jeopardise the normal functioning of the façade. The deformation resulting from wind loads (pressure or depression) must not exceed the $L/200$ limit of the span between support fixings.

The width of the profiles must be such as to allow the fixings to be positioned correctly, with the capacity to absorb small positioning errors, and the screw must not be less than 10 mm from the end.

The distance between profiles must be such as to respect the maximum distance between panel fixings, and the alignment of the profiles must be checked between adjacent elements and must not differ by more than 2 mm.

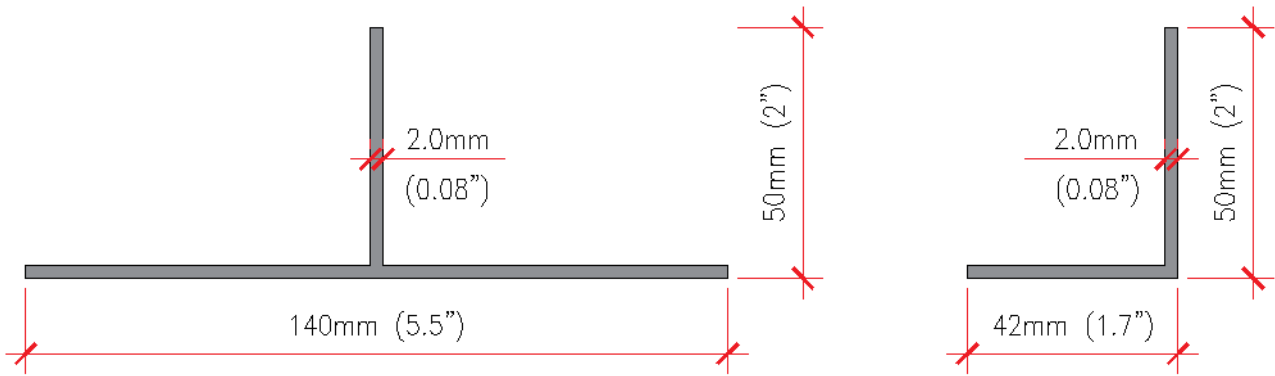

Figure 2.1.4 - Aluminium structure
6000 series alloy with $R_{p0.2} \geq 180$ MPa

2.1.04 Galvanised steel support brackets

The support brackets for fixing the wooden or galvanised steel structure are made of a durable metal alloy in galvanised steel, with a minimum strength of class S220GD, according to EN 10147.

In coastal areas, at a distance of 3 km from the sea, the support brackets must have special protection against corrosion, with a zinc weight of 275 g/m² or more, and can be made of stainless steel.

Support brackets are generally L-shaped, with several holes and a minimum thickness of 2.5 mm (see figure 2.1.5).

The support brackets are dimensioned taking into account the façade own weight, based on a partial security coefficient of 1.5. The vertical deformation of the bracket must not exceed 3 mm for the maximum vertical load.

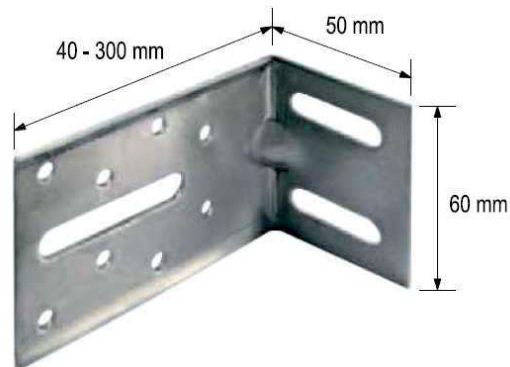

Figure 2.1.5 - Galvanised steel support brackets
Minimum resistance of class S220GD. Minimum thickness: 2.5 mm

2.1.05 Aluminium support brackets

The support brackets for fixing the aluminium structure are made of an aluminium alloy, which must be equal to or greater than 6060 T5. Support brackets are generally L-shaped, with several holes and a minimum thickness of 3 mm (see figure 2.1.6).

The support brackets are dimensioned taking into account the façade own weight, based on a partial security coefficient of 1.5. The vertical deformation of the bracket must not exceed 3 mm for the maximum vertical load.



Figure 2.1.6 - Aluminium support brackets
Alloy: 6060 T5, minimum thickness: 3 mm

Because aluminium has a high coefficient of expansion, the design of the structure must allow for the expansion of the profiles. In this sense, the aluminium profiles should not be longer than 6 m and there is only one point of attachment to the support brackets with restricted expansion movements, near the top end of the profile. The other fixings must allow the profiles to expand (see figures 2.1.7 and 2.1.8).

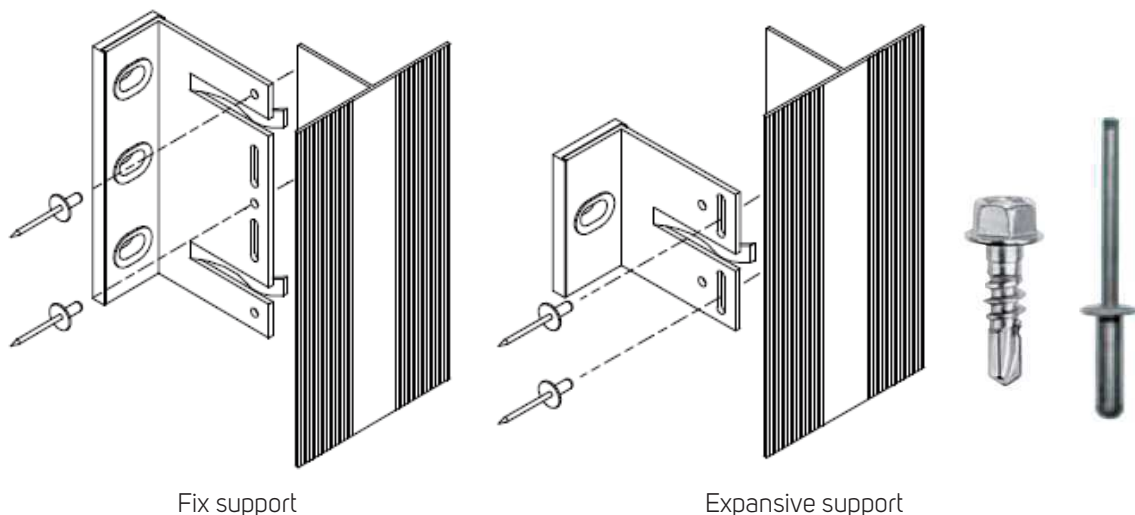

Fix support

Expansive support

Figure 2.1.7 - Fixing the aluminium profiles to the support brackets

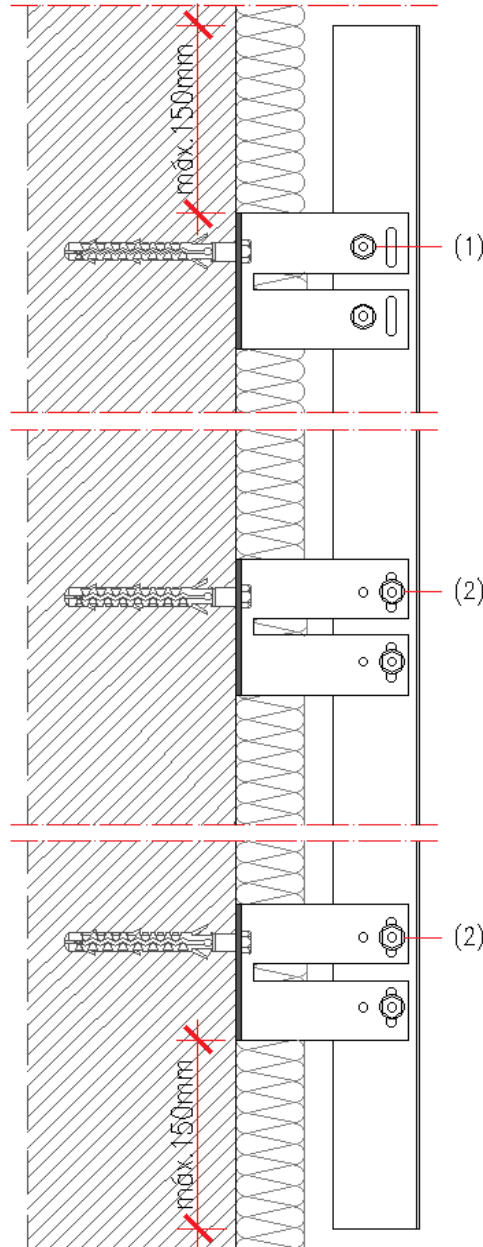

(1) Fix support; (2) Expansive support

Figure 2.1.8 - Fixing the aluminium profiles to the support brackets

Due to the high coefficient of thermal transmission, the support brackets can be insulated from the supporting wall with bases for thermal cutting (see figure 2.1.9).

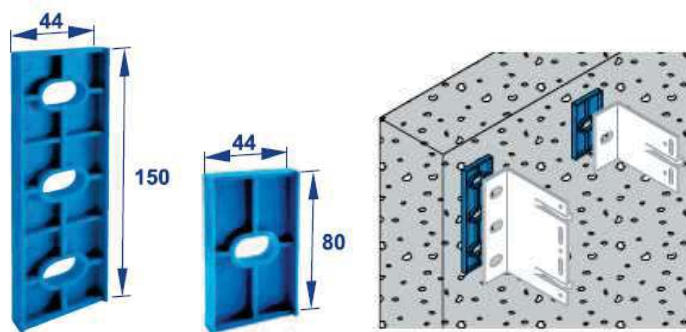

Figure 2.1.9 - Thermal cutting device for support brackets

2.1.06 Anchors for fixing the support brackets

The supporting squares are fixed to the support wall using anchors which can be metal plug holes with a diameter of 8 mm or plastic plug holes with a diameter of 10 mm, with a metal screw with a diameter of 7 mm (see figures 2.1.10 and 2.1.11).

With regard to the mechanical strength and stability of the anchors, they must be designed and built in such a way that the loads to which they will be subjected during their useful life do not involve one of the following consequences:

- Total or partial breakdown of the structure;
- Deformations that reach unacceptable proportions;
- Damage to other parts of structures, equipment or installations following excessive deformation of the supporting structure;
- Damage of great proportionality to the cause that originated it.

The anchorages must withstand shear loads, tensile loads and a combination of both during the expected life of the structure, ensuring:

- Adequate resistance to failure (Ultimate Strength Limits);
- Adequate resistance to displacement (Serviceability Limit States).

Anchorages must have an ETA (European Technical Assessment) certification with CE marking or, alternatively, a DH (Document of Homologation) containing the characteristic strength values and the respective security coefficients.

For anchorages that do not have any type of ETA or DH certification, the resistance values must be proven through technical documents or load tests.



Figure 2.1.10 - Plastic anchor of Ø10 mm

Stainless steel or galvanised steel screw of Ø7 mm, minimum length: 75 mm



Figure 2.1.11 - M8 Metal anchor

Stainless or galvanised steel, minimum length: 80 mm

2.1.07 Bushings for fixing thermal insulation

The thermal insulation is dimensioned in accordance with the Regulation on the Thermal Behaviour Characteristics of Buildings - RCCTE (*RCCTE-Regulamento das Características do Comportamento Térmico dos Edifícios*).

It must be fixed to the support using plastic bushings or similar material, normally with a wide head and the appropriate length for the thickness of the insulation (see figure 2.1.12).



Figure 2.1.12 - Bushing for fixing thermal insulation to the support structure

2.1.08 Wooden upright protection strips

When the structure consists of wooden uprights which durability is of class 2 according to EN 335, they must be protected from rainwater with a protective strip over their entire height.

This strip must be waterproof and 10 mm wider than the uprights on each side.

The strips can be made of flexible PVC or EPDM (see figure 2.1.13).

Protection strips can also be used on metal profiles, as an option.



Figure 2.1.13 - Flexible PVC or EPDM protection strip

Mandatory installation of wooden uprights with a durability of class 2

2.1.09 Screws for fixing the panels to a wooden structure

The screws must be at least of class A2 stainless steel, with a body diameter of 4.8 mm and a head diameter of 16 mm. A neoprene washer can be fitted to control the clamping force (see figure 2.1.14).

Screws with a smaller head diameter can be used, as long as they are applied with a 16 mm diameter metal washer with neoprene. The screw pulling force (P_k) must be greater than 2.0 kN (\pm 200 Kgf) for a penetration depth of 22 mm into the wood.

SFS Intec, ETANCO and EJOT manufacture specific screws for façades and can supply them lacquered in the desired colour.

Screws from other manufacturers can be used as long as they have the same performance.

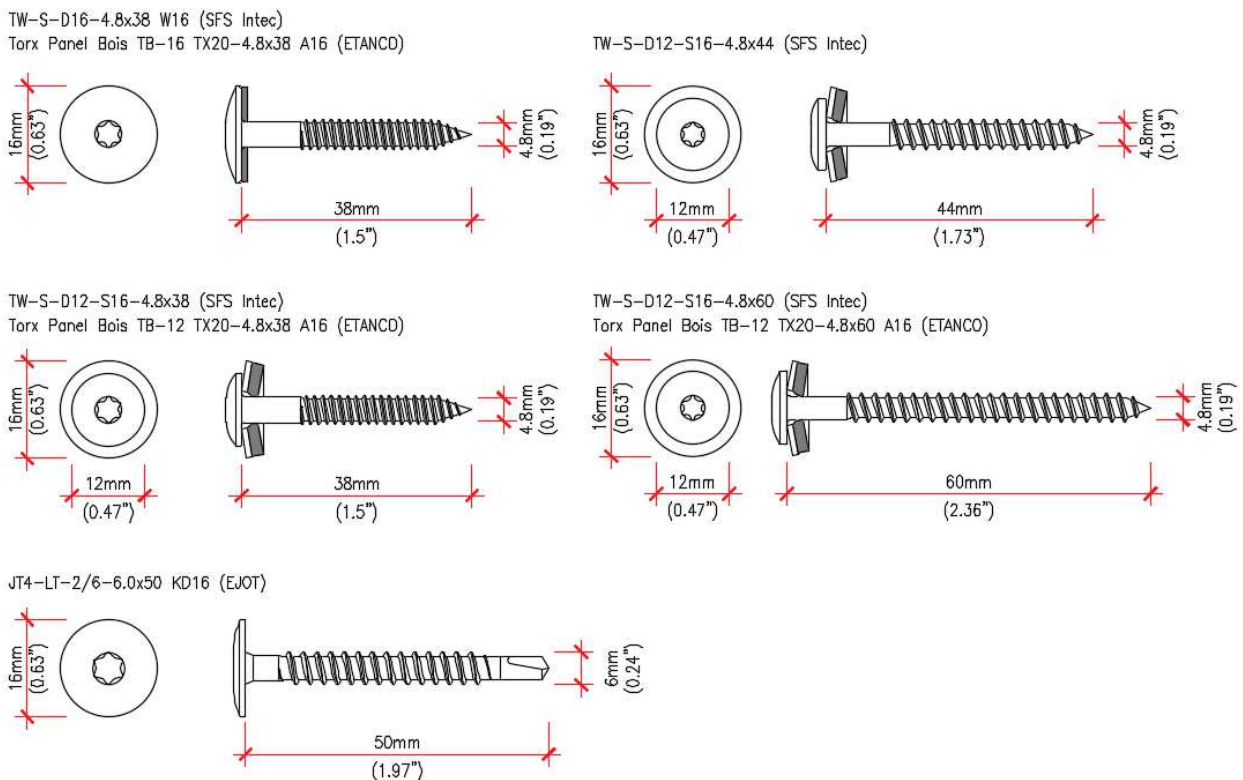

Figure 2.1.14 - Screws for wooden structure

2.1.10 Screws for fixing the panels supported on a galvanised steel structure

The screws for fixing the Viroc panels to the galvanised steel structure must be bimetallic, with a stainless steel body and a carbon steel drilling tip. The diameter of the head must be at least 16 mm and the body at least 5.5 mm. Screws with a smaller head diameter can be used as long as they are applied with a neoprene metal washer with a diameter of 16 mm. The length of the screw must be suitable for the connection between the thickness of the panel and that of the metal profile (see figure 2.1.15).

The pull-out force of the bolt (P_k) must be greater than 2.0 kN for any type of structure.

SFS Intec, ETANCO and EJOT manufacture specific screws for façade and can supply them lacquered in the desired colour.

Screws from other manufacturers can be used as long as they have the same performance.

2.1.11 Screws for fixing the panels supported on an aluminium structure

The screws for fixing the Viroc panels to the aluminium structure must be stainless steel or bimetallic. The diameter of the head must be at least 16 mm and the body at least 5.5 mm. Smaller head diameter screws can be used, provided they are applied with a 16 mm diameter neoprene metal washer. The length of the screw must be suitable for the connection between the thickness of the panel and that of the metal profile (see figure 2.1.15).

SFS Intec, ETANCO and EJOT manufacture specific screws for façades and can supply them lacquered in the desired colour. Screws from other manufacturers can be used as long as they have the same performance.

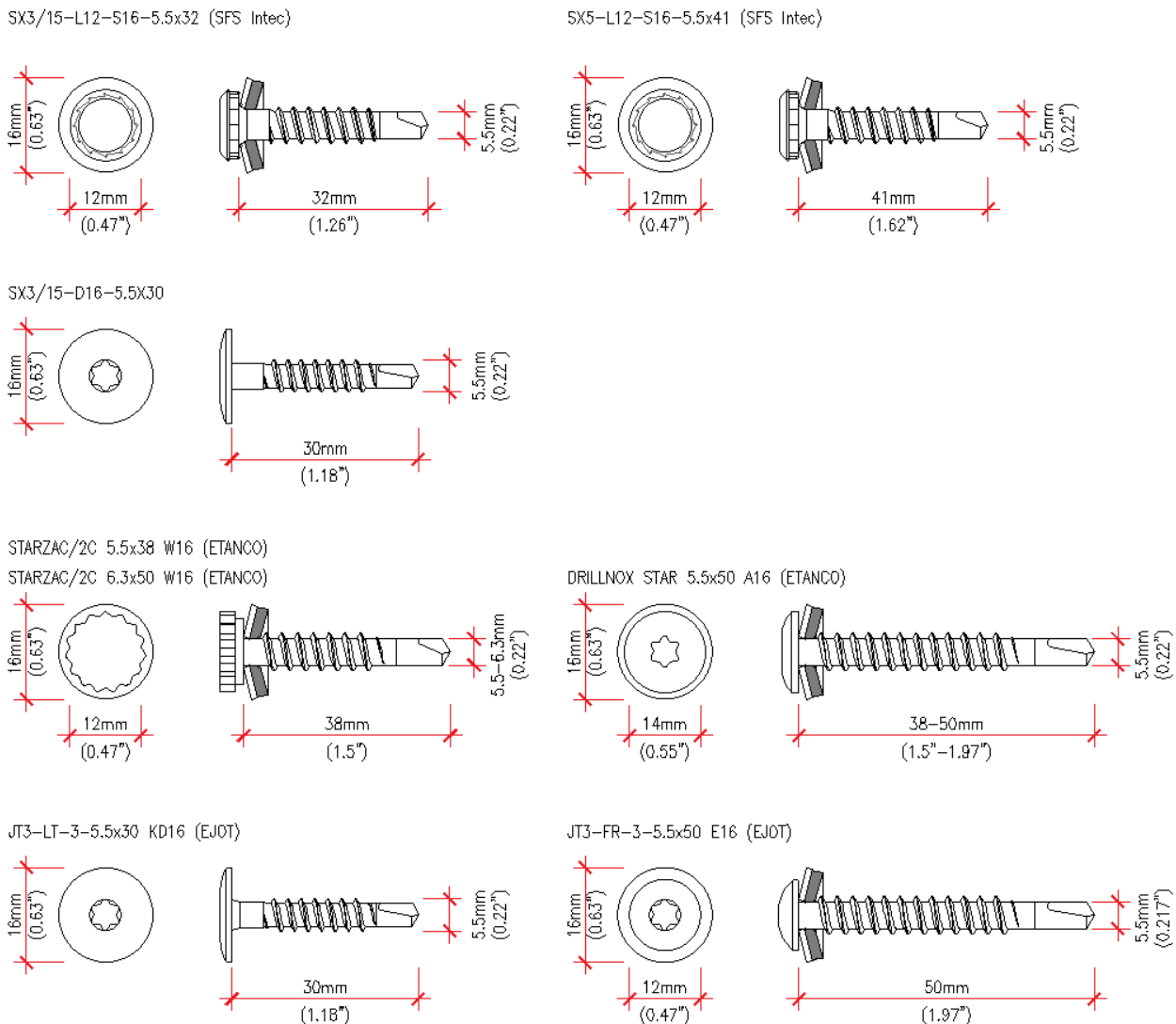

Figure 2.1.15 - Screws for metal structures

2.1.12 Rivets for fixing panels supported on a metal structure

When the support structure is made of galvanised steel or aluminium, rivets can be used to attach the Viroc panels. The rivets to be used must have an aluminium body and a stainless steel pulling mandrel. The diameter of the rivet body must be at least 4.8 mm and the length must be suitable for attaching the panel to the structure (see figure 2.1.16).

The rivet pull-out force (PK) must be greater than 2.0 kN for any type of structure (galvanised steel or aluminium).

When the panels are fixed with rivets, a tightening stop must be placed on the tip of the riveting tool, so as not to over-tighten and allow for normal shrinkage and expansion of the panel (see figure 2.1.17).

SFS Intec, ETANCO and EJOT manufacture specific rivets for façade and can supply them lacquered in the desired colour.

Rivets from other manufacturers can be used as long as they have the same performance.

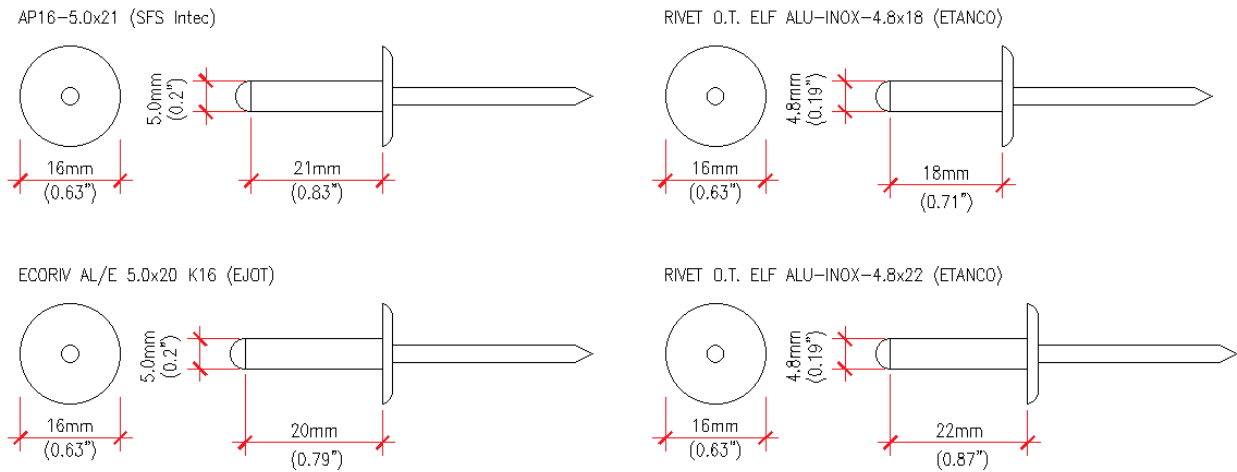

Figure 2.1.16 - Rivets for fixing Viroc panels to a metal structure

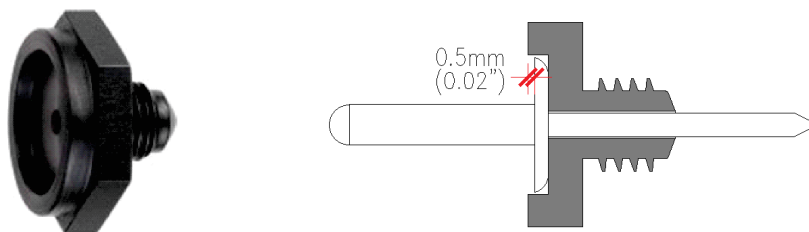

Figure 2.1.17 - Constricting nozzle, to be screwed into the riveting tool mouth

Mandatory use

2.1.13 Recommended thicknesses of the Viroc façade panels and their tolerance

Thickness: 12 mm \pm 1.0 mm; 16 mm \pm 1.2 mm

See the Viroc panel technical data file for the available thicknesses and colours.

2.1.14 Weight of panels

12 mm: 16.2 \pm 1.2 kg/m²;

16 mm: 21.6 \pm 1.6 kg/m².

2.1.15 Viroc panel manufacturing dimensions and cutting tolerances

Dimensions: 2600x1250 mm and 3000x1250 mm

Tolerances: Length and width: \pm 3 mm

Squarness: \leq 2 mm/m

Edge straightness: \leq 1.5 mm/m

See the Viroc panel technical data file for available dimensions and colours.

Any intermediate dimensions obtained by cutting the panels are possible.

2.1.16 Maximum format of panels applied to a façade

The largest size of panel to be applied to a ventilated façade depends on the type of structure to be used.

Wooden frame: 3000x1250 mm.

Galvanised steel or aluminium frame: 1500x1250 mm

2.1.17 Minimum format of panels applied to a façade

The smallest panel size to be applied to a ventilated façade is 300 mm.

Viroc Portugal does not recommend that the ratio between the length and width of the panel exceeds 3 ($L/B \leq 3$).

A panel that is too long and narrow tends to break easily.

2.1.18 Façade Assembly operations

The installation of a façade is carried out as follows:

- a. Marking and identification of the façade elements;
- b. Mounting the support brackets;
- c. Installation of thermal insulation;
- d. Assembly of the support profiles/mounts;
- e. Varnishing of the Viroc panels on both sides and tops;
- f. Fixing the panels;
- g. Treatment of singular points.

2.1.19 Marking and identification of the façade elements

There is no preferred assembly orientation. The system allows the assembly of all sizes and formats of intermediate dimensions. Viroc panels can be placed horizontally or vertically.

The aim is to follow the stereotomy defined by the architectural project.

2.1.20 Mounting the support brackets

The location of these elements determines the final position of the support profiles, so they must be positioned precisely.

2.1.21 Fixing the squares to the supporting wall

The support brackets are fixed to the support wall using anchors, which can be metal plugs with a diameter of 8 mm or plastic plugs with a diameter of 10 mm, with a metal screw with a diameter of 7 mm.

2.1.22 Angle plates

There are angle plates that make it easier to make corner angles. Its use is optional (see figure 2.1.18).

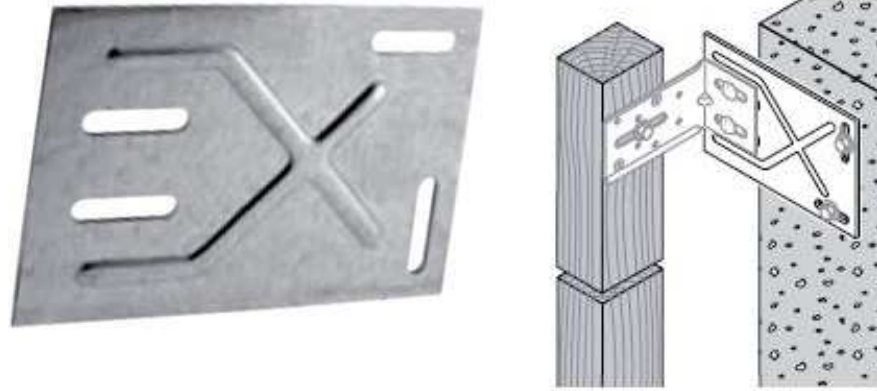

Figure 2.1.18 - Auxiliary angle plate, galvanised steel Z350. Thickness: 2.5 mm

2.1.23 Fitting the thermal insulation

The thermal insulation is dimensioned in accordance with the thermal conditioning rules of the RCCTE - Regulation on the Thermal Behaviour Characteristics of Buildings (*RCCTE-Regulamento das Características do Comportamento Térmico dos Edifícios*).

It is fixed to the support using plastic bushings or similar material, normally with a wide head and the appropriate length for the thickness of the insulation.

2.1.24 Mounting the support profiles

The support profiles are arranged vertically in accordance with the specifications and technical drawings presented in this document, duly adapted to the stereotomy of the architectural project.

The profiles can be arranged horizontally as long as there is room for air ventilation and the profiles do not accumulate water that could degrade them.

The distance between profiles/mounts must be such as to respect the distance between the panel fixings, the alignment of the uprights between adjacent elements must be checked and must not differ by more than 2 mm.

2.1.25 Fixing the profiles to the support brackets

Fixing the wooden uprights to the support brackets

The wooden uprights are connected to the support brackets using a $\varnothing \geq 6.0$ mm screw placed in the oval hole and a second $\varnothing \geq 3.5$ mm screw placed in one of the circular holes to block movement (see figure 2.1.19).

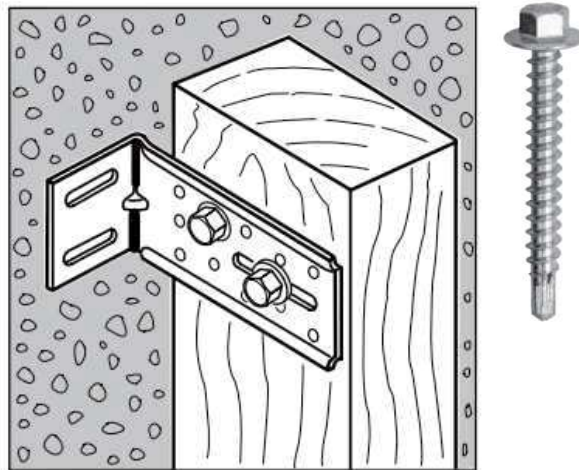

Figure 2.1.19 - Fixing the wooden uprights to the support brackets (2 screws of $\varnothing \geq 6$)

Fixing the galvanised steel profiles to the support brackets

The galvanised steel profiles are connected to the support brackets using self-drilling screws or rivets placed in the oval hole, and another screw placed in one of the circular holes to block movement. The connection can be made with self-drilling screws of $\varnothing \geq 5.5$ mm or rivets of $\varnothing \geq 4.8$ mm (see figure 2.1.20).

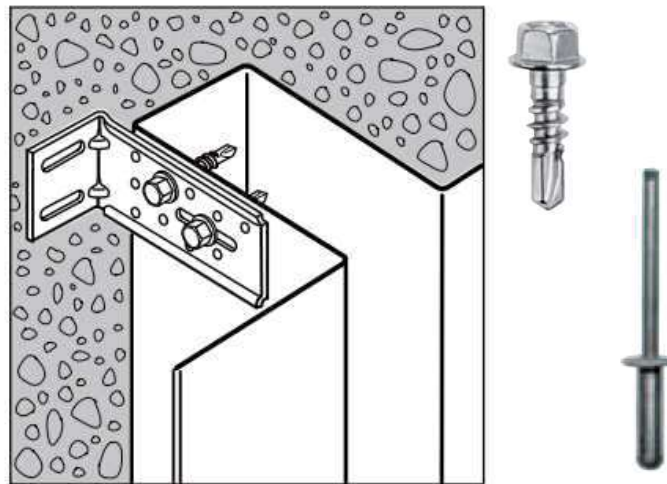

Figure 2.1.20 - Fixing the galvanised steel profiles to the support brackets (screws of $\varnothing \geq 5.5$ or rivets of $\varnothing \geq 4.8$)

Fixing the aluminium profiles to the support brackets

Due to the high expansion coefficient of aluminium profiles, the structure must be designed in such a way as to allow the upright profiles to expand.

The fixed connections are made with 2 screws/rivets placed in the circular bolt holes, blocking movement, located at the top of the profiles.

The expandable connections are made using 2 screws/rivets placed in the vertically oval shaped bolt holes. The connection can be made with $\varnothing \geq 5.5$ mm stainless steel self-drilling screws or with $\varnothing \geq 4.8$ mm rivets (see figure 2.1.21).



Figure 2.1.21 - Fixing the aluminium profiles to the support brackets

2.1.26 Protection strips of the wooden uprights

Whenever the structure durability is made of class 2 wood (EN 335), it must be protected from rainwater with a flexible PVC or EPDM band over its entire height.

Protection strips can also be used on metal profiles, as an option.

2.1.27 Cutting Viroc panels

Cuts to be made in Viroc panels should be made using a portable circular saw with suitable cutting blades. The cutting edges of the disk must be made of hard metal, usually tungsten carbide inserts (see figure 2.1.22).

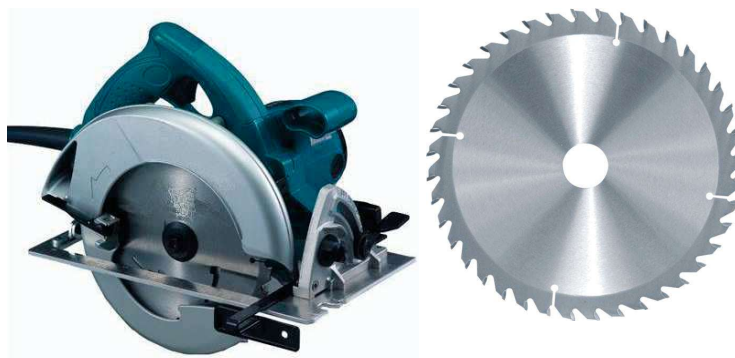

Figure 2.1.22 - Circular saw with tungsten cutting disc

2.1.28 Drilling Viroc panels

If bolt holes need to be drilled in the Viroc panels, they must be drilled with HSS metal drills and the drill must be in drilling mode, without impact (see figure 2.1.23).



Figure 2.1.23 - HSS drill and bits (for drilling metal)

2.1.29 Surface preparation of Viroc panels

Viroc panels are supplied raw, unfinished. The surfaces show some irregularities and imperfections, such as small incrustations, stains, scratches, small wood chips and salts from chemical reactions.

Before a finishing varnish is applied, the surfaces must be completely clean and dry, with no grease, dust or surface salts. Any visible surfaces should be cleaned/polished using an abrasive cleaning disc or, alternatively, the surface should be sanded with fine 120 grit sandpaper or higher.

Cleaning/polishing does not alter the natural appearance of the panel; it maintains the stains and heterogeneities that characterise it, as well as some salts and incrustations that are embedded in the surface.

The link below shows a video screening how Viroc panels are polished.

<https://www.youtube.com/watch?v=HeQZNVNOZYI>

2.1.30 Varnishing or painting Viroc panels

When used on ventilated façade, Viroc panels must be varnished. Exceptionally, they can be applied without varnish or paint, if they are installed under the conditions detailed in Chapter 2.3.

The purpose of applying varnish to the Viroc panel is to protect it from the aggressions of the environment in which it is located, due to exposure to sunlight and the elements, increasing its durability, making it easier to clean and maintaining its appearance over time. Applying a varnish changes the tone of the Viroc panel natural colour, giving it a "wet" appearance with some shine. After drying, the wet look is softened.

There are no specific paints or varnishes to be applied to Viroc. The panel has a surface alkalinity (PH) of 11 to 13, so paints and varnishes suitable for concrete and wood surfaces at the same time are usually the best when applied to Viroc panel. Paints and varnishes made from acrylic resins or aliphatic polyurethane resins are suitable as they do not turn yellow on exposure to UV rays. Solvent-based varnishes are the ones that have shown the best performance, but water-based varnishes are the ones that least alter the original colour of the panel.

Generally speaking, varnishes are easy to apply, but it is very important to bear in mind that the application must be continuous and constant, to guarantee the homogeneity of the finish on the panel and so that the surface doesn't become stained and have different shades. Panels must always be painted/varnished on both sides and tops. The application procedures provided by the respective manufacturers must always be followed for the recommended coats.

When paints and varnishes are applied on site, they should be applied in a dry, clean place away from the sunlight.

2.1.31 Fixing Viroc panels

The Viroc panels that constitute the façade are fixed to a structure using screws.

The panels, when placed outdoors, are subject to dimensional variations in the order of +1.0 mm to -3.0 mm per linear metre when the panel is sealed on both sides and tops.

In order to allow for dimensional variations of the panels without introducing stresses that could damage the panels, the fixing system must allow for dimensional variation with this in mind.

For the panel peripheral fixings, the diameter of the bolt holes to be drilled in the panels to install the screws should be 10 mm larger than that of the body of the screw, to allow for shrinkage and expansion without introducing stress.

When fixing the central area of the panel, the diameter of the bolt holes must be the same as that of the body of the screw, fixing the panel rigidly. Your task is to ensure proper positioning.

The panel is fixed from the Fix supports in order to position the panel. The expansion supports will only be built later, in order to avoid introducing stresses as the panels sag.

The screws should be placed at a distance of 50 to 75 mm from the edges of the panels. The maximum distance between screws is 600 mm both horizontally and vertically.

Video of the installation of a Viroc façade, fixed with screws.

<https://www.youtube.com/watch?v=PbhJI-ta5rA&t=56s>

Wooden structure

The panels must be glued and screwed together as shown in figure 2.1.24.

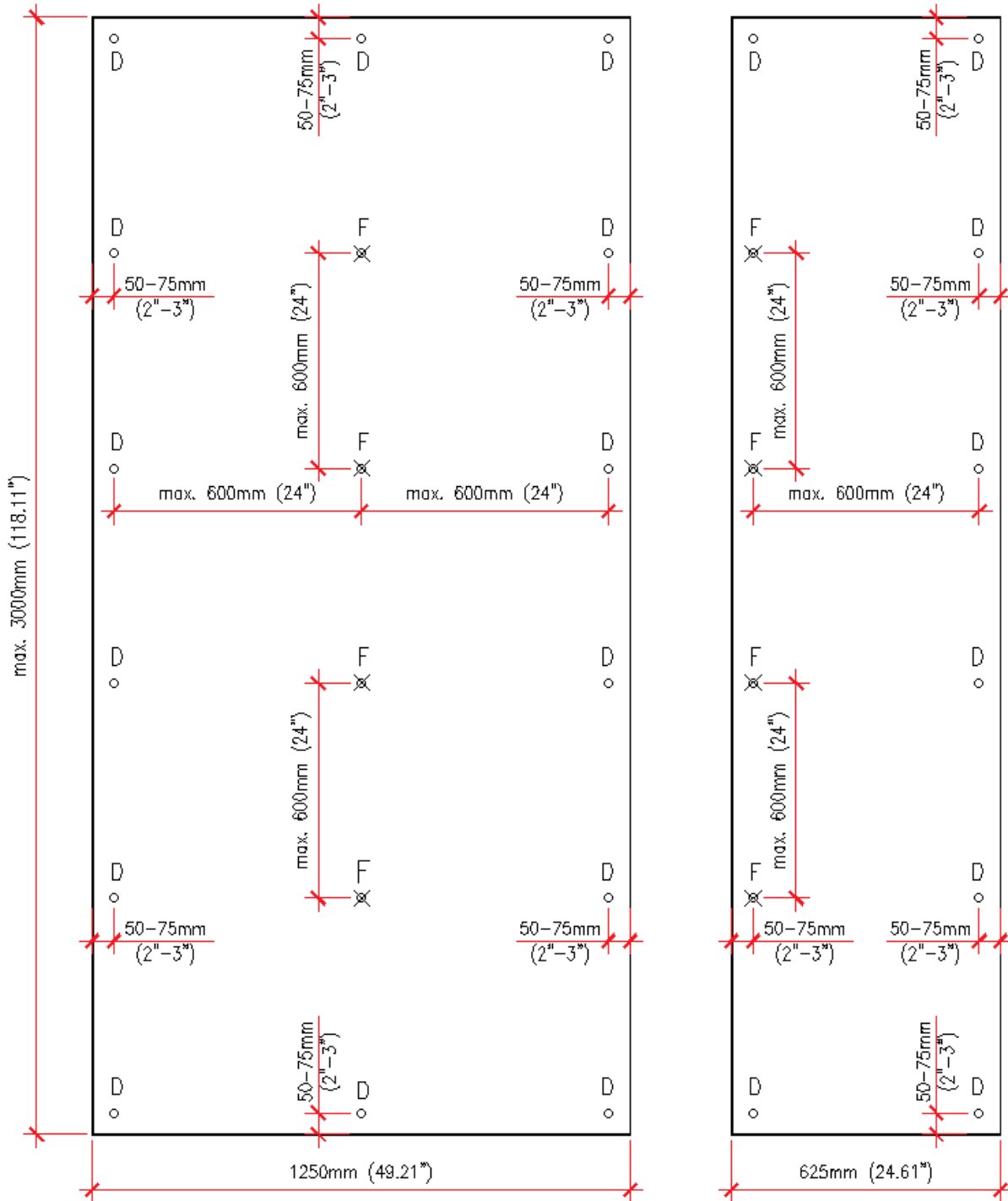



-  D - Expansion support, hole in the panel with a diameter of \varnothing 10 mm, to allow the panels to expand and contract
-  F - Fix support, hole in the panel with a diameter of \varnothing 5 mm, to rigidly fix the movements

Figure 2.1.24 - Location of fixings and hole diameter

The positioning of the screws for fixing the façade panels must be perpendicular to the plane, with a maximum error of 2.5° and with a correct tightening, without crushing the neoprene washer (see figure 2.1.25) and must not be less than 15 mm from the edge of the wooden beam (see figure 2.1.26).

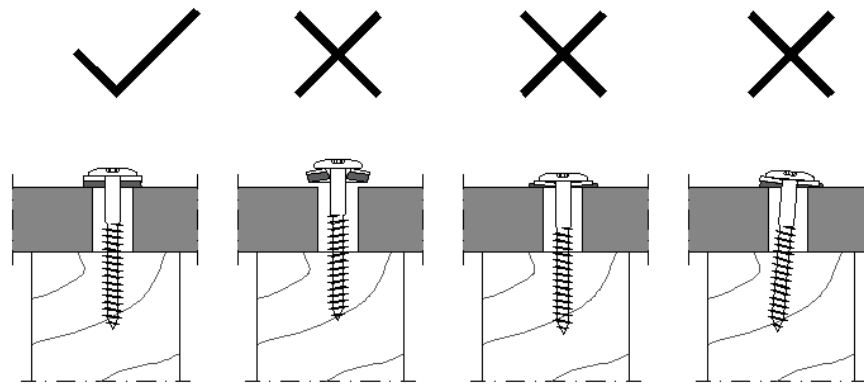

Figure 2.1.25 - Correct tightening and positioning of the screws

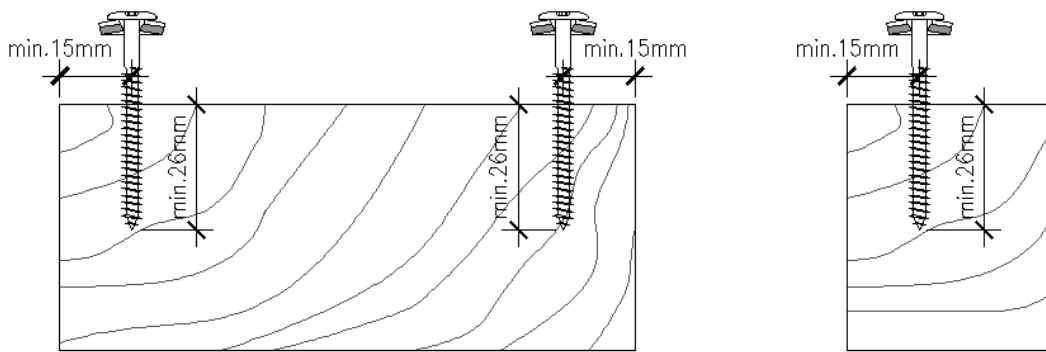
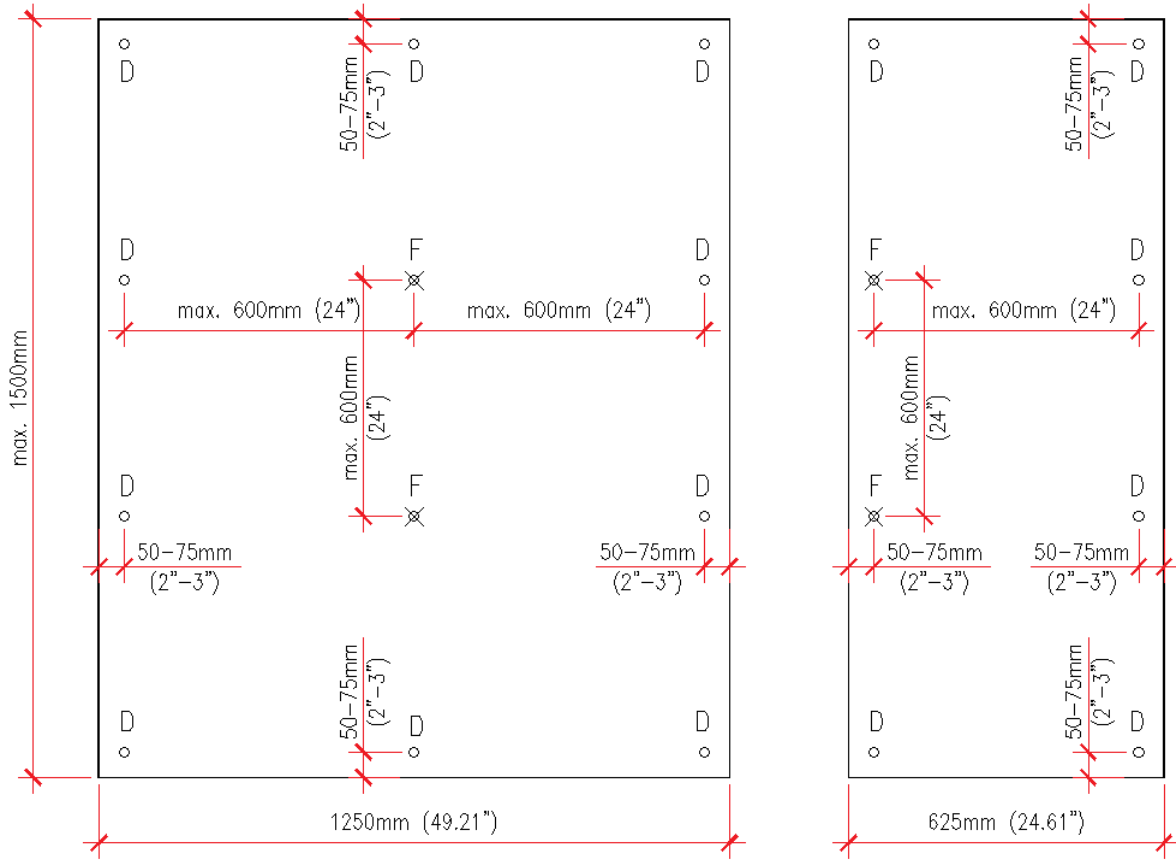

Figure 2.1.26 - Minimum distance from the screws to the edges of the beams

Galvanised steel and aluminium frame

The panels must be glued and screwed together according to figure 2.1.27

Please note that the maximum size allowed is 1500x1250 mm.



- D - Expansion support, hole in the panel with a diameter of \varnothing 10 mm, to allow the panels to expand and contract
- ⊗ F - Fix support, hole in the panel with a diameter of \varnothing 5.5 mm, to rigidly fix the movements

Figure 2.1.27 - Maximum panel size and location of fixings

The positioning of the screws for fixing the façade panels must be perpendicular to the plane, with a maximum error of 2.5° and with a correct tightening, without crushing the neoprene washer (see figure 2.1.28) and must not be less than 10 mm from the edge of the profile (see figure 2.1.29).

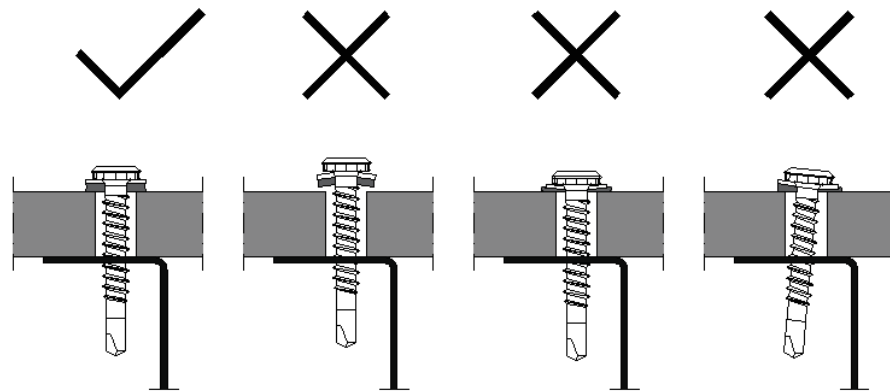

Figure 2.1.28 - Correct tightening and positioning of the screws

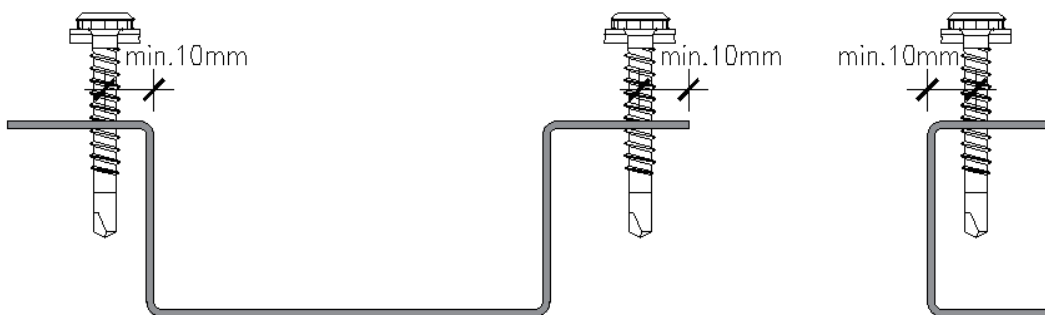

Figure 2.1.29 - Correct positioning of screws or rivets
(minimum distance from edge of profile 10 mm)

2.1.32 Auxiliary assembly tools

There are various auxiliary tools that can be used to facilitate assembly work, such as spanners for centering bolt holes and screws (see figures 2.1.30, 2.1.31 and 2.1.32).



Figure 2.1.30 - Spanners for centering screws



Figure 2.1.31 - spanners for bolt holes-centering



Figure 2.1.32 - Tool for bolt holes-centering

2.1.33 Treatment of the joints

Viroc panels are installed so that the joints between panels, both vertical and horizontal, have an opening of between 5 and 8 mm. The joints can remain open or closed with a profile for aesthetic reasons.

2.1.34 Air foil ventilation

The ventilated façade, as recommended in this Technical File, forms a continuous sheet of air between the back of the panel and the thermal insulation.

The minimum opening for ventilation of the air foil is 20 mm thick. This distance must be respected even in areas where there may be obstructions.

At the base of the façade, the opening must be protected by a grille or perforated plate to prevent birds or rodents from entering (see figure 2.1.33).



Figure 2.1.33 - Perforated anti-rodent profile

The opening at the top of the façade is protected by a ruffle to prevent water from entering directly into the air gap.

The air gap must be compartmentalised, both vertically and horizontally, without impeding the free circulation of air.

The purpose of this compartmentalisation is to prevent fire from spreading between different floors or elevations in the event of a fire.

The air gap can be compartmentalised using galvanised steel sheet or aluminium, see general details.

2.1.35 Angle profiles

Some manufacturers of accessory elements for façades have auxiliary profiles for finishing the corners of the façade. The use of these profiles is optional (see figures 2.1.34 and 2.1.35).



Figure 2.1.34 - Corner angle profiles



Figure 2.1.35 - Corner angle profiles

2.1.36 Cleaning the panels after application

The panels can be cleaned throughout the lifespan of the project by spraying them with water and a neutral detergent.

2.1.37 Replacing a panel

To replace a façade panel, the existing panel must first be removed.

Before starting to install a new panel, it is necessary to check that the supporting structure is in a position to receive and support the new façade panel.

It is necessary to check that the structure is aligned and levelled with the rest of the façade, that the area where the new screws are to be placed is intact; otherwise it needs to be repaired.

2.1.38 Impact resistance

Hard Body Impact Energy EN 1128

12 mm, E = 12.9 Joules, Burst Energy

16 mm, E = 12.8 Joules, Burst Energy

Impact test according to ETAG 034

12 mm thick panel

Type of Impact	Energy	Results
Hard Body	1 J	No damage (Pass)
	3 J	No damage (Pass)
Soft Body	20 J	No damage (Pass)
	60 J	No damage (Pass)
	100 J	No damage (Pass)
	130 J	No damage (Pass)
	300 J	Fail

2.1.39 Wind action

Exposure to wind action perpendicular to the plane of the panel corresponds to a pressure or depression (in kN/m^2), whose design resistance value is given in Tables 1, 2 and 3.

2.1.40 Wind safety check

Wind loads are quantified in accordance with the National Annex of Eurocode 1 (RSA).

The wind resistance load tables were drawn up on the basis of experimental tests for the situation that most affects a panel resistance to wind loads: suction.

2.1.41 Example of Safety check of a Viroc panel to wind loads

For a 12 mm thick Viroc panel, with the configuration shown below, what is the maximum wind load the panel can withstand?

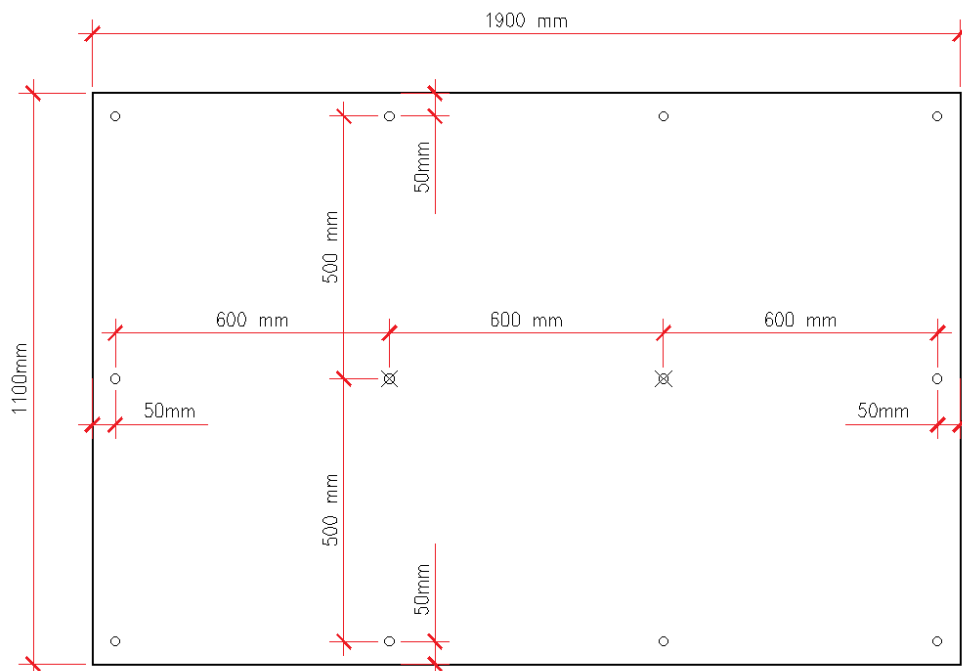

Number of screws horizontally: 4

Number of vertical screws: 3,

Configuration: 4x3, we use the Nx3 table

Horizontal distance between screws: 600 mm, => See Table 3

Vertical distance between screws: 500 mm

Horizontal distance between screws: 600 mm (24")											
Thickness of panel	(H x V)	Vertical distance between screws									
		300 mm kN/m ²	12" psf	400 mm kN/m ²	16" psf	500 mm kN/m ²	20" psf	600 mm kN/m ²	24" psf	700 mm kN/m ²	28" psf
12 mm 1/2"	2 x 2	1,4	29	1,4	29	1,4	29	1,2	25	1,0	21
	2 x 3	1,4	29	1,4	29	1,2	24	1,0	20	0,8	17
	2 x N	1,4	29	1,4	29	1,2	24	1,0	20	0,8	17
	3 x 2	1,7	36	1,4	28	1,1	24	1,0	20	0,9	18
	N x 2	1,7	36	1,4	28	1,1	24	1,0	20	0,9	18
	3 x 3	1,5	32	1,2	24	0,9	19	0,8	16	0,7	14
	3 x N	1,5	32	1,2	24	0,9	19	0,8	16	0,7	14
	N x 3	1,5	32	1,2	24	0,9	19	0,8	16	0,7	14
16 mm 5/8"	2 x 2	3,3	69	3,3	69	3,0	62	2,5	53	2,2	46
	2 x 3	3,3	69	3,1	64	2,5	52	2,1	43	1,8	37
	2 x N	3,3	69	3,1	64	2,5	52	2,1	43	1,8	37
	3 x 2	3,6	75	2,9	60	2,4	50	2,1	43	1,8	38
	N x 2	3,6	75	2,9	60	2,4	50	2,1	43	1,8	38
	3 x 3	1,7	35	1,3	27	1,0	21	0,8	18	0,7	15
	3 x N	1,7	35	1,3	27	1,0	21	0,8	18	0,7	15
	N x 3	1,7	35	1,3	27	1,0	21	0,8	18	0,7	15

Table 4 - Permissible pressure, distance of 600 mm between screws horizontally

The design resistance value of the Viroc panel to wind pressure (w_{Rd}) is 0.9 KN/m² (19 psf)

Note: The action of the wind exerts a pressure or depression on the panel. This is a constraint when it acts as a depression, since the panel is fixed only by the head of the screws and breakage occurs by cutting/punching the panel in these areas.

2.1.42 Details, wooden structure

Figures 2.1.36 to 2.1.50 show examples of various details and unique areas of the façade.

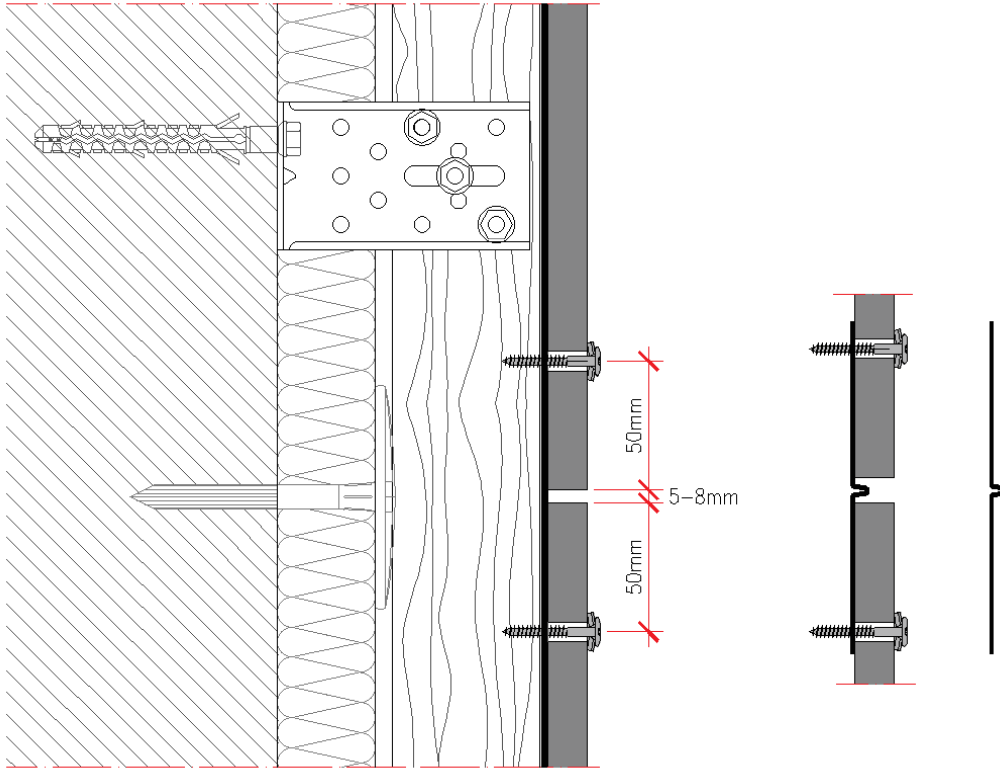

Figure 2.1.36 - Vertical section, joint between panels

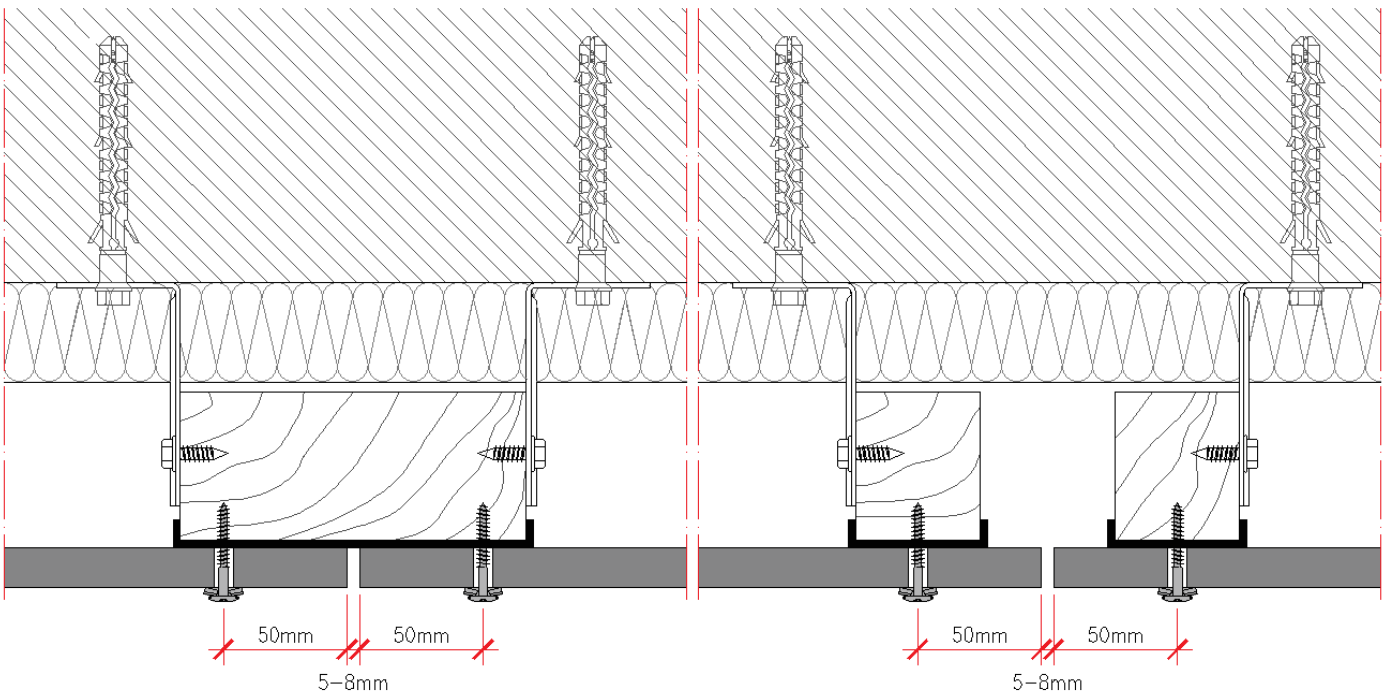

Figure 2.1.37 - Horizontal section, joint between panels

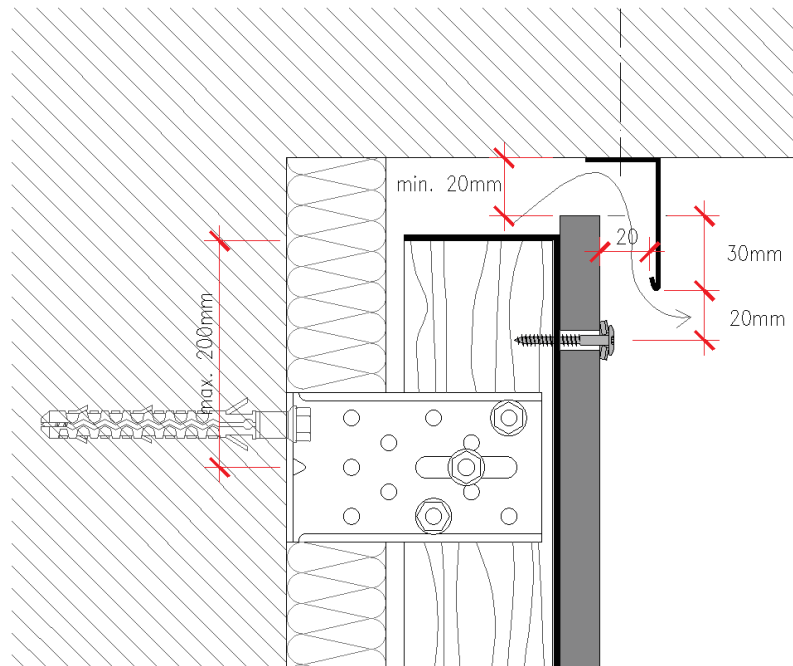

Figure 2.1.38 - Balcony finish

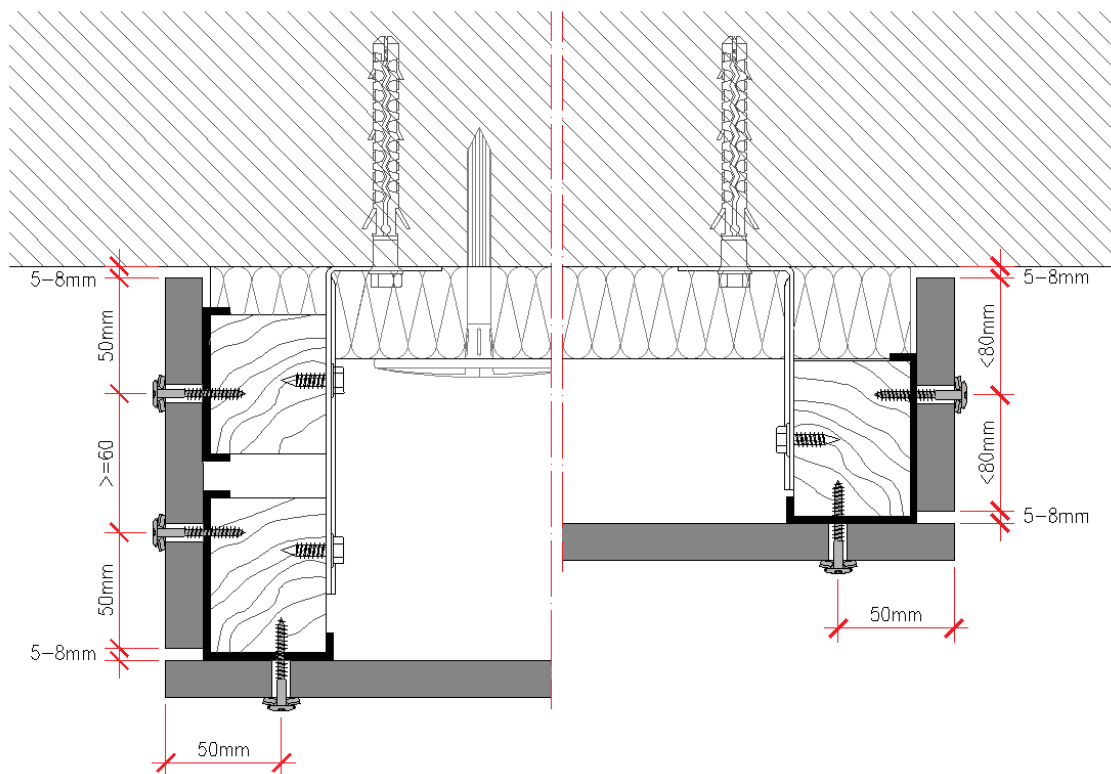

Figure 2.1.39 - Side finish

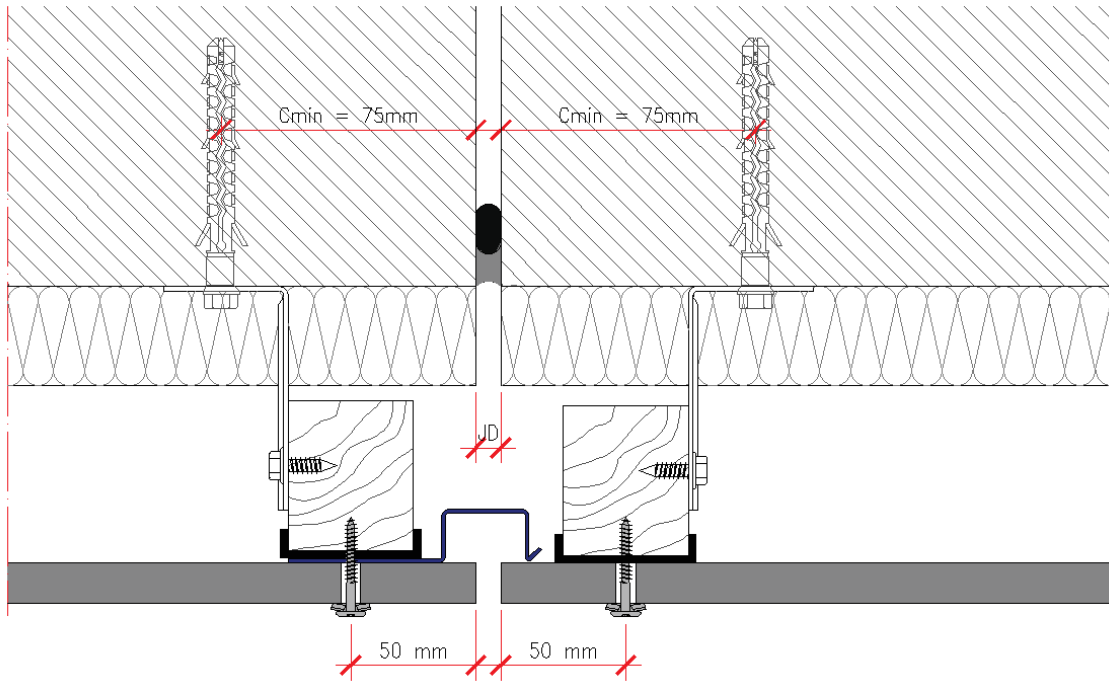

Figure 2.1.40 - Expansion joint

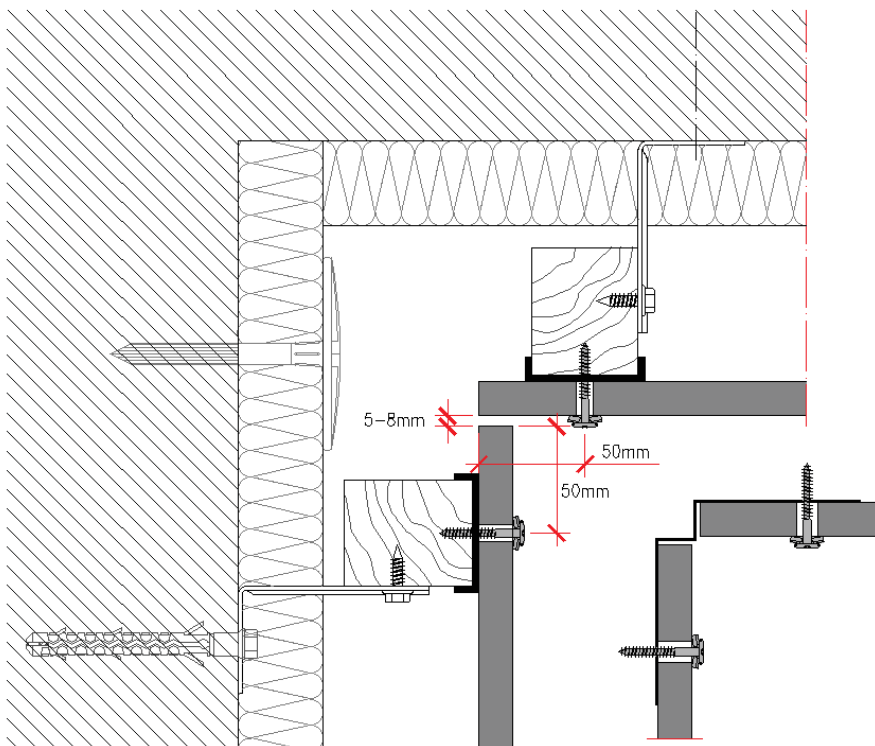
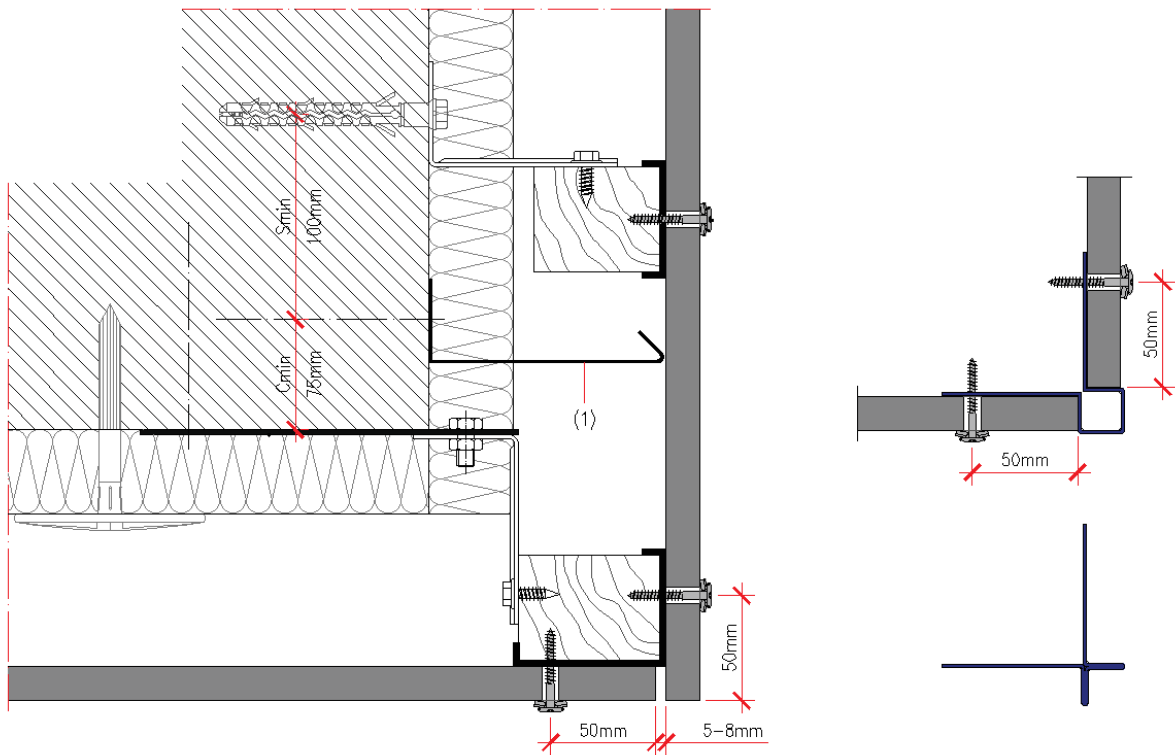

Figure 2.1.41 - Corner angle



(1) Compartmentalisation of the air foil

Figure 2.1.42 - Corner angle

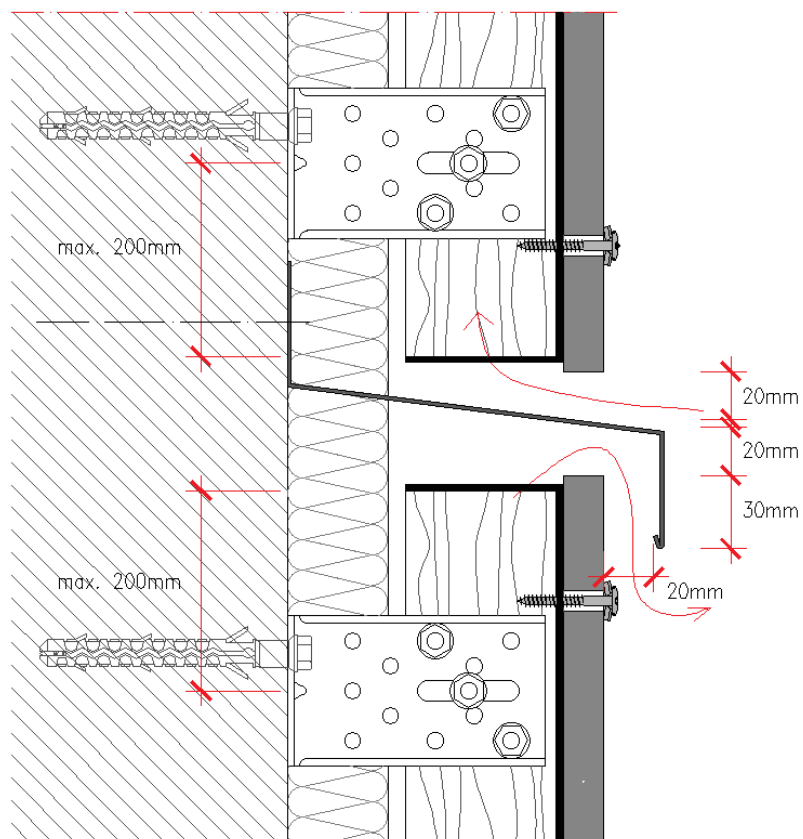

Figure 2.1.43 - Horizontal compartmentalisation of the air gap

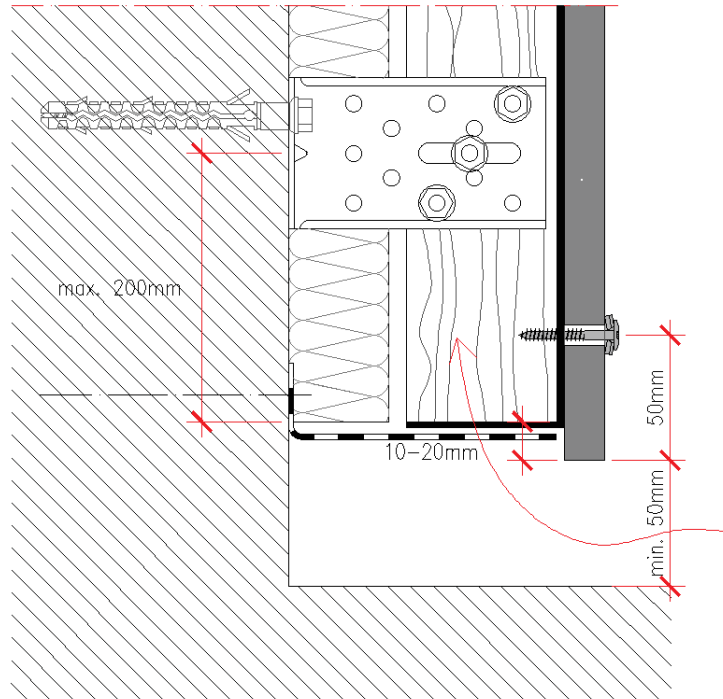

Figure 2.1.44 - Detail of the base, anti-rodent grid

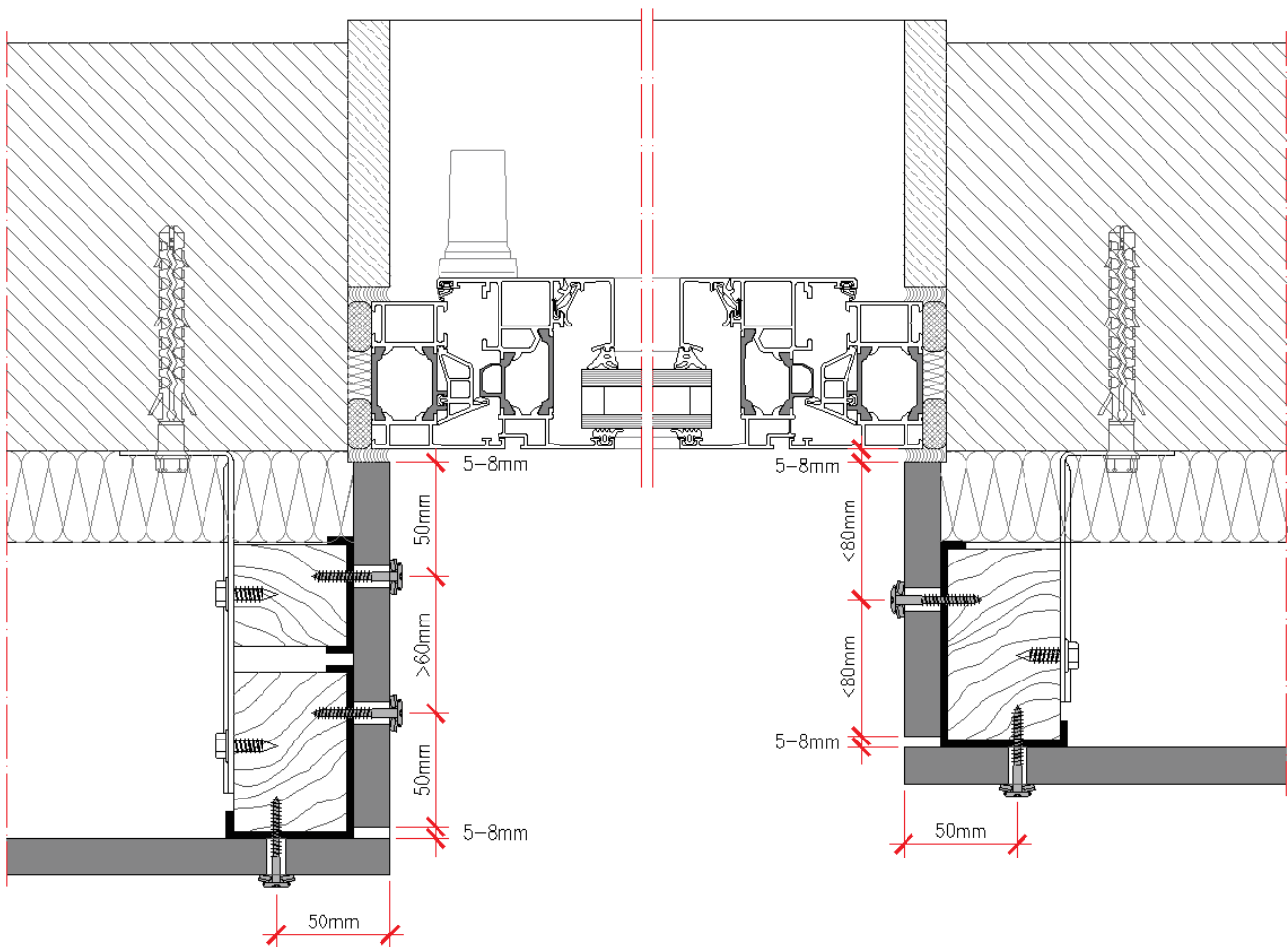

Figure 2.1.45 - Horizontal section, window opening

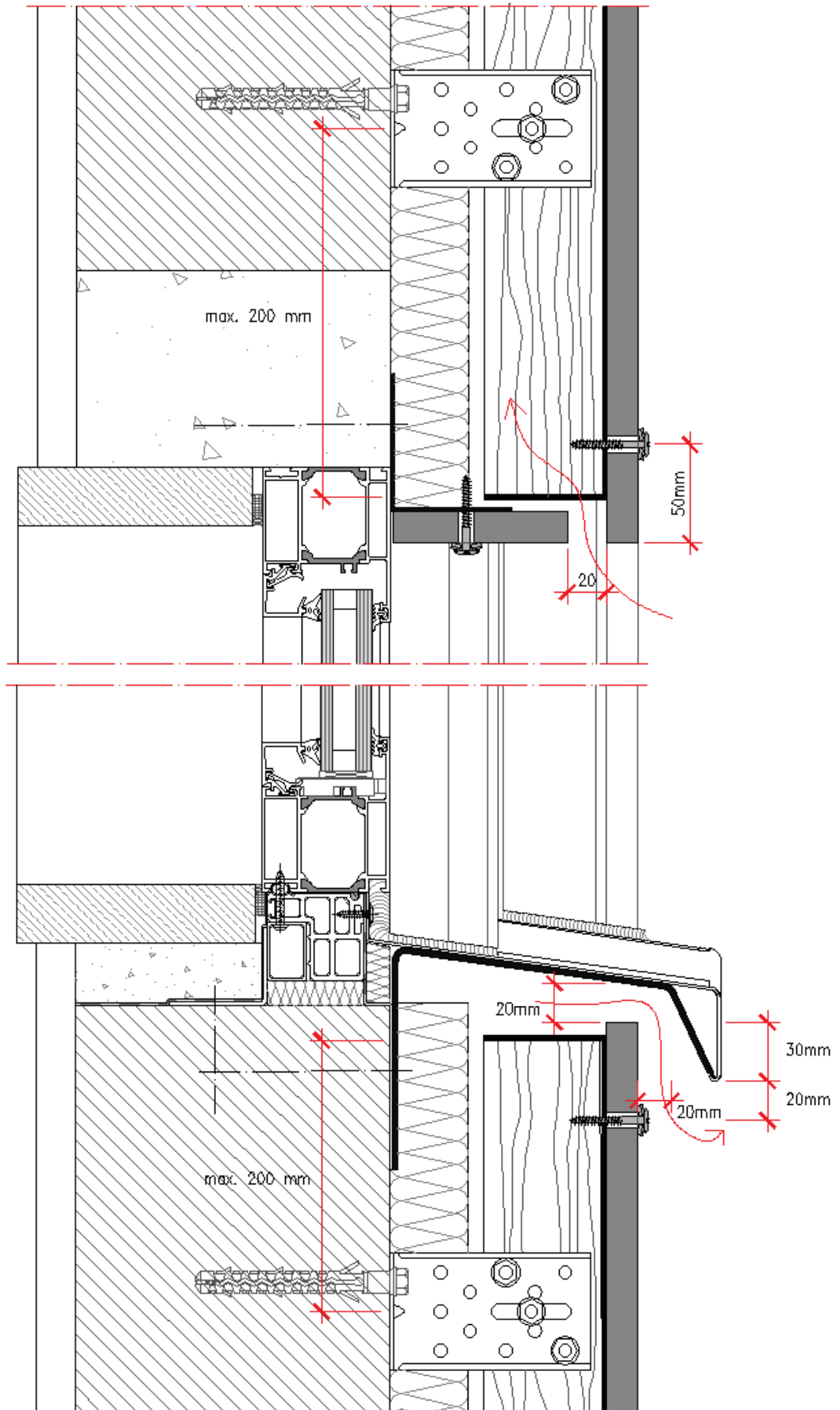

Figure 2.1.46 - Vertical section, window opening

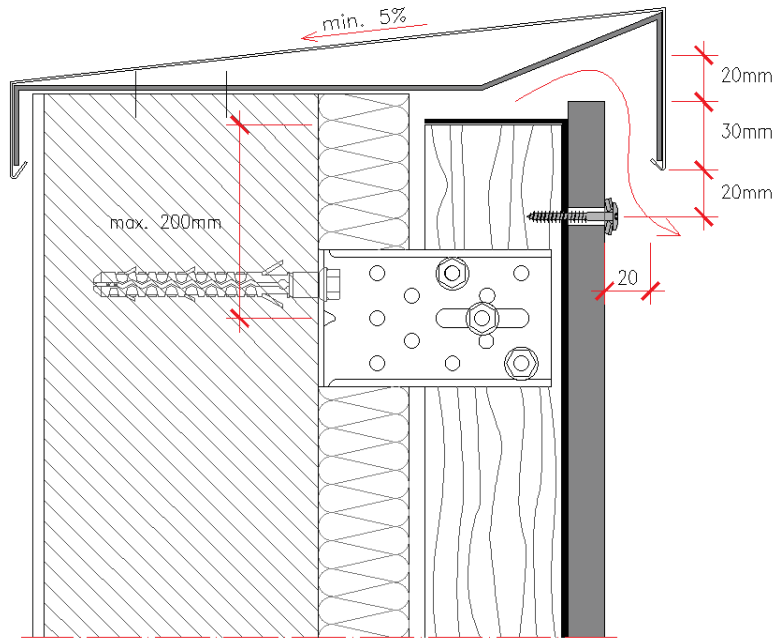

Figure 2.1.47 - Detail of the top

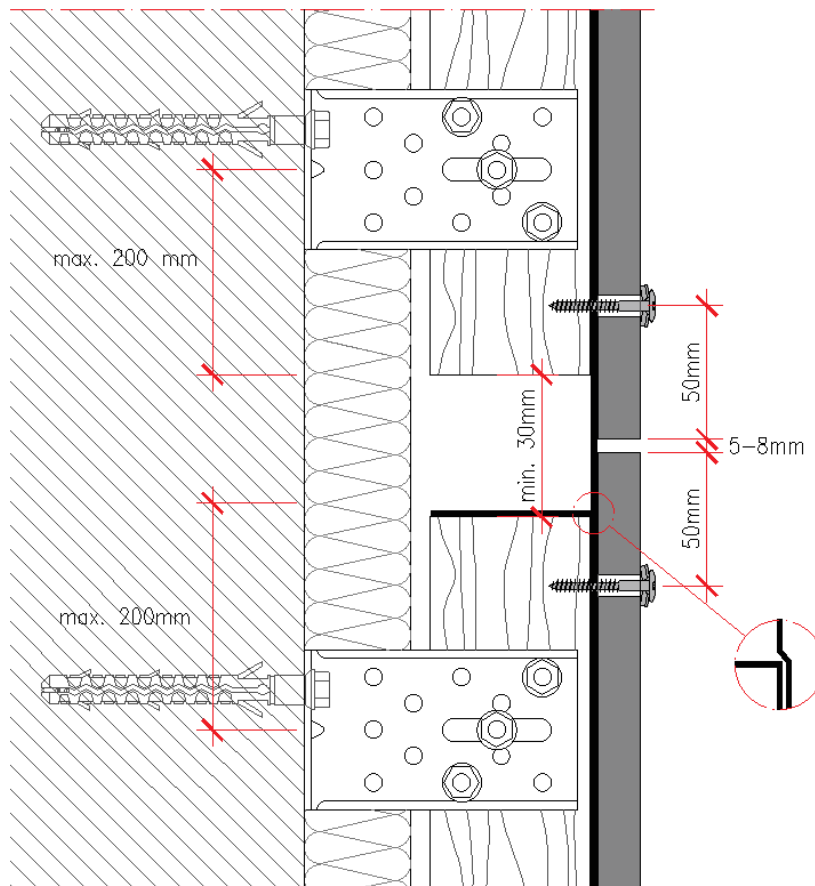

Figure 2.1.48 - Fractionation of the structure: Profiles length ≤ 6 m

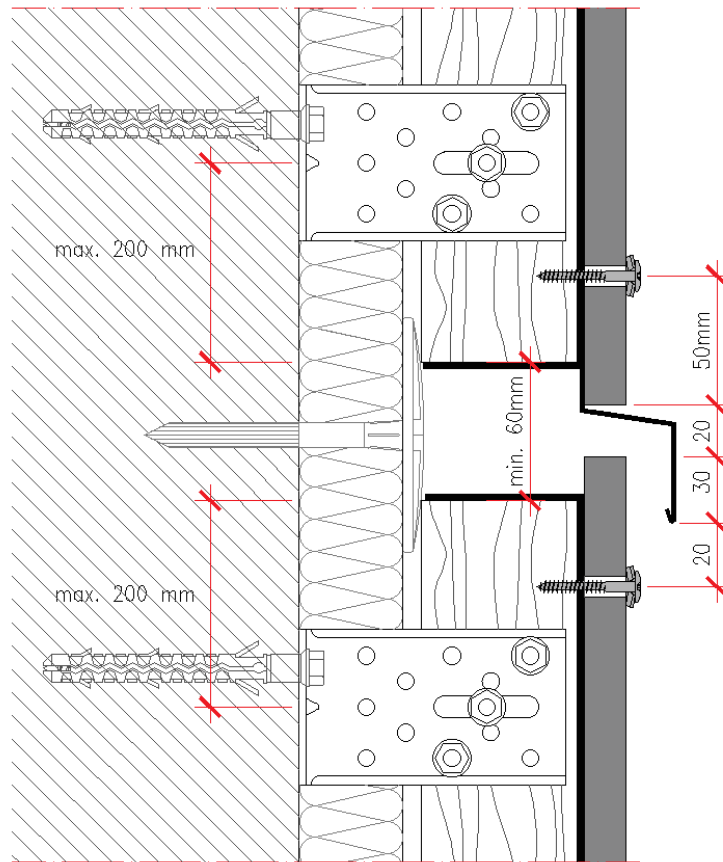
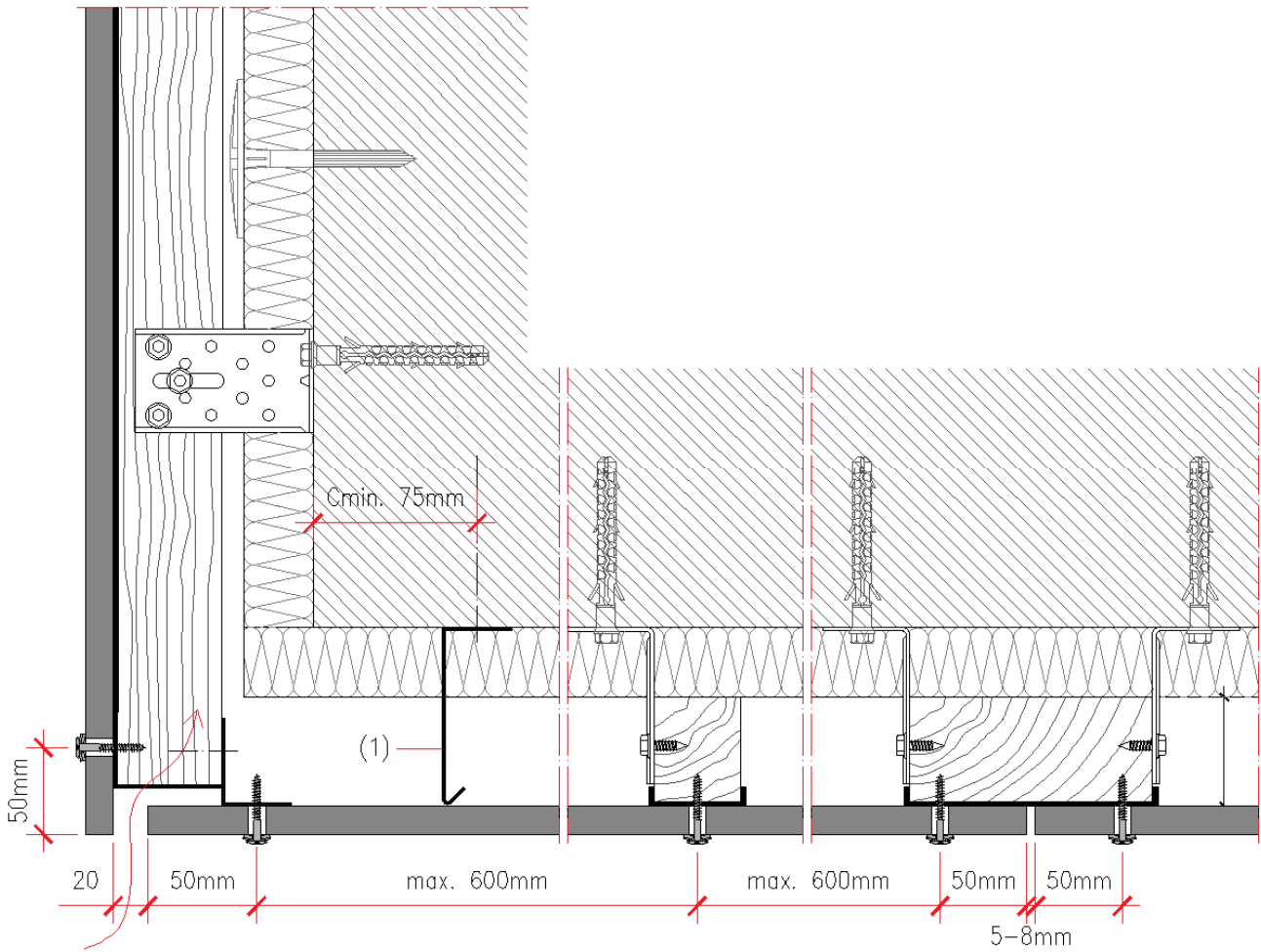

Figure 2.1.49 - Fractionation of the structure: Profiles length > 6 m



(1) Compartmentalisation of the air foil

(2)

Figure 2.1.50 - Detail of the façade - false ceiling connection

2.1.43 Details, galvanised steel frame

Figures 2.1.51 to 2.1.66 show examples of various details and unique areas of the façade.

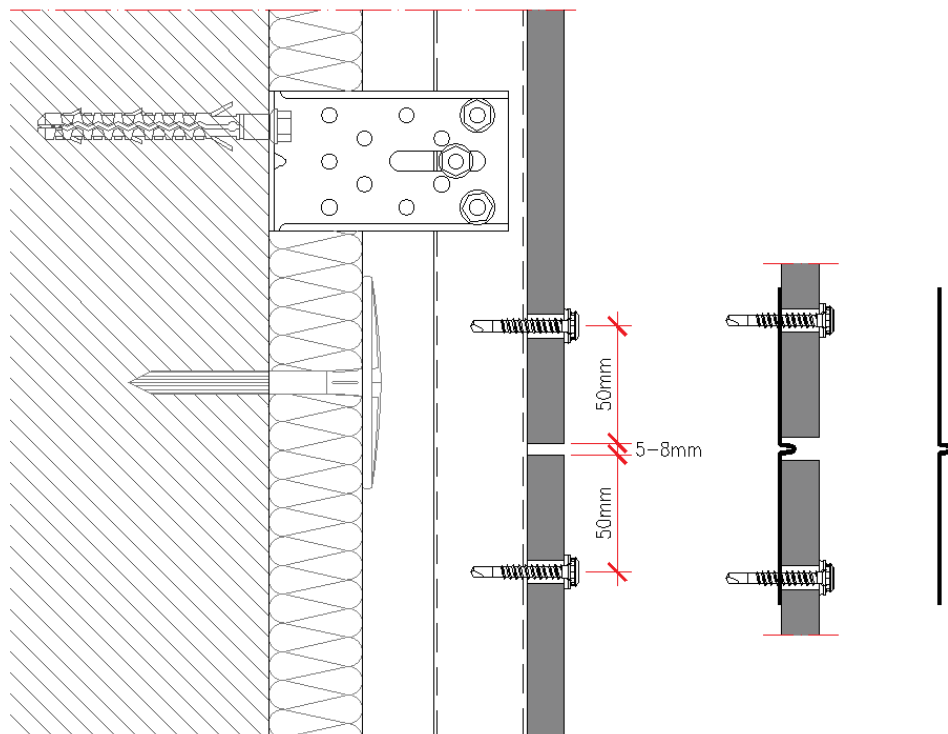

Figure 2.1.51 - Vertical section, joint between panels

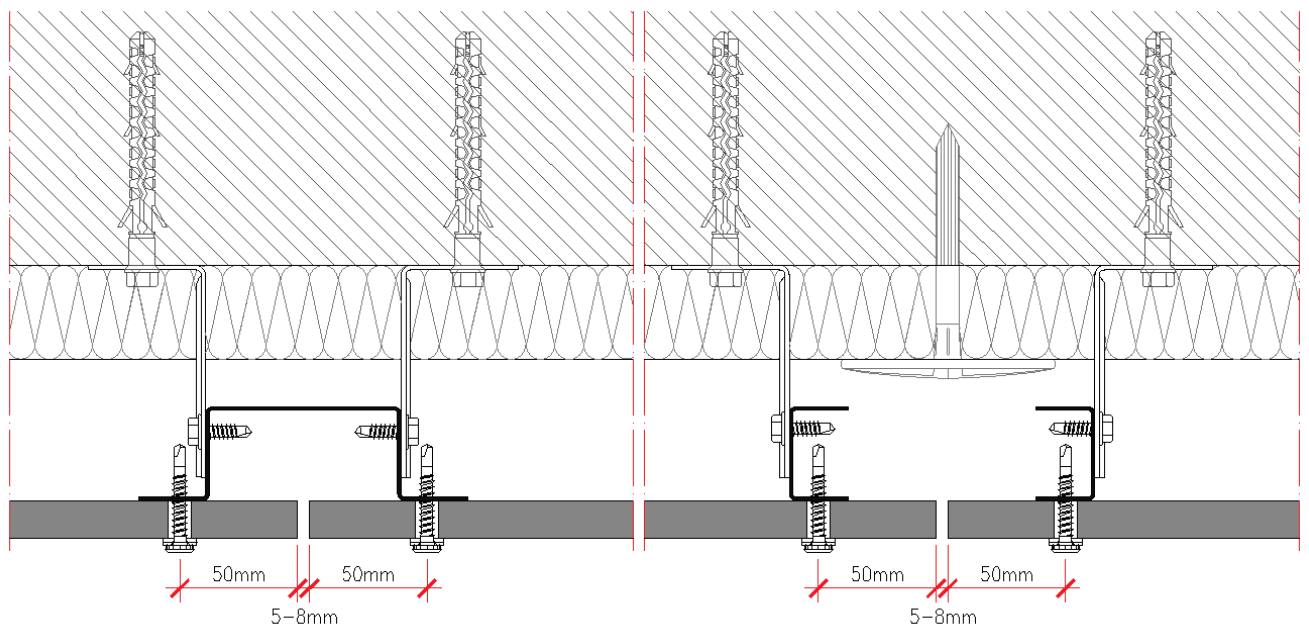

Figure 2.1.52 - Horizontal section, joint between panels

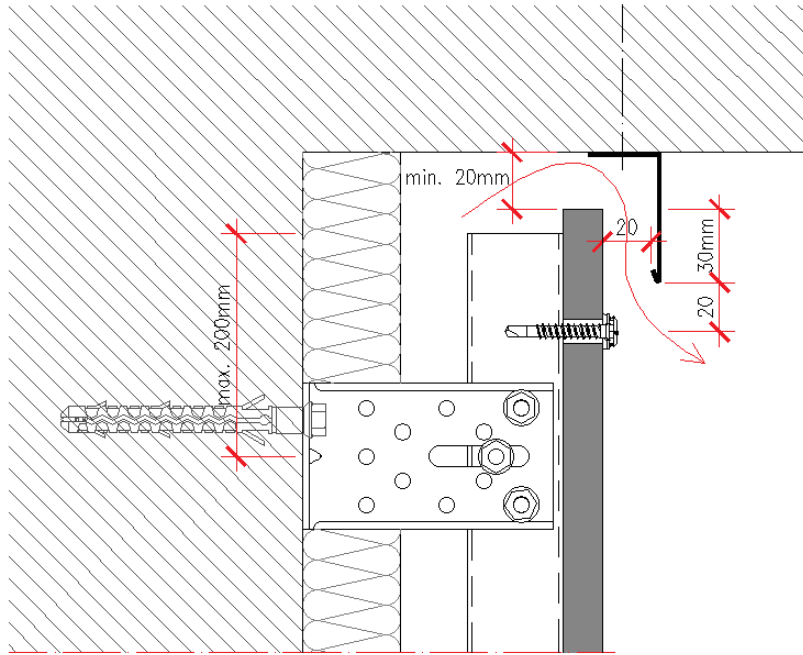

Figure 2.1.53 - Balcony finish

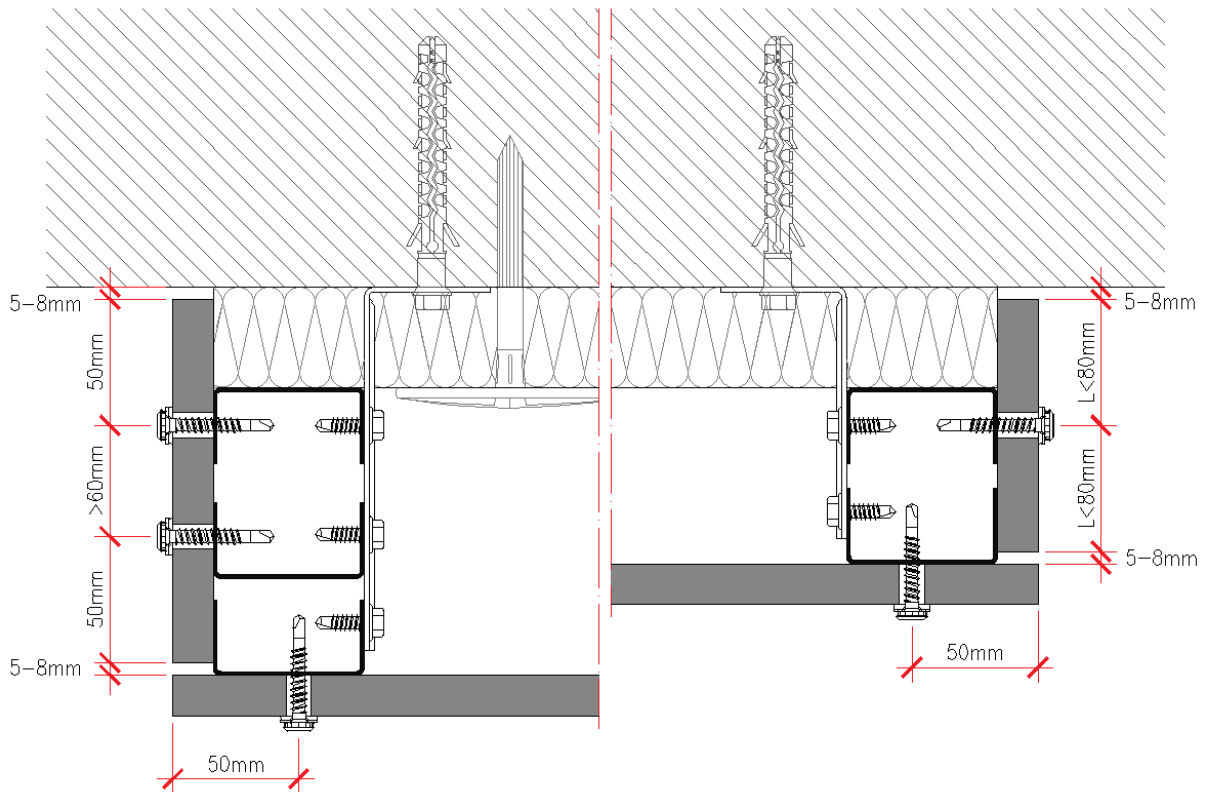

Figure 2.1.54 - Side finish

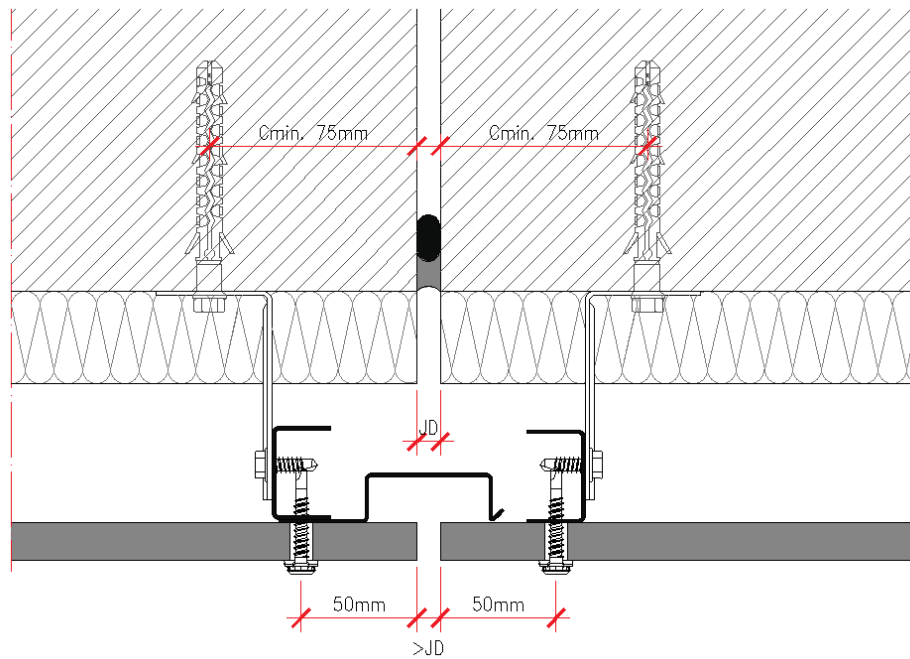

Figure 2.155 - Expansion joint

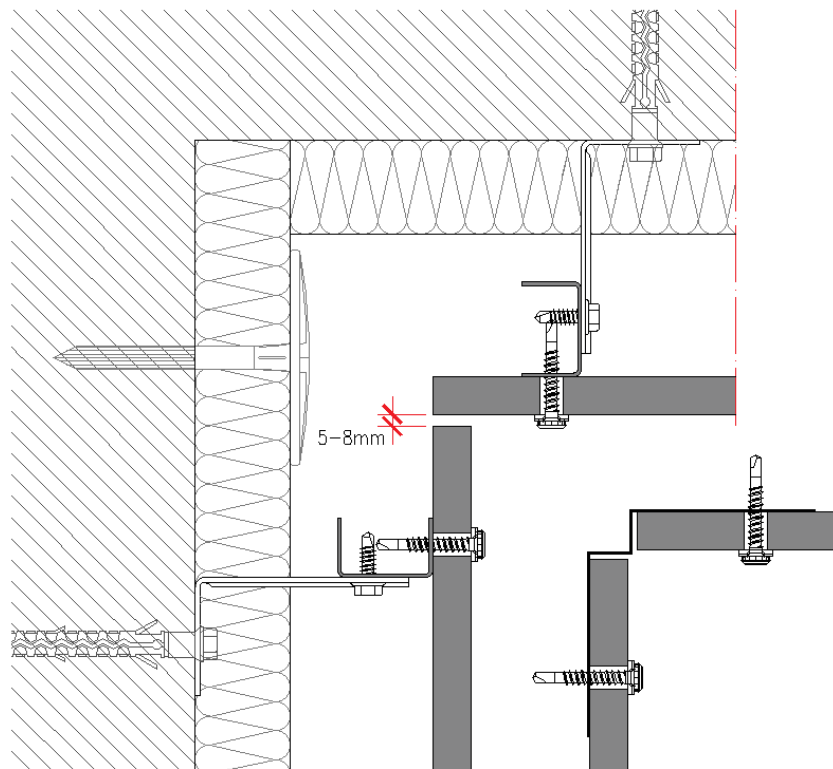
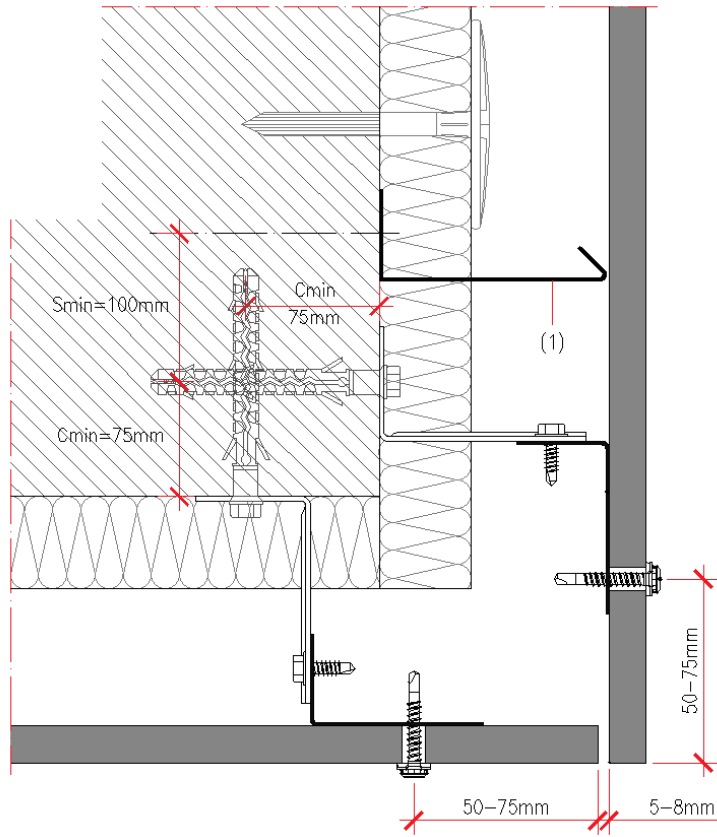
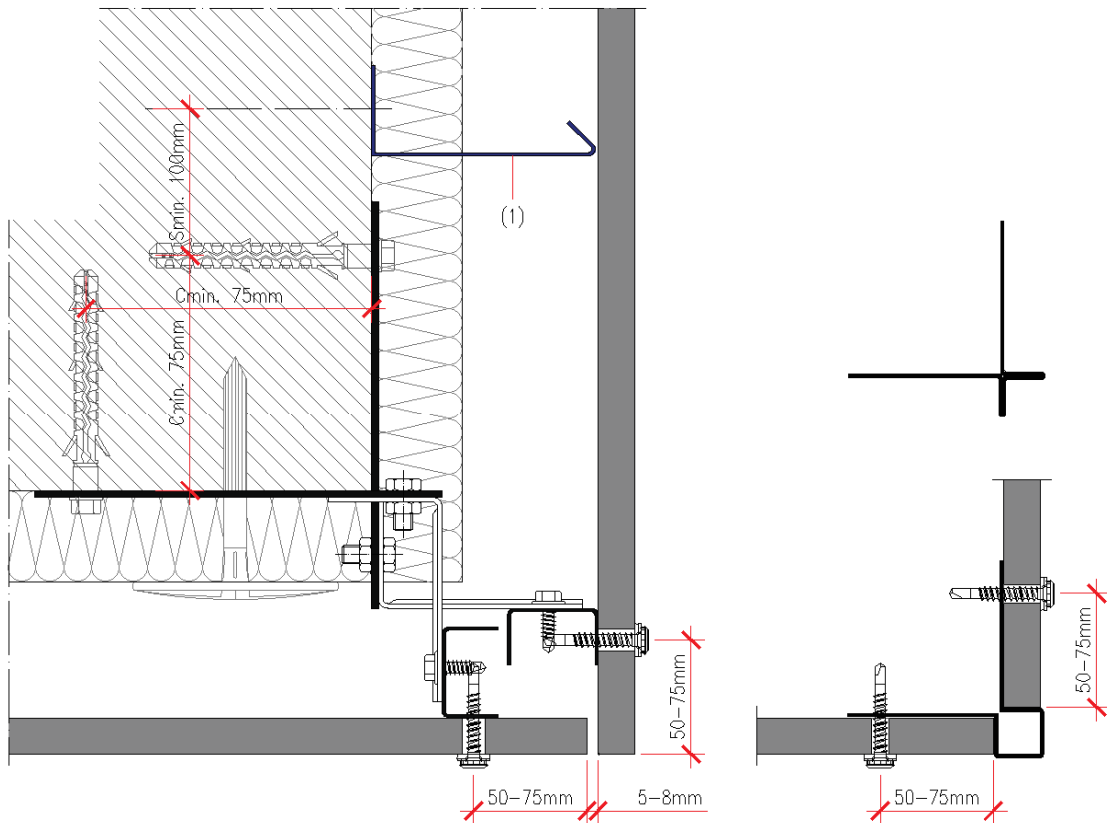

Figure 2.156 - Corner angle



(1) Compartmentalisation of the air foil
Figure 2.1.57 - Corner angle



(1) Compartmentalisation of the air foil
Figure 2.1.58 - Corner angle, variant

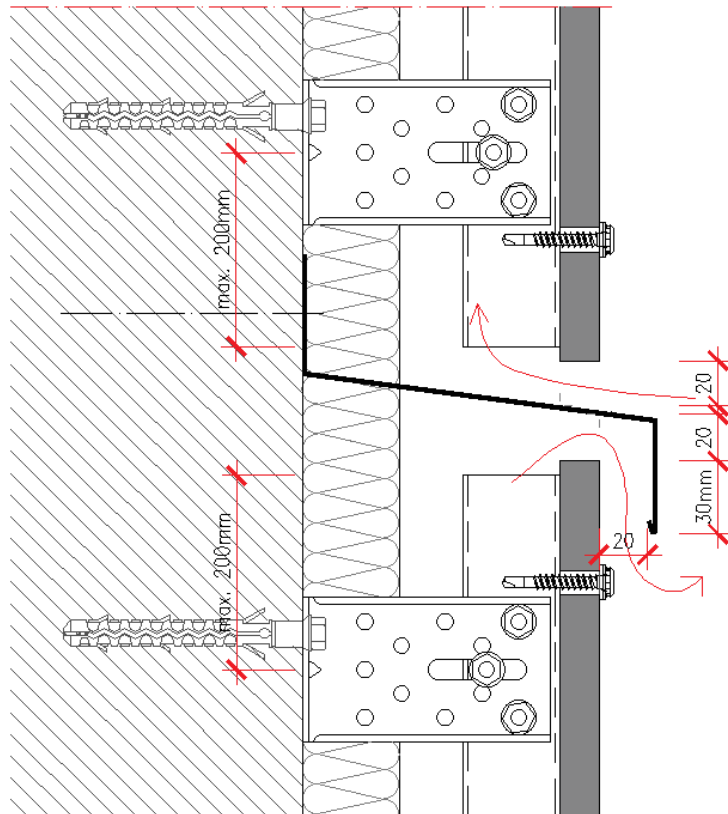

Figure 2.1.59 - Horizontal compartmentalisation of the air gap

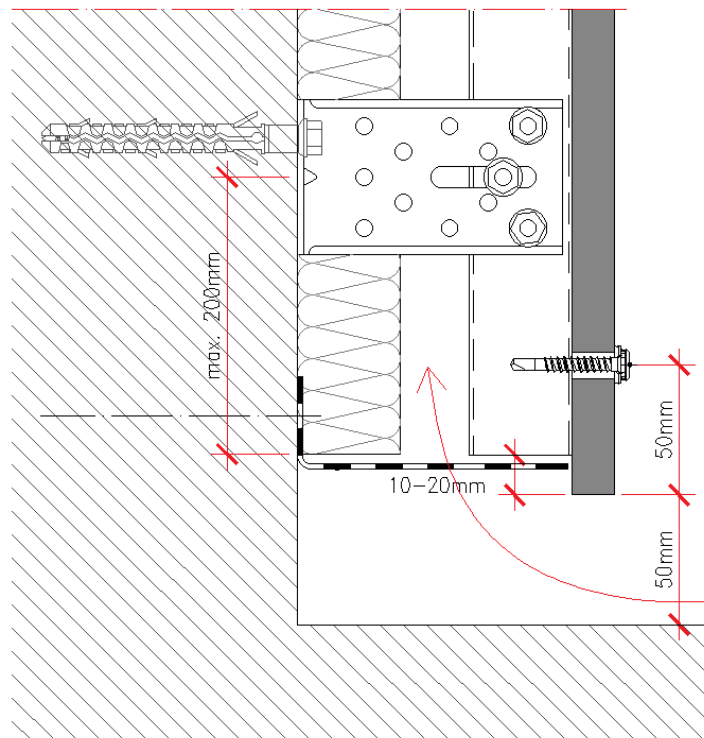

Figure 2.1.60 - Detail of the base, anti-rodent grid

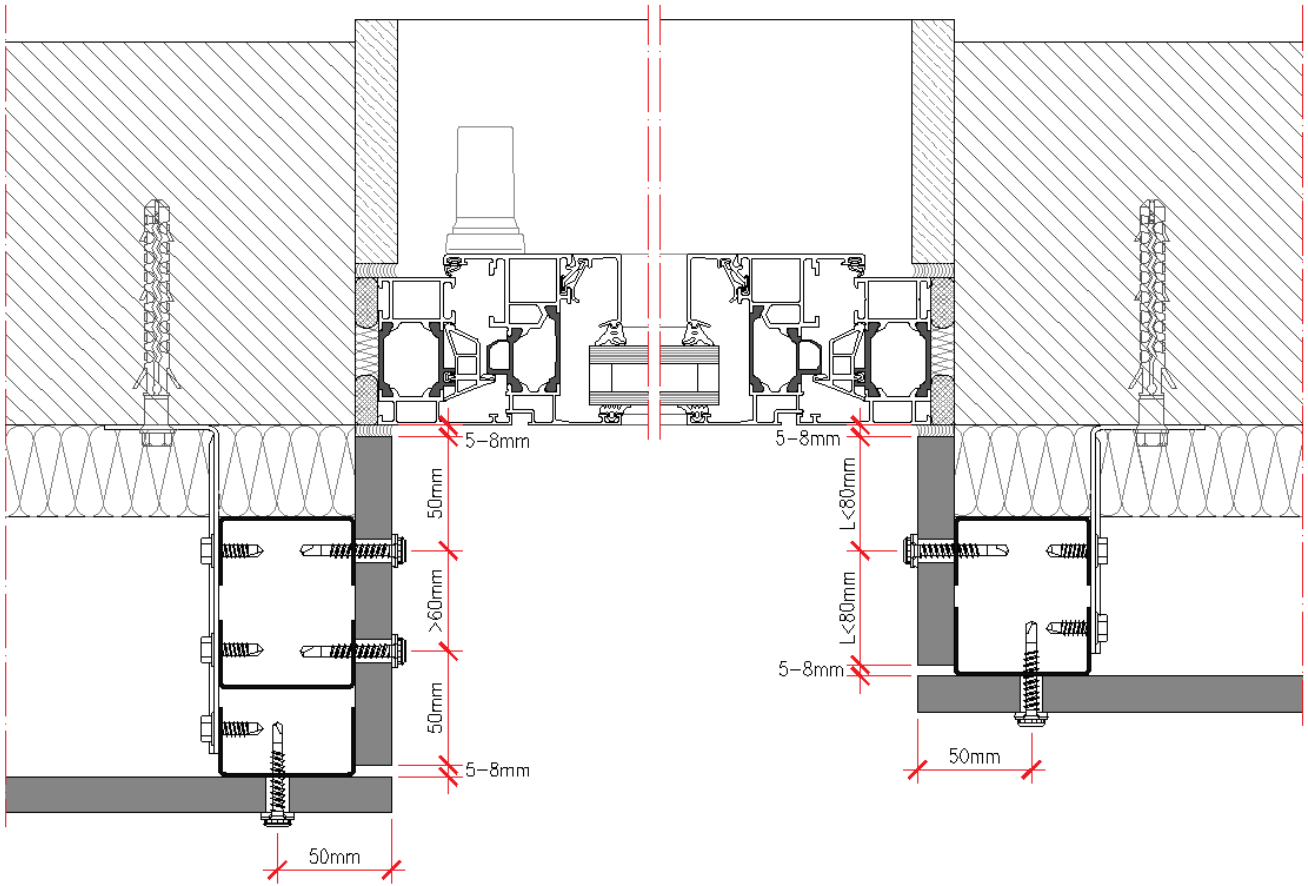

Figure 2.1.61 - Horizontal section, window opening

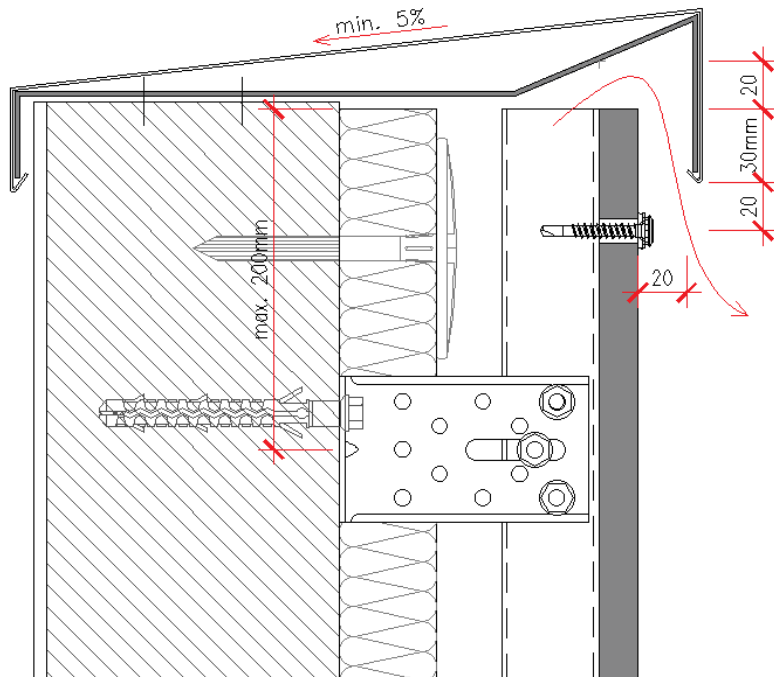

Figure 2.1.62 - Detail of the top

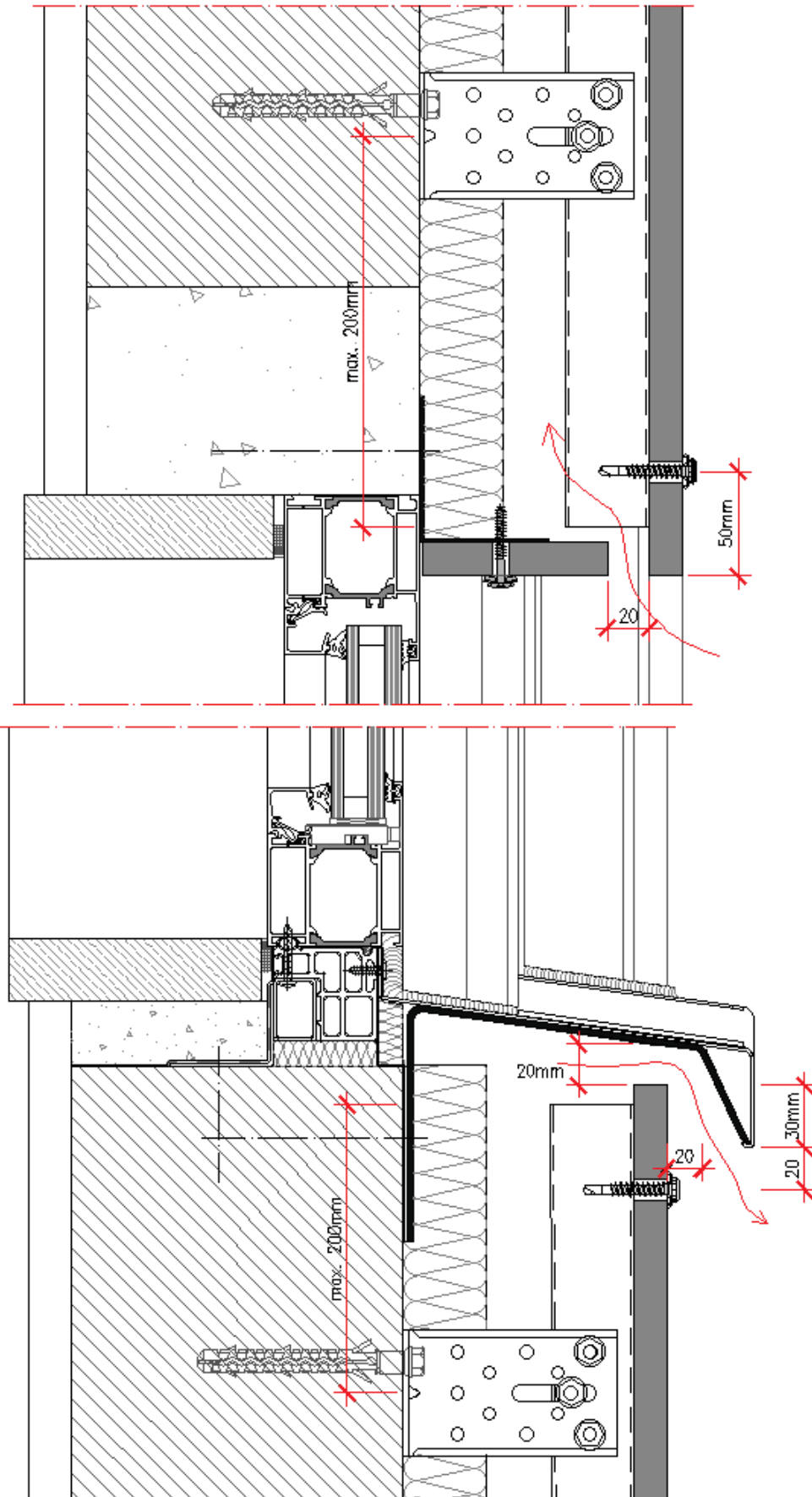

Figure 2.1.63 - Vertical section, window opening

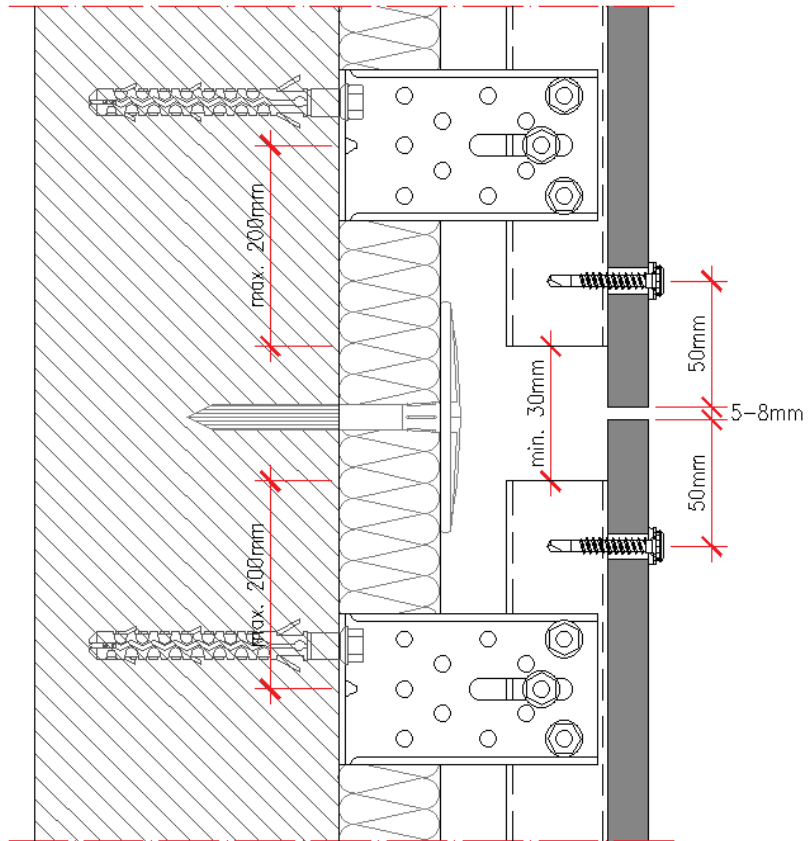

Figure 2.1.64 - Fractioning the structure: Profiles length ≤ 6 m

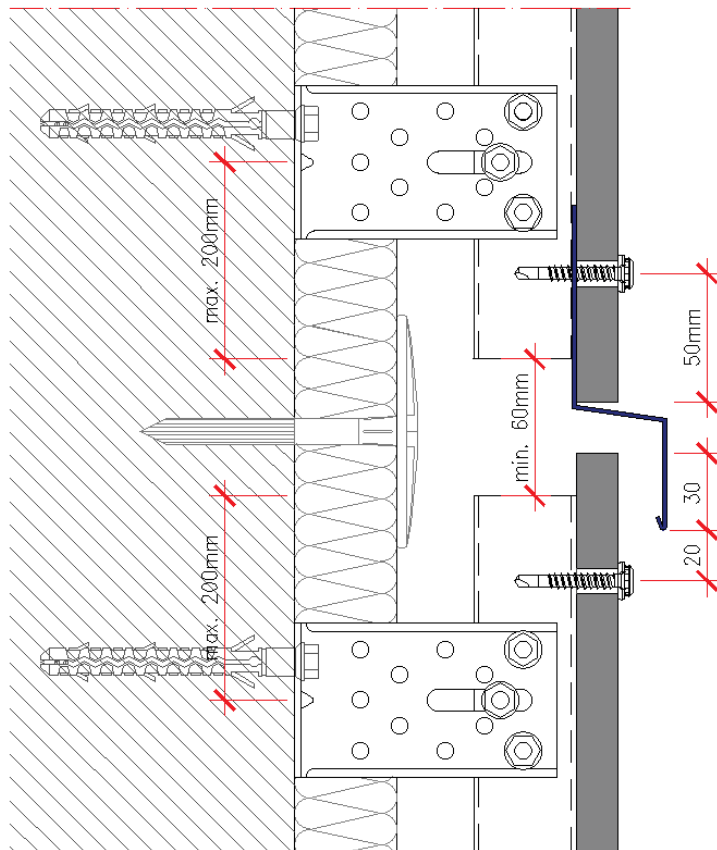
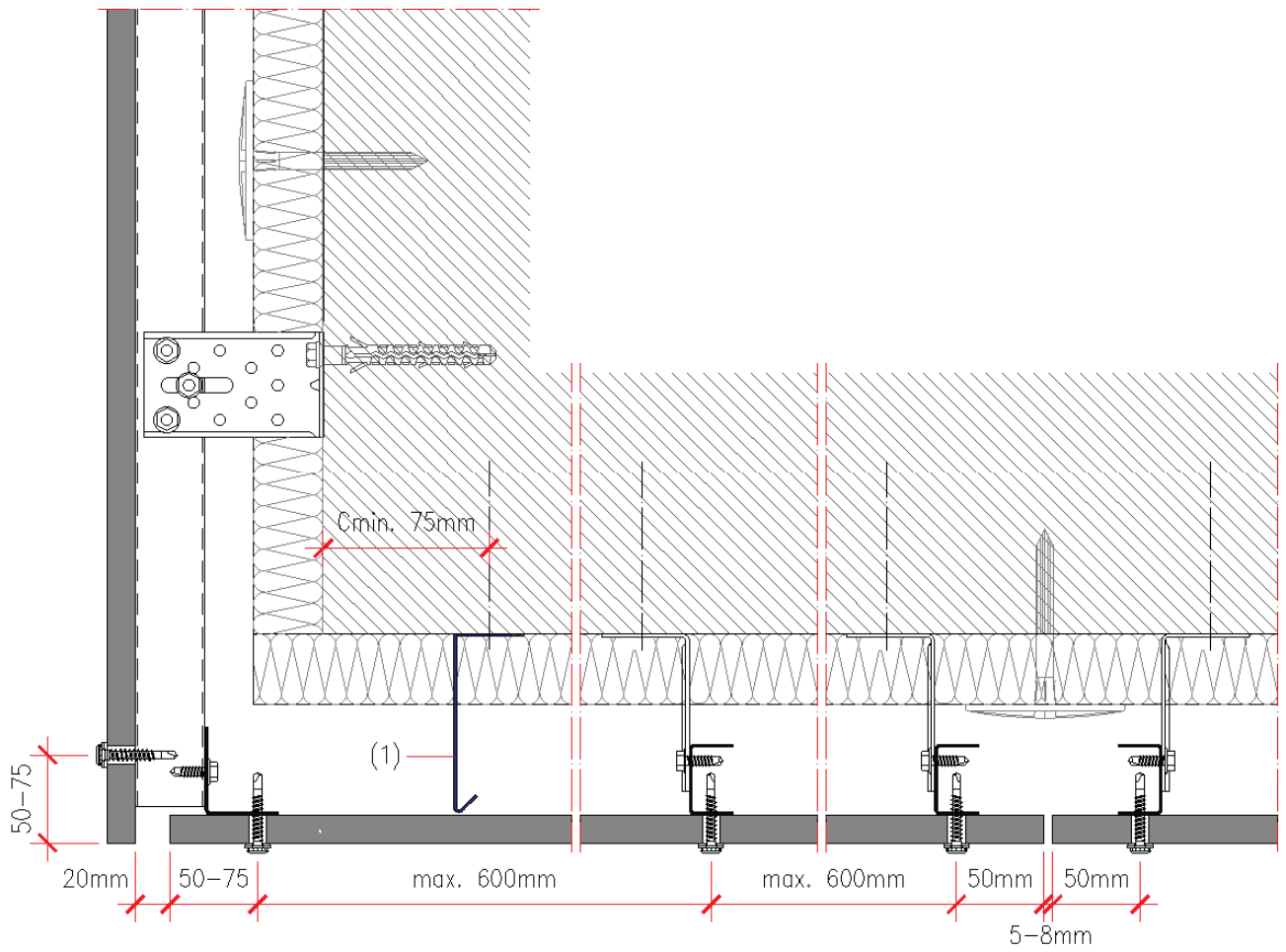

Figure 2.1.65 - Fractioning the structure: Profiles length > 6 m



(1) Compartmentalisation of the

Figure 2.1.66 - Detail of the façade - false ceiling connection

2.1.44 Details, Aluminium frame

Figures 2.1.67 to 2.1.82 show examples of various details and unique areas of the façade.

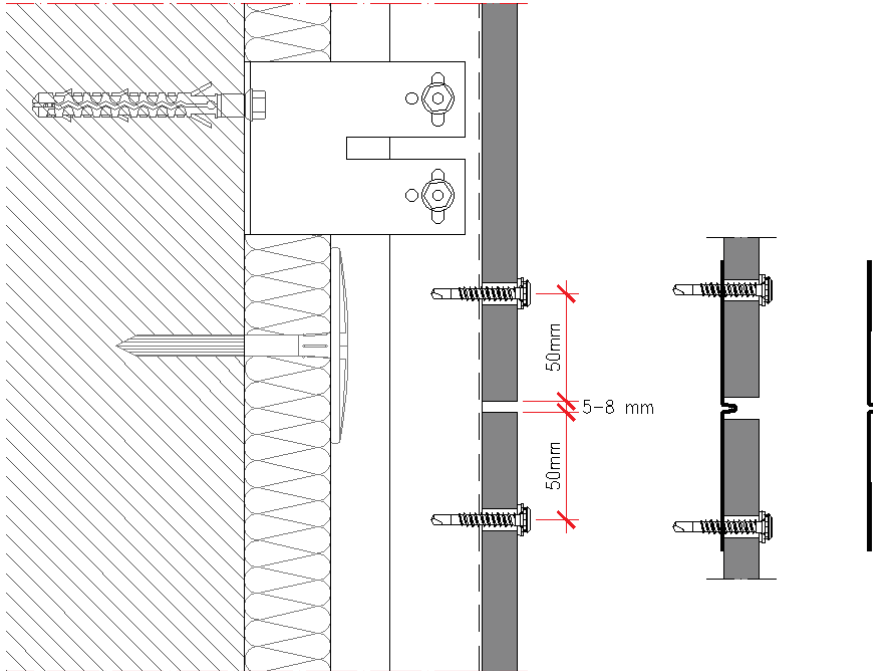

Figure 2.1.67 - Vertical section, joint between panels

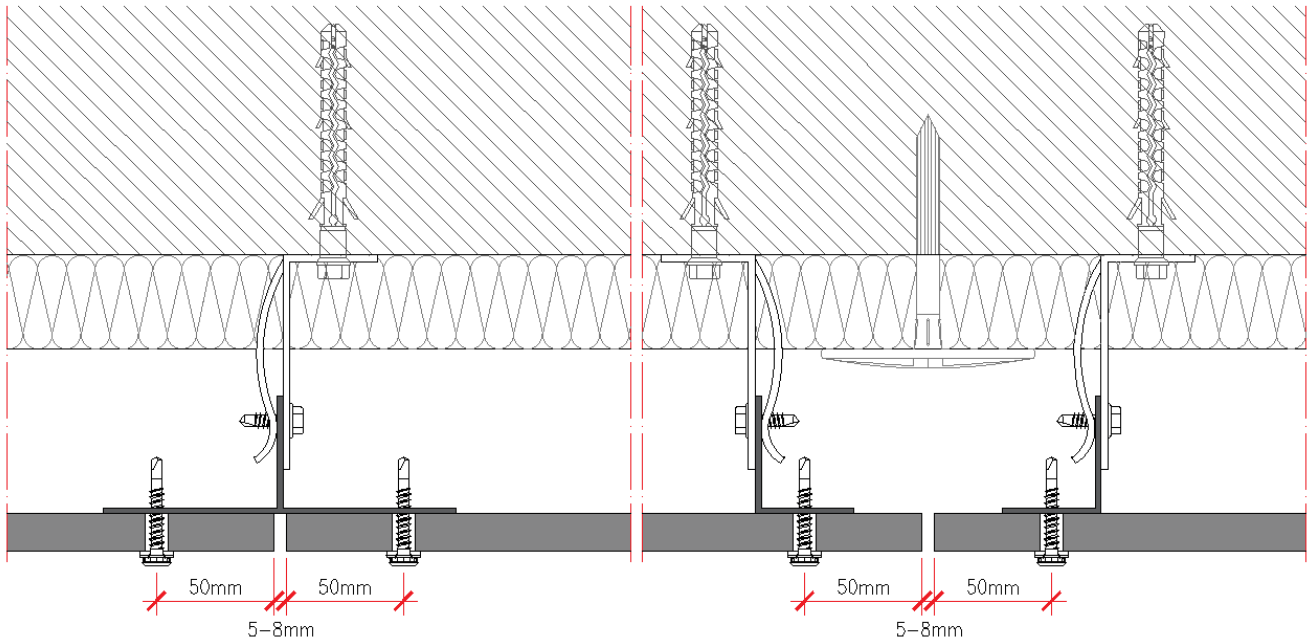

Figure 2.1.68 - Horizontal section, joint between panels

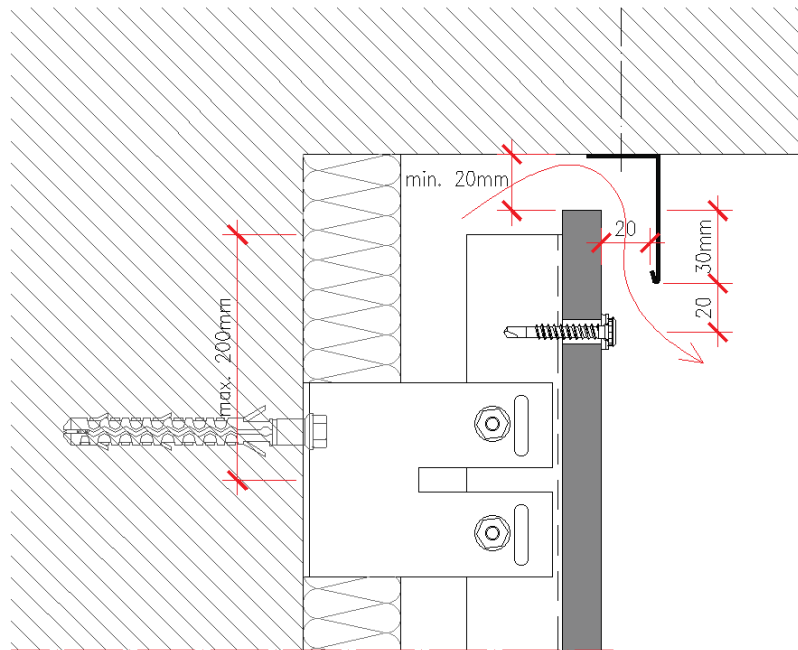

Figure 2.1.69 - Balcony finish

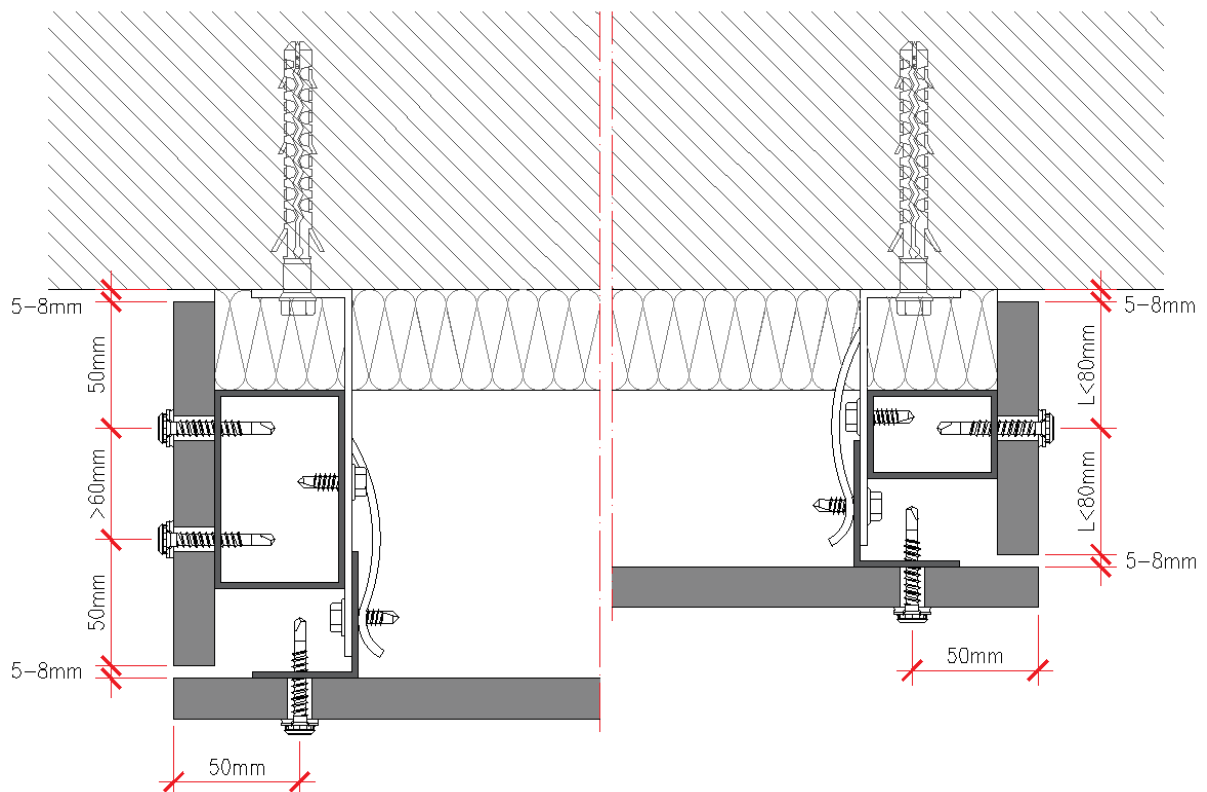

Figure 2.1.70 - Side finish

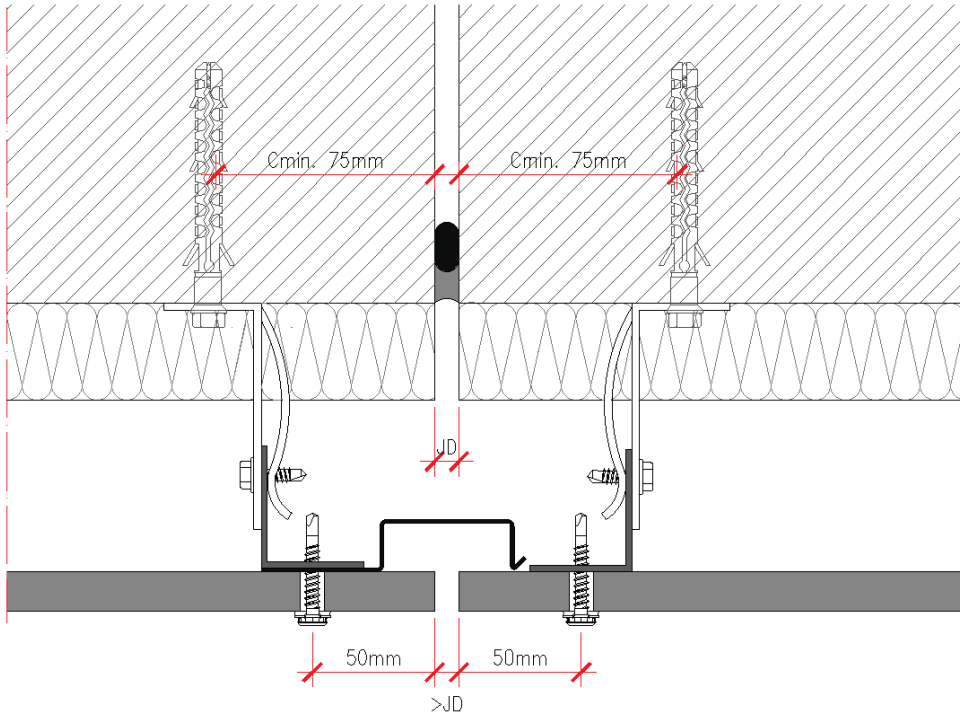

Figure 2.1.71 - Expansion joint

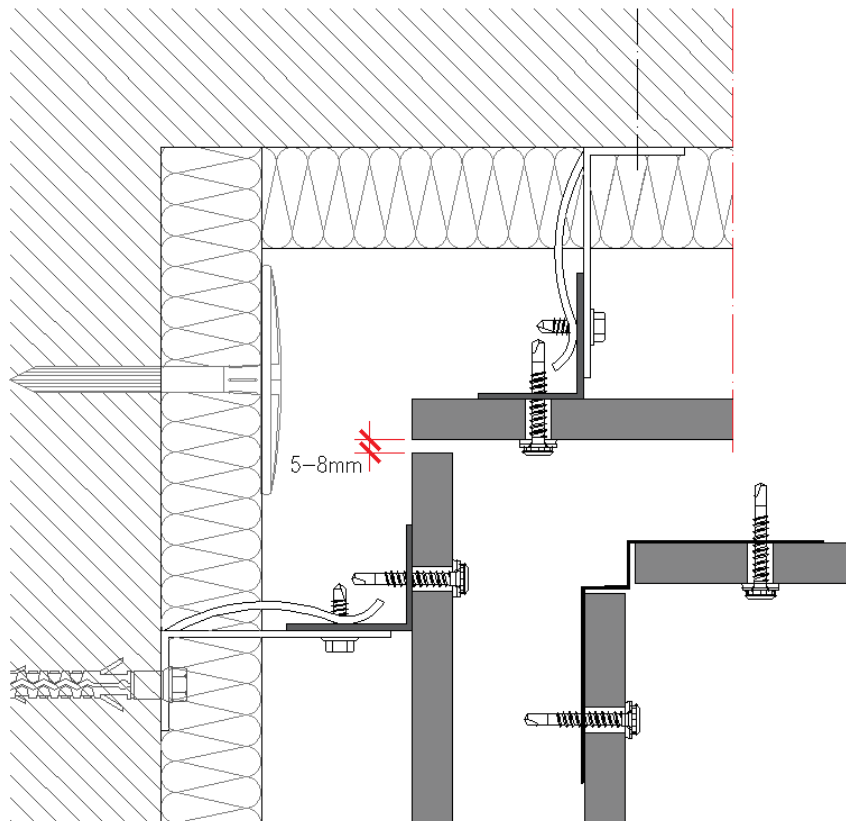
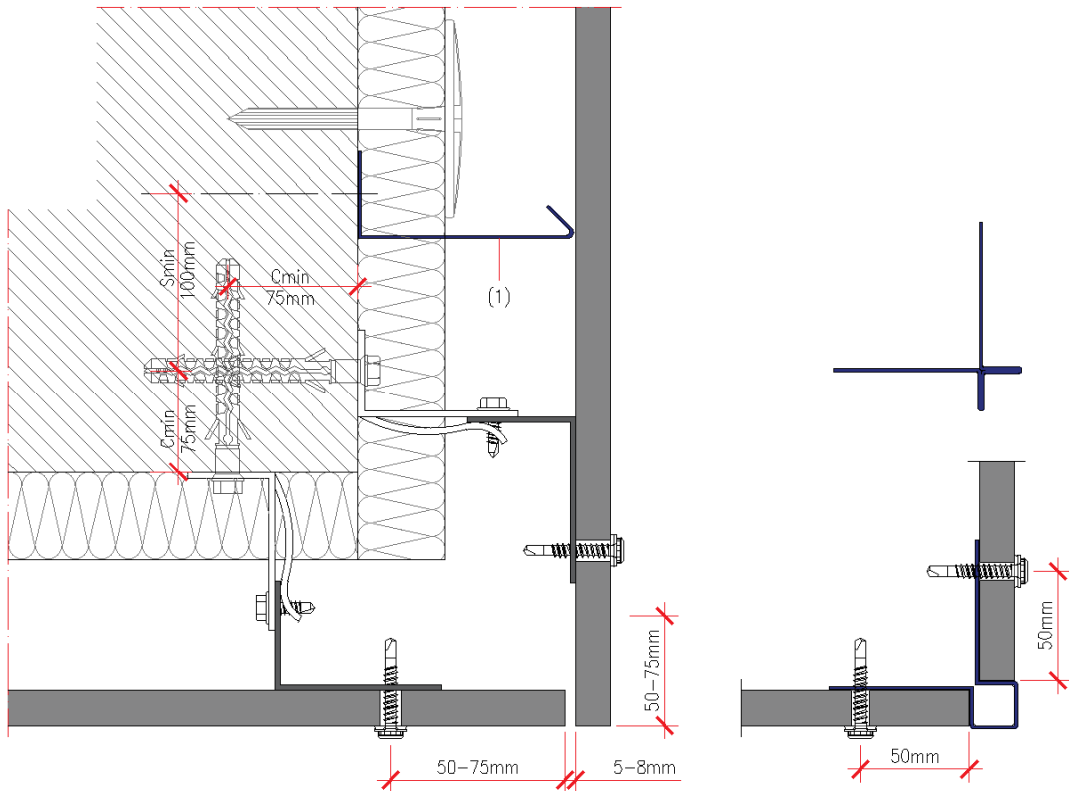
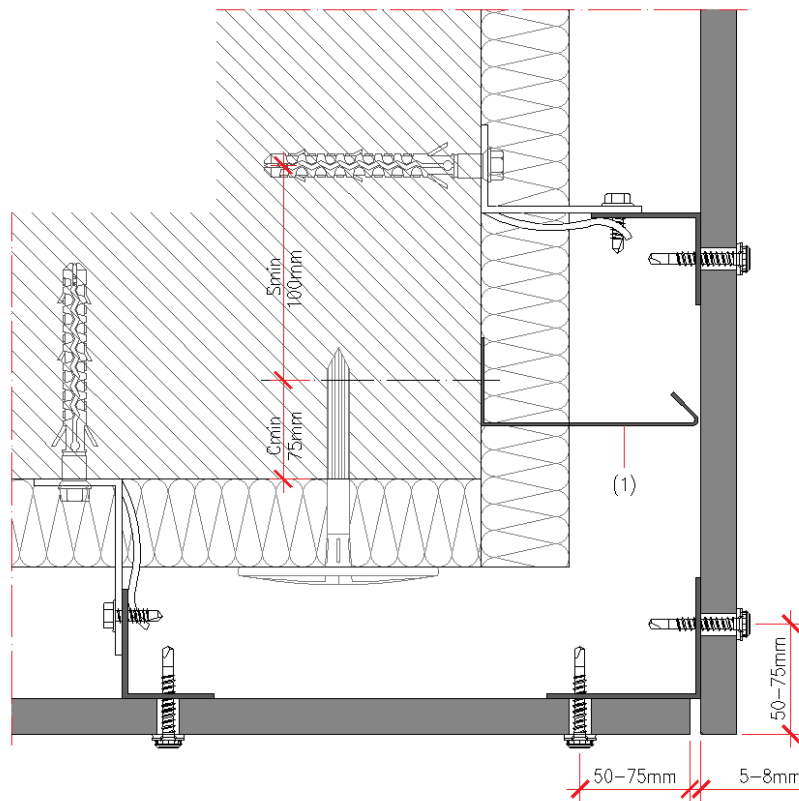

Figure 2.1.72 - Corner angle



(1) Compartmentalisation of the air foil
Figure 2.1.73 - Corner angle



(1) Compartmentalisation of the air foil
Figure 2.1.74 - Corner angle, variant

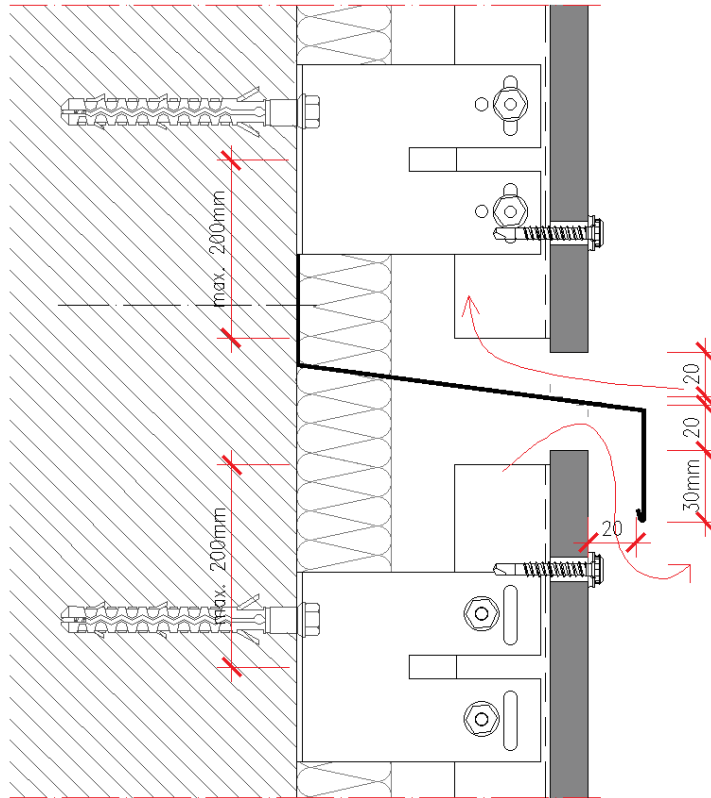

Figure 2.1.75 - Horizontal compartmentalisation of the air gap

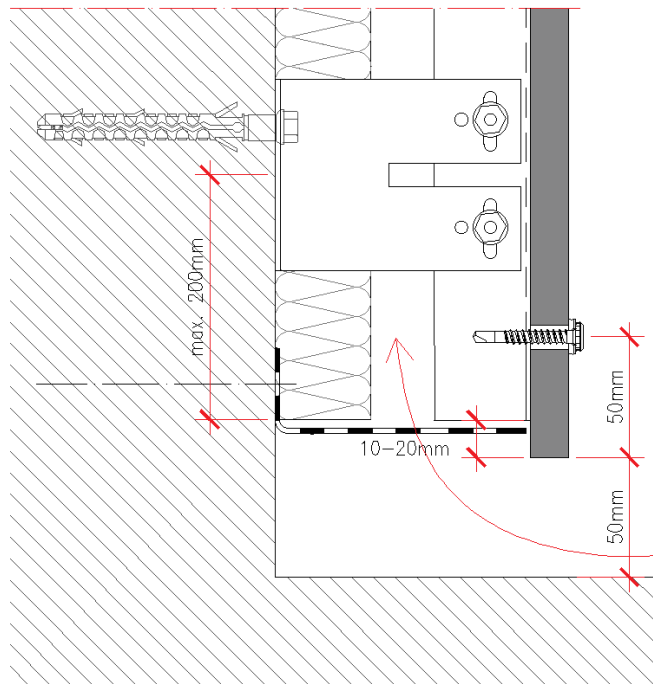

Figure 2.1.76 - Detail of the base, anti-rodent grid

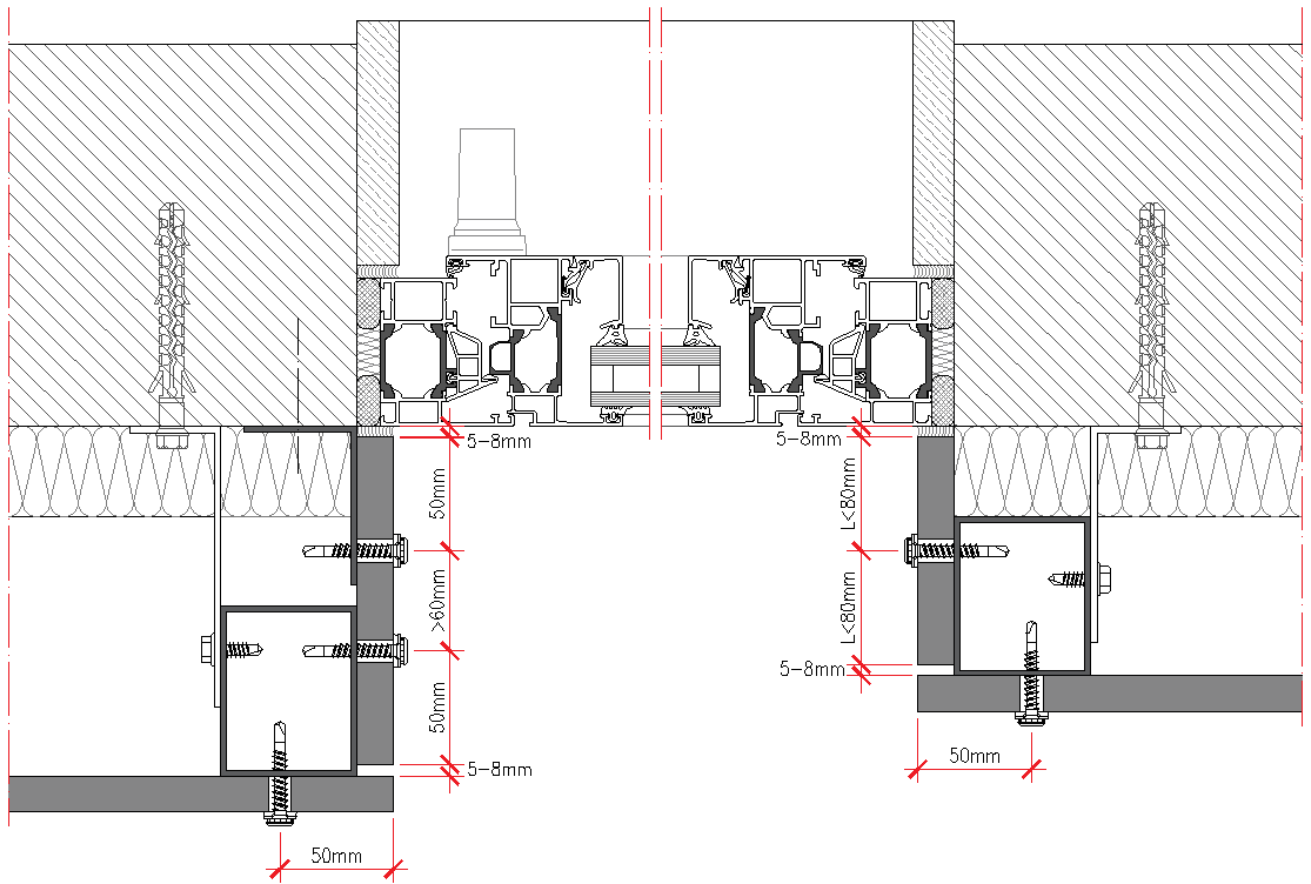

Figure 2.1.77 - Horizontal section, window opening

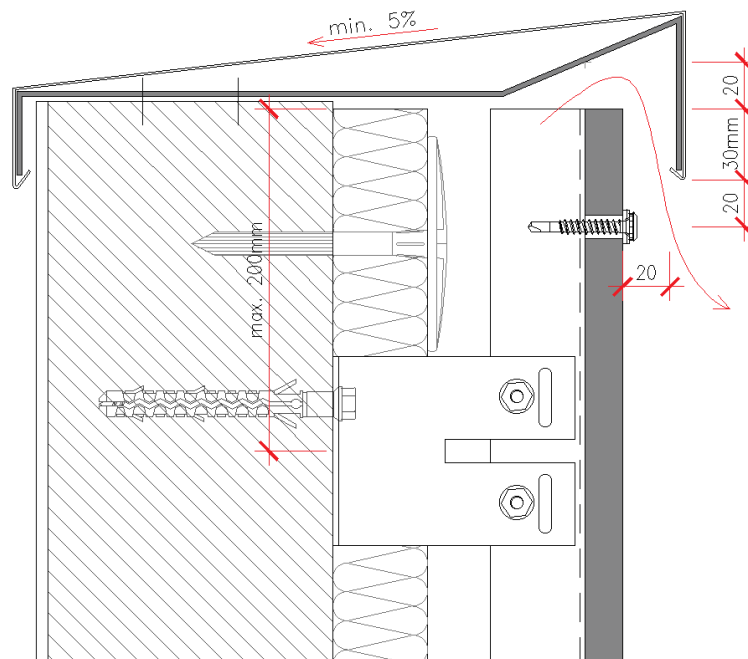

Figure 2.1.78 - Detail of the top

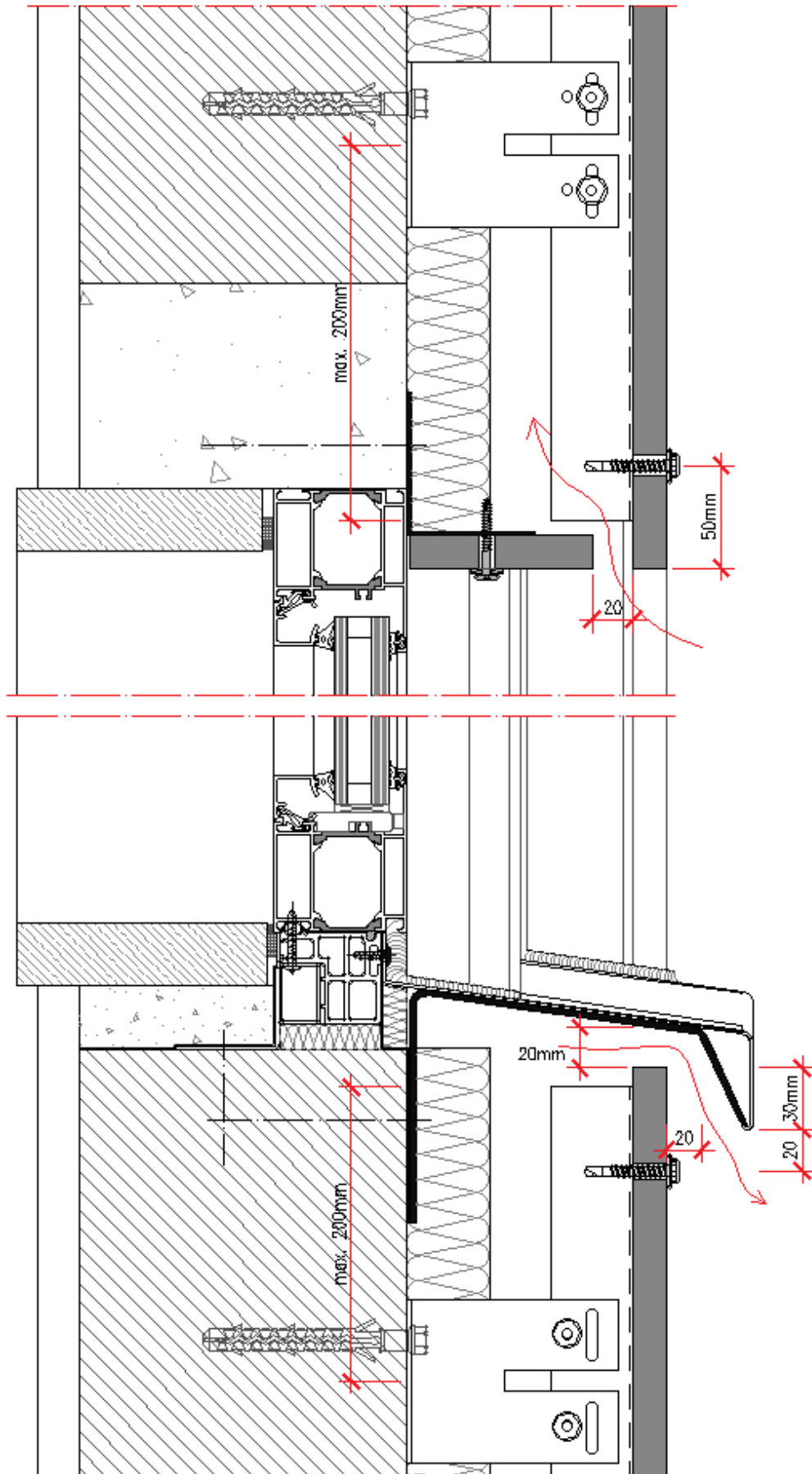

Figure 2.1.79 - Vertical section, window opening

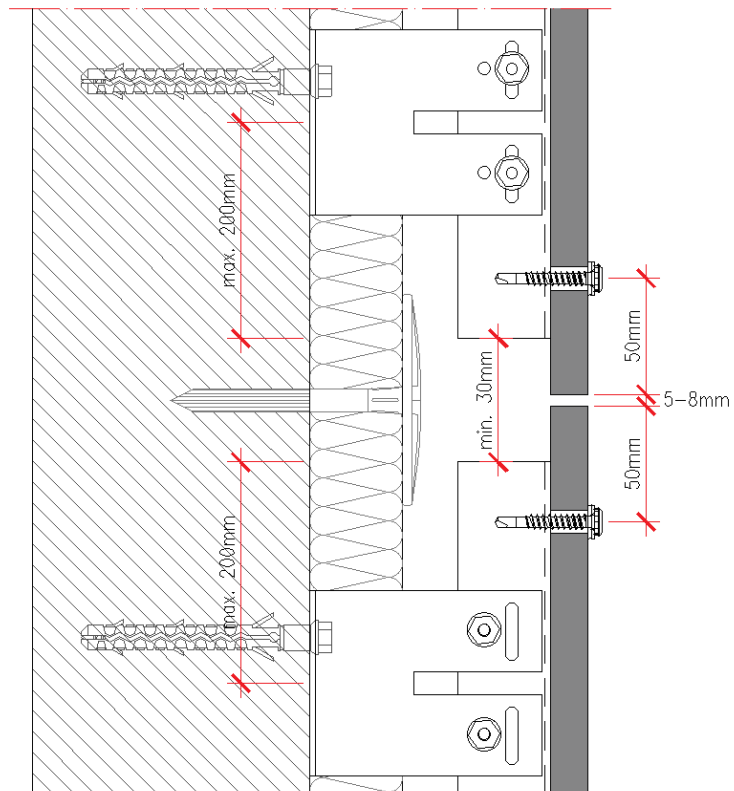

Figure 2.1.80 - Fractionation of the structure: Profiles length ≤ 6 m

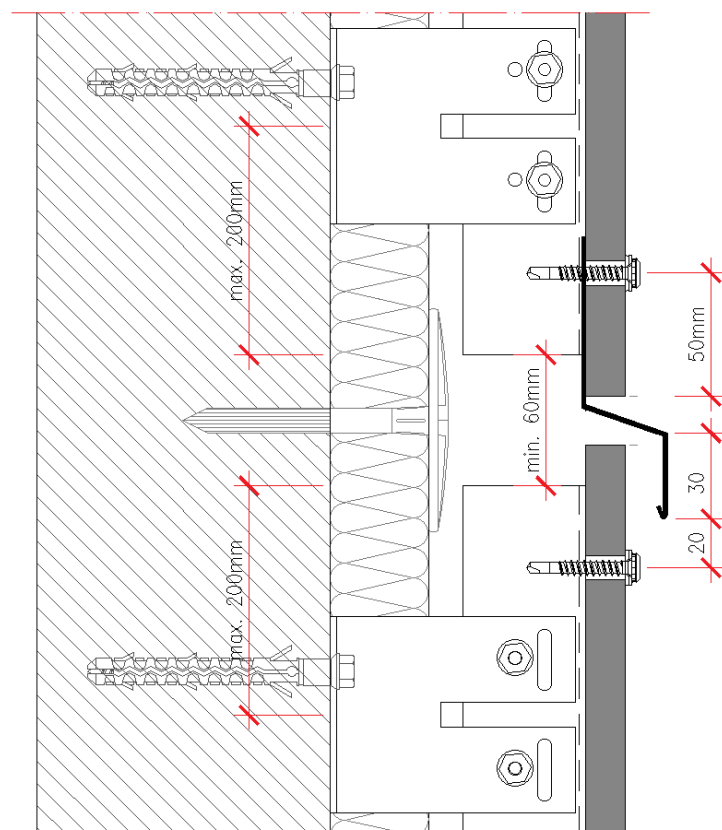

Figure 2.1.81 - Fractionation of the structure: Profiles length > 6 m

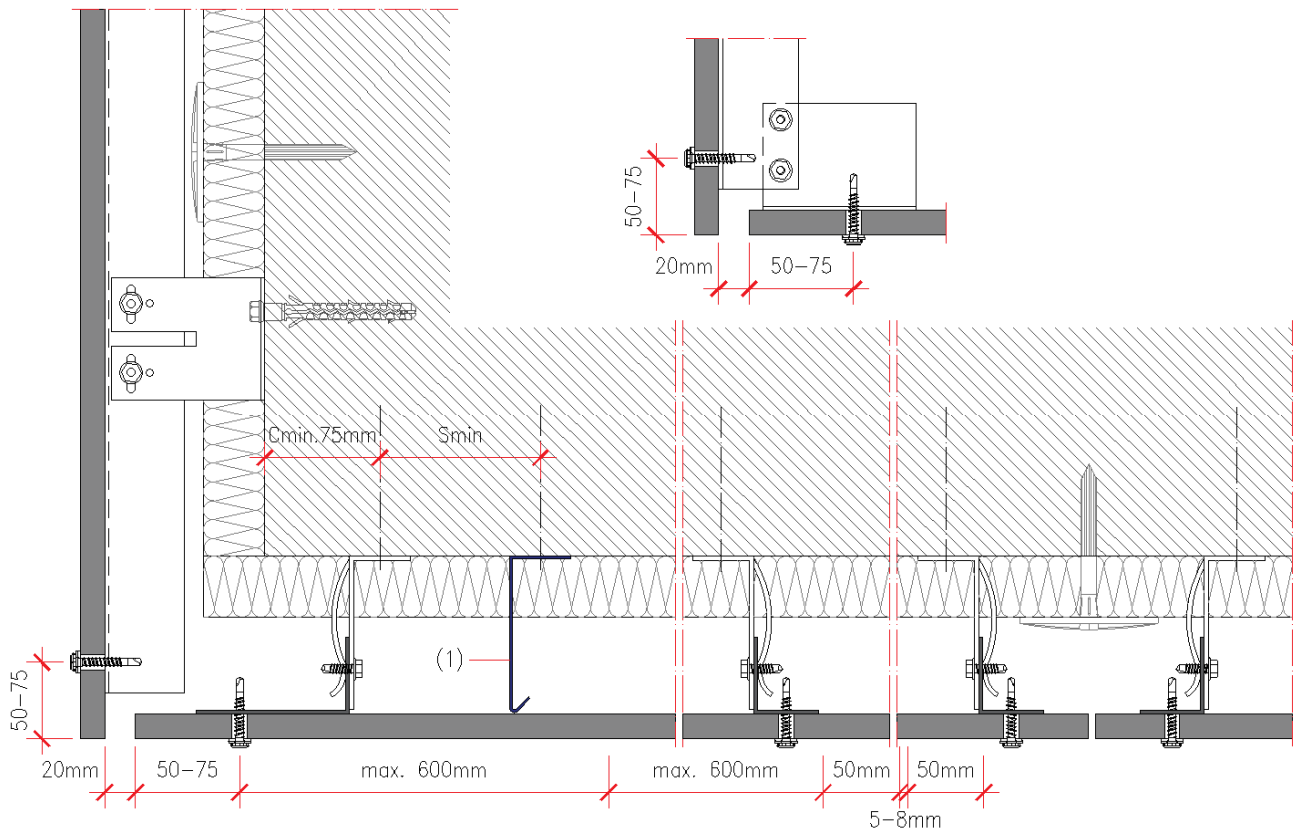

Figure 2.1.82 - Detail of the façade - false ceiling connection

WIND LOAD TABLES

Maximum pressure on panels when subjected to wind action (suction), N>3

Horizontal distance between screws 300 mm (12")											
Thickness of panel	(H x V)	Vertical distance between screws									
		300 mm	12"	400 mm	16"	500 mm	20"	600 mm	24"	700 mm	28"
		kN/m ²	psf	kN/m ²	psf	kN/m ²	psf	kN/m ²	psf	kN/m ²	psf
12 mm 1/2"	2 x 2	3,7	78	3,0	62	2,0	42	1,4	29	1,0	21
	2 x 3	3,4	71	2,6	53	2,0	43	1,7	36	1,5	30
	2 x N	3,4	71	2,6	53	2,0	43	1,7	36	1,5	30
	3 x 2	3,4	71	2,7	57	2,0	42	1,4	29	1,0	21
	N x 2	3,4	71	2,7	57	2,0	42	1,4	29	1,0	21
	3 x 3	3,1	64	2,3	48	1,8	39	1,5	32	1,3	28
	3 x N	3,1	64	2,3	48	1,8	39	1,5	32	1,3	28
	N x 3	3,1	64	2,3	48	1,8	39	1,5	32	1,3	28
16 mm 5/8"	2 x 2	7,8	163	6,2	130	4,7	99	3,3	69	2,4	50
	2 x 3	7,2	150	5,4	113	4,3	90	3,6	75	3,1	64
	2 x N	7,2	150	5,4	113	4,3	90	3,6	75	3,1	64
	3 x 2	7,2	150	5,8	120	4,7	99	3,3	69	2,4	50
	N x 2	7,2	150	5,8	120	4,7	99	3,3	69	2,4	50
	3 x 3	3,4	71	2,5	53	2,0	43	1,7	35	1,5	30
	3 x N	3,4	71	2,5	53	2,0	43	1,7	35	1,5	30
	N x 3	3,4	71	2,5	53	2,0	43	1,7	35	1,5	30

Table 1 – Maximum pressure, 300 mm spacing between screws horizontally

Horizontal distance between screws 400 mm (16")											
Thickness of panel	(H x V)	Vertical distance between screws									
		300 mm	12"	400 mm	16"	500 mm	20"	600 mm	24"	700 mm	28"
		kN/m ²	psf	kN/m ²	psf	kN/m ²	psf	kN/m ²	psf	kN/m ²	psf
12 mm 1/2"	2 x 2	3,0	62	2,4	50	2,0	42	1,4	29	1,0	21
	2 x 3	2,7	57	2,0	43	1,6	34	1,4	28	1,2	24
	2 x N	2,7	57	2,0	43	1,6	34	1,4	28	1,2	24
	3 x 2	2,6	53	2,0	43	1,7	36	1,4	29	1,0	21
	N x 2	2,6	53	2,0	43	1,7	36	1,4	29	1,0	21
	3 x 3	2,3	48	1,7	36	1,4	29	1,2	24	1,0	21
	3 x N	2,3	48	1,7	36	1,4	29	1,2	24	1,0	21
	N x 3	2,3	48	1,7	36	1,4	29	1,2	24	1,0	21
16 mm 5/8"	2 x 2	6,2	130	5,0	104	4,2	87	3,3	69	2,4	50
	2 x 3	5,8	120	4,3	90	3,5	72	2,9	60	2,5	52
	2 x N	5,8	120	4,3	90	3,5	72	2,9	60	2,5	52
	3 x 2	5,4	113	4,3	90	3,6	75	3,1	64	2,4	50
	N x 2	5,4	113	4,3	90	3,6	75	3,1	64	2,4	50
	3 x 3	2,5	53	1,9	40	1,5	32	1,3	27	1,1	23
	3 x N	2,5	53	1,9	40	1,5	32	1,3	27	1,1	23
	N x 3	2,5	53	1,9	40	1,5	32	1,3	27	1,1	23

Table 2 - Maximum pressure, 400 mm spacing between screws horizontally

Horizontal distance between screws 500 mm (20")											
Thickness of panel	(H x V)	Vertical distance between screws									
		300 mm	12"	400 mm	16"	500 mm	20"	600 mm	24"	700 mm	28"
		kN/m ²	psf	kN/m ²	psf	kN/m ²	psf	kN/m ²	psf	kN/m ²	psf
12 mm 1/2"	2 x 2	2,0	42	2,0	42	1,7	35	1,4	29	1,0	21
	2 x 3	2,0	42	1,7	36	1,4	28	1,1	24	1,0	20
	2 x N	2,0	42	1,7	36	1,4	28	1,1	24	1,0	20
	3 x 2	2,0	43	1,6	34	1,4	28	1,2	24	1,0	21
	N x 2	2,0	43	1,6	34	1,4	28	1,2	24	1,0	21
	3 x 3	1,8	39	1,4	29	1,1	23	0,9	19	0,8	17
	3 x N	1,8	39	1,4	29	1,1	23	0,9	19	0,8	17
	N x 3	1,8	39	1,4	29	1,1	23	0,9	19	0,8	17
16 mm 5/8"	2 x 2	4,7	99	4,2	87	3,5	72	3,0	62	2,4	50
	2 x 3	4,7	99	3,6	75	2,9	60	2,4	50	2,1	43
	2 x N	4,7	99	3,6	75	2,9	60	2,4	50	2,1	43
	3 x 2	4,3	90	3,5	72	2,9	60	2,5	52	2,2	45
	N x 2	4,3	90	3,5	72	2,9	60	2,5	52	2,2	45
	3 x 3	2,0	43	1,5	32	1,2	26	1,0	21	0,9	18
	3 x N	2,0	43	1,5	32	1,2	26	1,0	21	0,9	18
	N x 3	2,0	43	1,5	32	1,2	26	1,0	21	0,9	18

Table 3 - Maximum pressure, 500 mm spacing between screws horizontally

Horizontal distance between screws 600 mm (24")											
Thickness of panel	(H x V)	Vertical distance between screws									
		300 mm	12"	400 mm	16"	500 mm	20"	600 mm	24"	700 mm	28"
		kN/m ²	psf	kN/m ²	psf	kN/m ²	psf	kN/m ²	psf	kN/m ²	psf
12 mm 1/2"	2 x 2	1,4	29	1,4	29	1,4	29	1,2	25	1,0	21
	2 x 3	1,4	29	1,4	29	1,2	24	1,0	20	0,8	17
	2 x N	1,4	29	1,4	29	1,2	24	1,0	20	0,8	17
	3 x 2	1,7	36	1,4	28	1,1	24	1,0	20	0,9	18
	N x 2	1,7	36	1,4	28	1,1	24	1,0	20	0,9	18
	3 x 3	1,5	32	1,2	24	0,9	19	0,8	16	0,7	14
	3 x N	1,5	32	1,2	24	0,9	19	0,8	16	0,7	14
	N x 3	1,5	32	1,2	24	0,9	19	0,8	16	0,7	14
16 mm 5/8"	2 x 2	3,3	69	3,3	69	3,0	62	2,5	53	2,2	46
	2 x 3	3,3	69	3,1	64	2,5	52	2,1	43	1,8	37
	2 x N	3,3	69	3,1	64	2,5	52	2,1	43	1,8	37
	3 x 2	3,6	75	2,9	60	2,4	50	2,1	43	1,8	38
	N x 2	3,6	75	2,9	60	2,4	50	2,1	43	1,8	38
	3 x 3	1,7	35	1,3	27	1,0	21	0,8	18	0,7	15
	3 x N	1,7	35	1,3	27	1,0	21	0,8	18	0,7	15
	N x 3	1,7	35	1,3	27	1,0	21	0,8	18	0,7	15

Table 4 - Maximum pressure, 600 mm spacing between screws horizontally

Horizontal distance between screws 700 mm (28")											
Thickness of panel	(H x V)	Vertical distance between screws									
		300 mm kN/m ²	12" psf	400 mm kN/m ²	16" psf	500 mm kN/m ²	20" psf	600 mm kN/m ²	24" psf	700 mm kN/m ²	28" psf
12 mm 1/2"	2 x 2	1,0	21	1,0	21	1,0	21	1,0	21	0,9	20
	2 x 3	1,0	21	1,0	21	1,0	21	0,9	18	0,7	15
	2 x N	1,0	21	1,0	21	1,0	21	0,9	18	0,7	15
	3 x 2	1,5	30	1,2	24	1,0	20	0,8	17	0,7	15
	N x 2	1,5	30	1,2	24	1,0	20	0,8	17	0,7	15
	3 x 3	1,3	28	1,0	21	0,8	17	0,7	14	0,6	12
	3 x N	1,3	28	1,0	21	0,8	17	0,7	14	0,6	12
	N x 3	1,3	28	1,0	21	0,8	17	0,7	14	0,6	12
16 mm 5/8"	2 x 2	2,4	50	2,4	50	2,4	50	2,2	46	1,9	41
	2 x 3	2,4	50	2,4	50	2,2	45	1,8	38	1,5	32
	2 x N	2,4	50	2,4	50	2,2	45	1,8	38	1,5	32
	3 x 2	3,1	64	2,5	52	2,1	43	1,8	37	1,5	32
	N x 2	3,1	64	2,5	52	2,1	43	1,8	37	1,5	32
	3 x 3	1,5	30	1,1	23	0,9	18	0,7	15	0,6	13
	3 x N	1,5	30	1,1	23	0,9	18	0,7	15	0,6	13
	N x 3	1,5	30	1,1	23	0,9	18	0,7	15	0,6	13

Table 5 - Maximum pressure, 700 mm spacing between screws horizontally



Technical File

Chapter 2 - Façades

2.2 - Hidden Mechanical Fastening

Cement-bonded particleboards

Office

Lisboa Oriente

Av. Infante Dom Henrique 337, 3rd Floor
1800- 210 LISBON, PORTUGAL

Factory

VIROC Portugal S.A.
National Road 10
Km 44.7, Vale da Rosa
2914-519 SETÚBAL, PORTUGAL

In/ investwood

www.investwood.pt



INDEX

2.	VENTILATED FAÇADES.....	7
2.2	HIDDEN MECHANICAL FIXING SYSTEM.....	7
2.2.01	Aluminium support frame	8
2.2.02	Aluminium supporting squares	9
2.2.03	Thermal cutting of supporting squares	11
2.2.04	Anchors for fixing the supporting squares	12
2.2.05	Bushings for fixing thermal insulation	12
2.2.06	Rail profile arranged horizontally to support the clamps	13
2.2.07	Clamps.....	13
2.2.08	KARL system anchoring.....	15
2.2.09	Recommended thicknesses of the Viroc façade panels and their tolerances.....	15
2.2.10	Panel weight.....	15
2.2.11	Maximum format for the façade panels	15
2.2.12	Minimum format for the façade panels	16
2.2.13	Façade assembly operations.....	16
2.2.14	Marking and identification of façade elements	16
2.2.15	Mounting the supporting squares	16
2.2.16	Fixing the supporting squares to the supporting wall	16
2.2.17	Fitting the thermal insulation.....	16
2.2.18	Mounting the support profiles.....	16
2.2.19	Fixing the profiles to the supporting squares.....	16
2.2.20	Fixing the rail profiles horizontally	17
2.2.21	Cutting Viroc panels	17
2.2.22	Drilling Viroc panels	18
2.2.23	Surface preparation of Viroc panels	18
2.2.24	Varnishing or painting Viroc panels	18
2.2.25	Fixing the clamps to the Viroc panels	19
2.2.26	Panel installation.....	19
2.2.27	Joints between panels.....	21
2.2.28	Air foil ventilation	21
2.2.29	Angle profiles.....	21
2.2.30	Cleaning the panels after application.....	22
2.2.31	Replacing a panel	22
2.2.32	Impact resistance.....	22
2.2.33	Wind action.....	23
2.2.34	Example of Safety check of a Viroc panel to wind loads	23
2.2.35	Details	25

INDEX TO TABLES AND FIGURES

Figure 2.2.1 - 3D image of the Hilti/EuroFox MLZ system.....	8
Figure 2.2.2 - Primary structure.....	8
Figure 2.2.3 - Aluminium supporting squares, length: 40 to 240 mm.....	10
Figure 2.2.4 - Fixing the aluminium profiles to the supporting squares.....	10
Figure 2.2.5 - Fixing the aluminium profiles to the supporting squares.....	11
Figure 2.2.6 - Thermal cutting device for supporting squares.....	12
Figure 2.2.7 - Plastic anchor Ø10 mm.....	12
Figure 2.2.8 - Bushing fixing the thermal insulation to the support structure.....	13
Figure 2.2.9 - Rail profile for supporting the clamps.....	13
Figure 2.2.10 - Stainless steel screw 5.5x25, for fixing the rail profile.....	13
Figure 2.2.11 - Standard clamp.....	14
Figure 2.2.12 - Fixed clamp.....	14
Figure 2.2.13 - Adjustable clamp, same as fixed clamp with metric screw for adjustment.....	14
Figure 2.2.14 - KARL type AA anchor.....	15
Figure 2.2.15 - Primary structure fixed with supporting squares to the support.....	17
Figure 2.2.16 - View of the rail profile arranged horizontally.....	17
Figure 2.2.17 - Circular saw with tungsten cutting disc.....	18
Figure 2.2.18 - KARL system stopper hole.....	18
Figure 2.2.19 - Tool for driving the anchors into the Viroc panel.....	19
Figure 2.2.20 - Location of clamps, panel arranged horizontally.....	20
Figure 2.2.21 - Location of clamps, panel arranged vertically.....	20
Figure 2.2.22 - Perforated anti-rodent profile.....	21
Figure 2.2.23 - Corner angle profiles.....	22
Figure 2.2.24 - Corner angle profiles.....	22
Table 3 - Permissible pressure, 500 mm spacing between horizontal fixings.....	24
Figure 2.2.25 - Vertical section.....	25
Figure 2.2.26 - Horizontal section.....	26
Figure 2.2.27 - Detail of the top trim.....	26
Figure 2.2.28 - Detail of the balcony finish.....	27
Figure 2.2.29 - Detail of base.....	28
Figure 2.2.30 - Detail of expansion joint.....	28
Figure 2.2.31 - Detail of side trim.....	29
Figure 2.2.32 - Detail of corner angle.....	30
Figure 2.2.33 - Detail of the corner angle.....	31
Figure 2.2.34 - Horizontal compartmentalization of the air foil.....	32
Figure 2.2.35 - Detail of window opening, vertical section.....	33
Figure 2.2.36 - Detail of window opening, horizontal section.....	34
Figure 2.2.37 - Fractionation of the structure.....	35
Figure 2.2.38 - Detail of Façade-Teiling connection.....	36
TABLES.....	37
Table 1 - Maximum pressure, 300 mm spacing between horizontal fixings.....	37
Table 2 - Maximum pressure, 400 mm spacing between horizontal fixings.....	37
Table 3 - Maximum pressure, 500 mm spacing between horizontal fixings.....	38
Table 4 - Maximum pressure, 600 mm spacing between horizontal fixings.....	38
Table 5 - Maximum pressure, 700 mm spacing between horizontal fixings.....	38

Credits**Author**

José Pinheiro Soares

suporte.tecnico@investwood.pt

Review and English Translation

CS Traduções

geral@cstraducoes.pt

Viroc Portugal S.A. reserves the right to modify this document without prior notice.

This Technical File invalidates all previous technical documents.

Issue: February 15, 2024



2. VENTILATED FAÇADES

Viroc panels can be used to clad the façade of buildings, forming a panel-ventilated façade.

Viroc panels have a heterogeneous appearance with differences in tone on the same face, between faces of the same panel or between different productions.

Surfaces may show some irregularities and scaling.

With exposure to the sunlight, the colour of the panels changes slightly, becoming lighter. This variation in tone varies from colour to colour.

When applied to ventilated façades, Viroc panels must be varnished or painted, unless they are applied under the conditions described in Chapter 2.3.

The panels, when placed outdoors, are subject to dimensional variations of +1.0 mm to -3.0 mm per linear metre, when the panel is sealed on both sides and tops. The panel fixing system must allow for this dimensional variation.

Ventilated façades are made up of:

- Viroc panels
- Support structure for the panels and their fixing elements;
- Anchors for fixing the panels to the support structure;
- Thermal insulation;
- Ventilation air layer;
- Complementary profiles for the treatment of singular points.

2.2 HIDDEN MECHANICAL FIXING SYSTEM

In this system, the Viroc panels that constitute the façade are fixed to a structure made up of aluminium profiles at the back, which in turn are fixed to a supporting wall.

A ventilated air gap is formed between the cladding panels and the supporting wall, which will give the building its thermal comfort characteristics.

The concealed fastening system consists of the following elements

- a) Aluminium support structure made up of vertically arranged profiles;
- b) Supporting squares and their fixing elements;
- c) Thermal insulation;
- d) Aluminium rail profile, arranged horizontally, to support the clamps;
- e) Supporting clamps;
- f) KARL type AA anchors;
- g) M6 screws;
- h) Viroc panels

Figure 2.2.1 representation of a 3D image of the system.

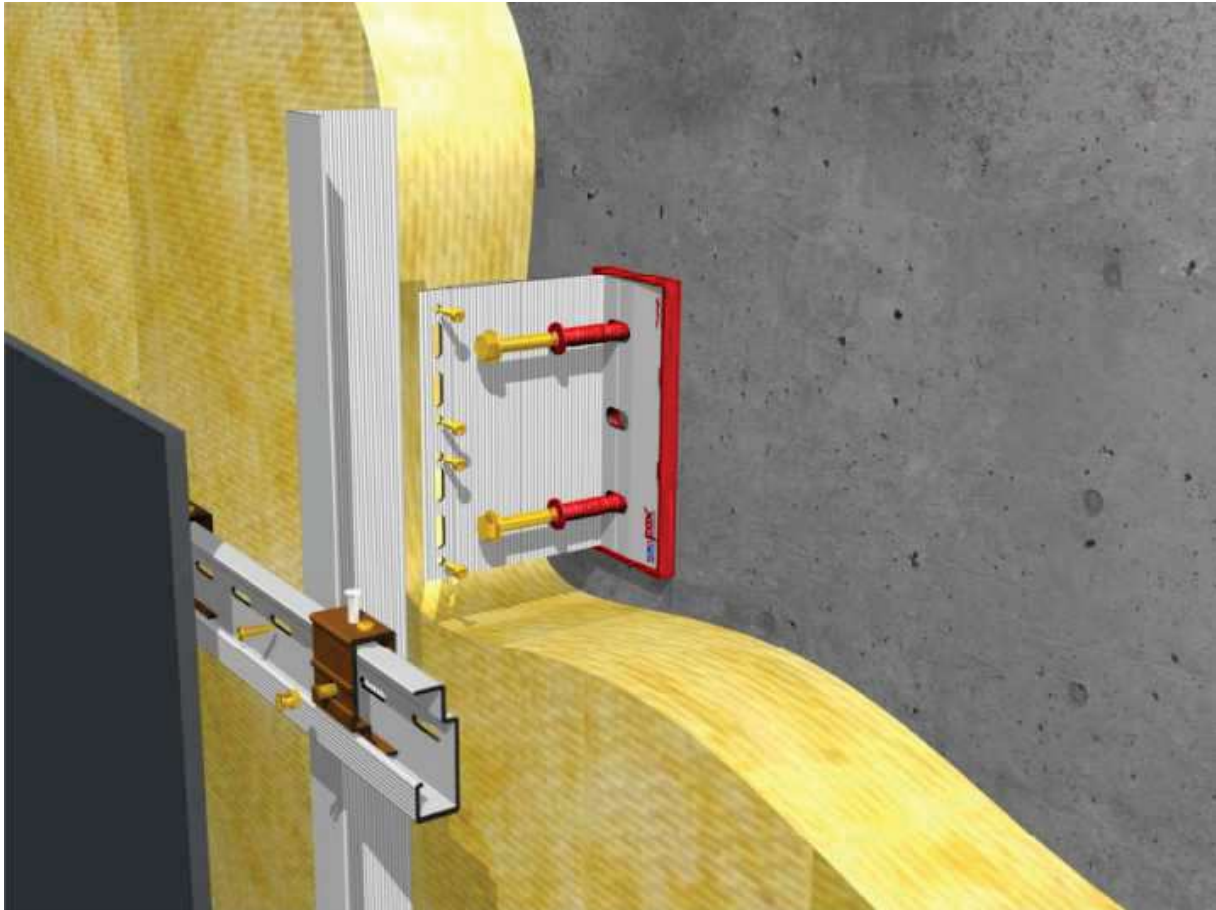

Figure 2.2.1 - 3D image of the Hilti/EuroFox MLZ system

2.2.01 Aluminium support frame

The primary structure may consist of aluminium profiles of at least 6000 series aluminium alloy with yield strength equal to or greater than 180 MPa.

The cross-section of the profiles is generally T or L-shaped with a minimum thickness of 2 mm. Other cross-section shapes can be used, provided they have the same performance and durability (see figure 2.2.2).

Because aluminium has a high coefficient of expansion, the design of the structure must allow for the expansion of the profiles. In this sense, the aluminium profiles should not be longer than 6 m and there should be only one fixing point for the supporting squares with restricted expansion movements, located near the top end of the profile. The other fixings must allow the profiles to expand.

The maximum horizontal deformation of the support structure, when subjected to wind loads, may not exceed 3 mm.

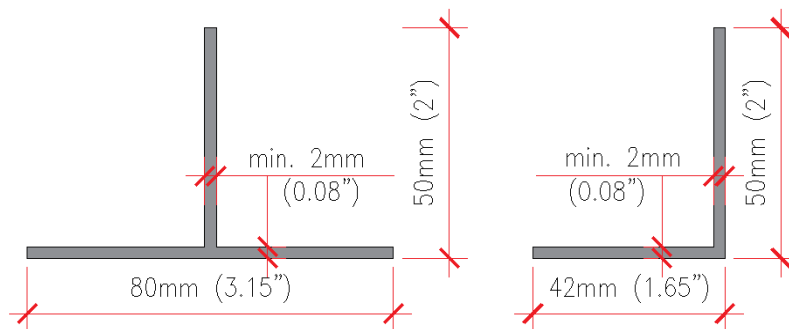

Figure 2.2.2 - Primary structure

6000 series aluminium alloy with $R_{p0.2} \geq 180$ MPa

The manufacturers described below have aluminium structures that can be used:

ETANCO - FACALU C+ system;

<https://www.etanco.fr/>

HILTI/EUROFOX - Eurofox-MLZ/k-v-00 system;

<https://www.hilti.ie/content/hilti/E1/IE/en/business/business/engineering/eurofox.html>

<https://youtu.be/O29BOB609wo?si=9E4GdclOLJBfQKX->

ALLFACE - F1.40 system;

<https://www.allface.com/>

<https://www.allface.com/assets/downloads/systems/F1.40.pdf>

ALIVA - Ali GLASS S/Ali Stone System 3;

<https://www.aliva.it/>

GIP - GIP-VECO-2000 system,

<https://www.gip-fassade.com/de/>

<https://www.gip-fassade.com/en/systems/veco-2000>

BWM - ATK 103 system;

<https://www.bwm.de/>

<https://www.bwm.de/produkte/atk-103-ansicht/>

NFT-SL - Rapid 850 NFT-SL system;

<https://nft-sl.de/en/>

<https://nft-sl.de/en/back-fixing/850>

U-KON - ATS/LT-228 system;

<https://www.u-konsystems.ca/>

<https://www.u-konsystems.ca/228>

PLASTERSTRIP

<https://www.plasterstrip.com/product-category/fastframe/helping-hand-systems/mechanical-secret-fix/>

Profiles from other manufacturers may be used, provided they are suitable and of similar quality and strength.

2.2.02 Aluminium supporting squares

The location of these elements determines the final position of the support profiles, so they must be positioned precisely.

The supporting squares for fixing the aluminium structure must be made of an aluminium alloy equal to or greater than 6060 T5. Supporting squares are generally L-shaped, with several holes and a minimum thickness of 3 mm (see figure 2.2.3).

The supporting squares are dimensioned taking into account the façade own weight, based on a partial security coefficient of 1.5. The vertical deformation of the bracket may not exceed 3 mm for the maximum vertical load.

Because aluminium has a high coefficient of expansion, the design of the structure must allow for the expansion of the profiles. In this sense, the aluminium profiles should not be longer than 6 m and there should be only one point of attachment to the supporting squares with restricted expansion movements, near the top end of the profile. The other fixings must allow the profiles to expand (see figures 2.2.4 and 2.2.5).



Figure 2.2.3 - Aluminium supporting squares, length: 40 to 240 mm
Alloy 6060 T5, esp. Minimum 3 mm

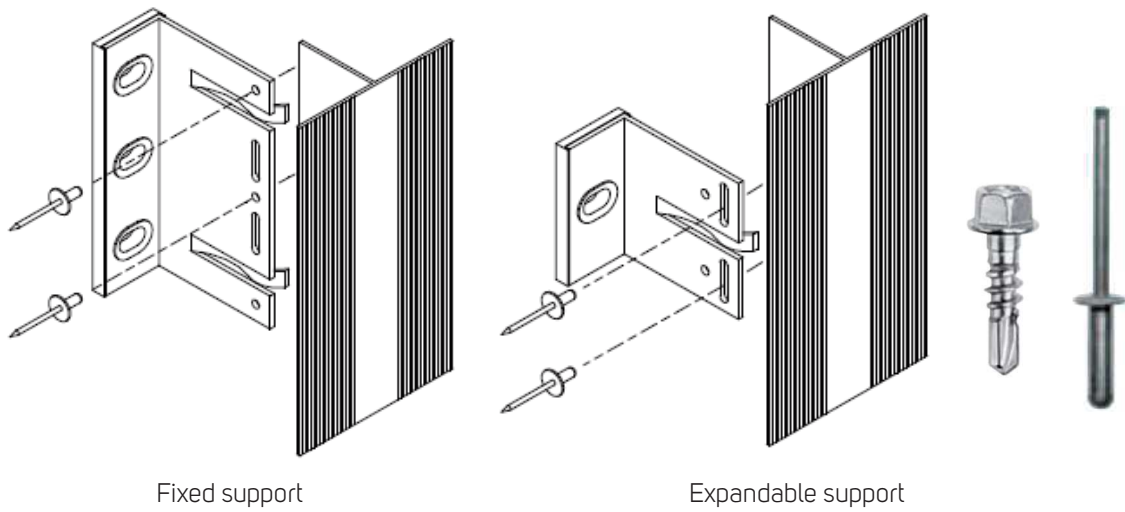
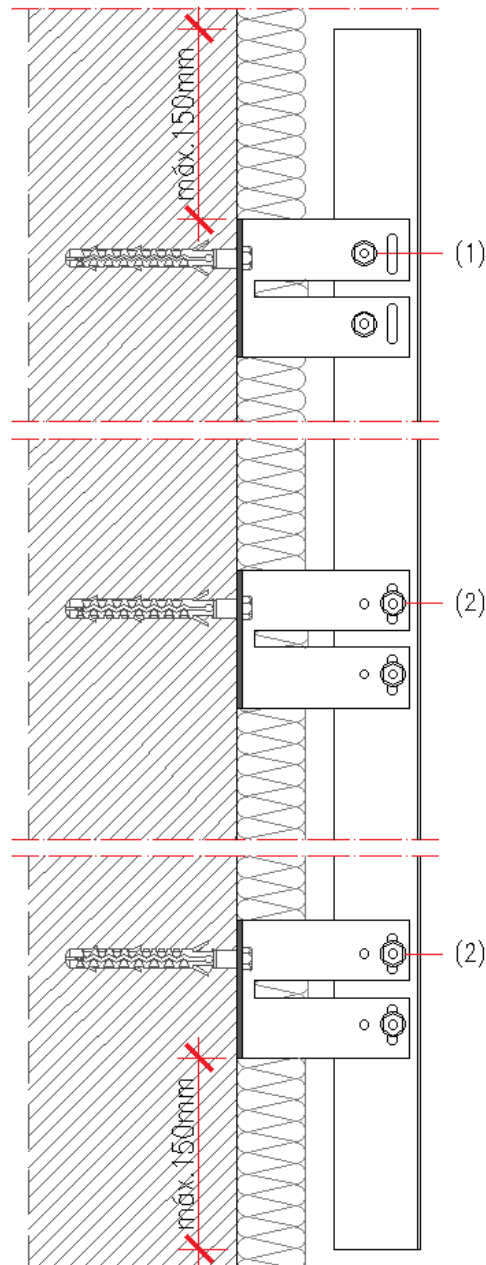

Figure 2.2.4 - Fixing the aluminium profiles to the supporting squares



- (1) Fixed Support;
- (2) Dilatable support.

Figure 2.2.5 - Fixing the aluminium profiles to the supporting squares

2.2.03 Thermal cutting of supporting squares

Due to the high coefficient of thermal transmission, the supporting squares can be insulated from the supporting wall with bases for thermal cutting (see figure 2.2.6).

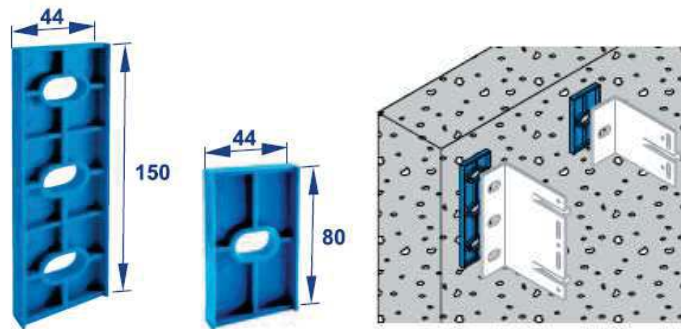

Figure 2.2.6 - Thermal cutting device for supporting squares

2.2.04 Anchors for fixing the supporting squares

The supporting squares are fixed to the support wall using anchors, which can be plastic bushings with a diameter of 10 mm and stainless steel screws with a diameter of 7 mm (see figure 2.2.7).

With regard to the mechanical strength and stability of the anchors, they must be designed and built in such a way that the loads to which they will be subjected during their useful life do not involve one of the following consequences:

- Total or partial breakdown of the structure;
- Deformations that reach unacceptable proportions;
- Damage to other parts of structures, equipment or installations following excessive deformation of the supporting structure;
- Damage of great proportionality to the cause that originated it;

The anchorages must withstand shear loads, tensile loads and a combination of both during the expected service life of the structure, ensuring:

- Adequate resistance to failure (Ultimate Strength Limits);
- Adequate resistance to displacement (Serviceability Limit States).

Anchorage must have an ETA (European Technical Assessment) certification with CE marking or, alternatively, a DH (Document of Homologation) containing the characteristic strength values and the respective security coefficients.

For anchorages that do not have any type of ETA or DH certification, the resistance values must be proven through technical documents or by carrying out load tests.

Metal bushings are generally suitable for concrete supports. Plastic bushings with metal screws are suitable for concrete supports and masonry with solid or hollow elements.



Figure 2.2.7 - Plastic anchor Ø10 mm

Ø7mm stainless steel screw, minimum length 75 mm

Hilti frame assembly video

<https://youtu.be/029BOB609wo?si=5XR2M80bEveAjih0>

2.2.05 Bushings for fixing thermal insulation

The thermal insulation is dimensioned in accordance with the thermal conditioning rules of the Regulation on the Thermal Behaviour Characteristics of Buildings (RCCTE).

It is fixed to the support using plastic bushings or similar material, normally with a wide head and the appropriate length for the thickness of the insulation (see figure 2.2.8).



Figure 2.2.8 - Bushing fixing the thermal insulation to the support structure

2.2.06 Rail profile arranged horizontally to support the clamps

The rail profiles are arranged horizontally and fixed to the primary structure using self-drilling A2 stainless steel screws with a diameter of 5.5, at the rate of two screws for each intersection. The alloy that constitutes these profiles is of class 6060 T6 or higher according to EN 755-2 (see figures 2.2.9 and 2.2.10).



Figure 2.2.9 - Rail profile for supporting the clamps



Figure 2.2.10 - Stainless steel screw 5.5x25, for fixing the rail profile

2.2.07 Clamps

The clamps are the elements fixed to the back of the panel that rest on the C-shaped rail profile arranged horizontally. There are 3 types of clamps: standard, fixed and adjustable. All panels use the 3 types of clamps.

See figures 2.2.11, 2.2.12 and 2.2.13.

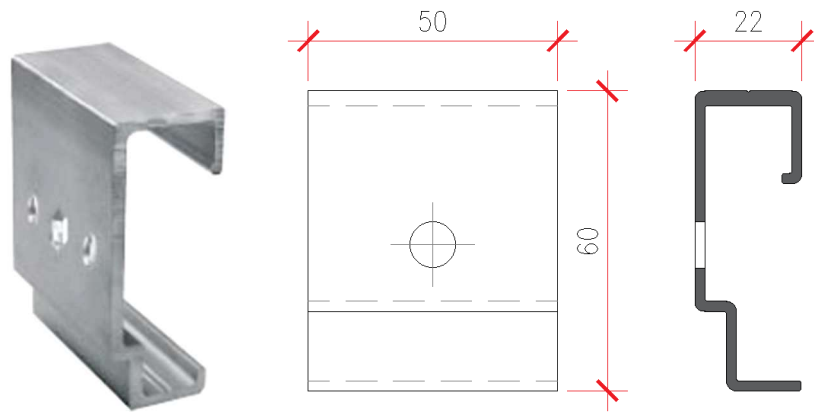

Figure 2.2.11 - Standard clamp

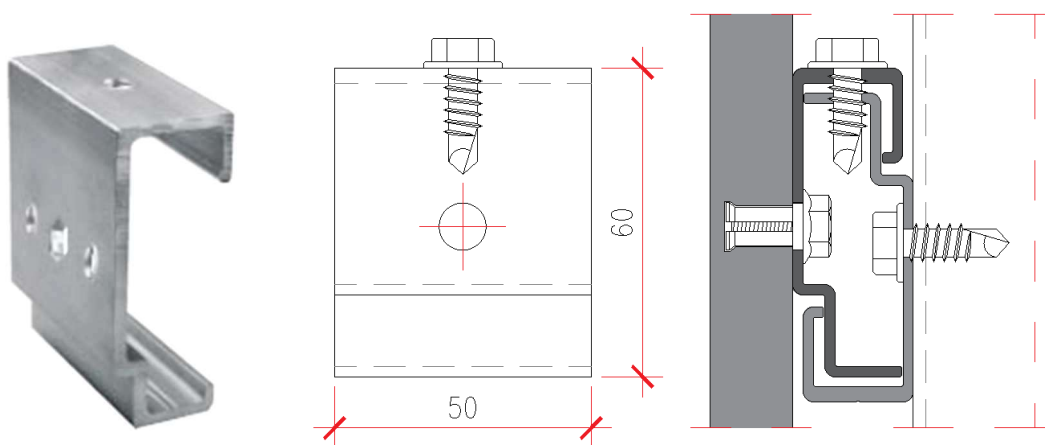

Figure 2.2.12 - Fixed clamp

The screw shown in figure 2.2.10 can be used to block movement.

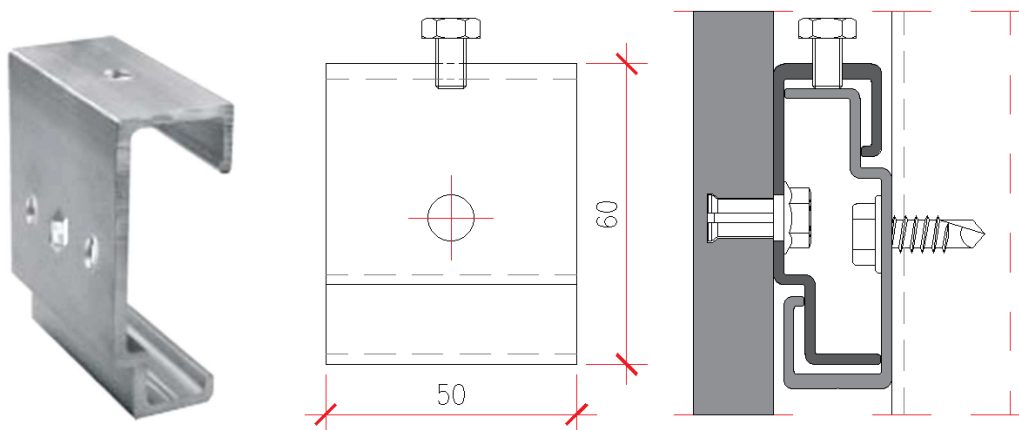

Figure 2.2.13 - Adjustable clamp, same as fixed clamp with metric screw for adjustment

2.2.08 KARL system anchoring

The KARL® Undercut Anchor KH AA is manufactured by KEIL and is suitable for Viroc panels.

The clamps are fixed to the back of the panels using these anchors (see figure 2.2.14).

Viroc panel thickness	Anchoring	Screw
12 mm	KARL type AA hs=8.5	M6x11.5 Ds=14
16 mm	KARL type AA hs=10	M6x13 Ds=14



Figure 2.2.14 - KARL type AA anchor

The value of the characteristic pull-out resistance (Pk) of KARL anchors is:

Viroc panel thickness	Anchoring	Characteristic value Pk
12 mm	KARL hs=8.5	1170 N
16 mm	KARL hs=10	1370 N

2.2.09 Recommended thicknesses of the Viroc façade panels and their tolerances

Thickness: 12 mm \pm 1.0 mm; 16 mm \pm 1.2 mm

See the Viroc panel technical data file for the range of thicknesses and colours available.

Note: Not all colours are produced as standard in the 16 mm thickness.

2.2.10 Panel weight

12 mm: 16.2 \pm 1.2 kg/m²;

16 mm: 21.6 \pm 1.6 kg/m².

2.2.11 Maximum format for the façade panels

The maximum recommended size is 1500x1250 mm.

Larger dimensions may be used. Please note that larger panels are more difficult to install.

Any intermediate dimensions obtained by cutting the panels are possible.

Tolerances: cutting

Length and width: \pm 3 mm

Squareness: \leq 2 mm/m

Edge straightness: \leq 1.5 mm/m

2.2.12 Minimum format for the façade panels

The minimum size of the panel to be applied to a ventilated façade is 300 mm.

Viroc Portugal does not recommend that the ratio between the length and width of the panel exceeds 3 ($L/B \leq 3$).

A panel that is too long and narrow tends to break easily.

2.2.13 Façade assembly operations

A façade is installed as follows:

- a. Marking and identification of the façade elements;
- b. Mounting the supporting squares;
- c. Installation of thermal insulation;
- d. Assembly of the support profiles/mounts arranged vertically;
- e. Mounting the rail profile horizontally;
- f. Varnishing of Viroc panels on both sides and tops;
- g. KARL system anchors;
- h. Fixing the clamps to the back of the panel;
- i. The panels are fixed by snapping onto the rail profiles;
- j. Treatment of singular points.

2.2.14 Marking and identification of façade elements

There is no preferred assembly orientation. The system allows the assembly of all sizes and formats of intermediate dimensions. Viroc panels can be placed horizontally or vertically.

The aim is to follow the stereotomy defined by the architectural project.

2.2.15 Mounting the supporting squares

The location of these elements determines the final position of the support profiles, so they must be positioned precisely.

2.2.16 Fixing the supporting squares to the supporting wall

The supporting squares are fixed to the support wall using anchors made up of plastic bushing with a diameter of 10 mm and metal screws with a diameter of 7 mm.

2.2.17 Fitting the thermal insulation

The thermal insulation is dimensioned in accordance with the thermal conditioning rules of the Regulation on the Thermal Behaviour Characteristics of Buildings (RCCTE).

It is fixed to the support using plastic bushing plugs or similar material, normally with a wide head and the appropriate length for the thickness of the insulation.

2.2.18 Mounting the support profiles

The support profiles are arranged vertically in accordance with the specifications and technical drawings presented in this document, duly adapted to the stereotomy of the architectural project.

The maximum distance between profiles/mounts is 1.2 m. The alignment of the uprights must be checked between adjacent elements and must not differ by more than 2 mm.

2.2.19 Fixing the profiles to the supporting squares

Due to the high expansion coefficient of aluminium profiles, the structure must be designed in such a way as to allow the upright profiles to expand.

The fixed connections are made with 2 screws/rivets placed in the circular bolt holes, blocking movement, and located at the top of the profiles.

The expandable connections are made using 2 screws/rivets placed in the vertically oval shaped bolt holes. The connection can be made with $\text{Ø} \geq 5.5$ mm stainless steel self-drilling screws or $\text{Ø} \geq 4.8$ mm rivets (see figure 2.2.15).



Figure 2.2.15 - Primary structure fixed with supporting squares to the support

2.2.20 Fixing the rail profiles horizontally

The rail profiles are C-shaped, arranged horizontally and fixed to the vertical profiles using two 5.5x25 self-drilling screws at each intersection. They are arranged with a maximum distance between them of 600 mm and in such a way that the clamps anchored to the back of the Viroc panels support them correctly. Its location must not have an error of more than 2 mm (see figure 2.2.16).



Figure 2.2.16 - View of the rail profile arranged horizontally

2.2.21 Cutting Viroc panels

Cuts to be made in Viroc panels should be made using a portable circular saw with suitable cutting blades. The cutting edges of the disk must be made of hard metal, usually tungsten carbide inserts (see figure 2.2.17).



Figure 2.2.17 - Circular saw with tungsten cutting disc

2.2.22 Drilling Viroc panels

To drive the anchors into the back of the panel, the KARL system has drills with stops to drill the panel to the correct depth (see figure 2.2.18). The drill must be in drill mode, without impact.



Figure 2.2.18 - KARL system stopper hole

2.2.23 Surface preparation of Viroc panels

Viroc panels are supplied raw and unfinished. The surfaces show some irregularities and imperfections, such as small incrustations, stains, scratches, small wood chips and salts from chemical reactions.

Before a finishing varnish is applied, the surfaces must be completely clean and dry, with no grease, dust or surface salts. The surfaces that will be visible should be cleaned/polished with an abrasive cleaning disk or alternatively the surface can be sanded with fine 120 grit sandpaper or higher.

Cleaning/polishing does not alter the natural appearance of the panel; it maintains the stains and heterogeneities that characterise it, as well as some salts and incrustations that are embedded in the surface.

The link below shows a video screening how Viroc panels are polished.

<https://www.youtube.com/watch?v=HeQZNVNOZYI>

2.2.24 Varnishing or painting Viroc panels

When used on ventilated façade, Viroc panels must be varnished. Exceptionally, they can be applied without varnish or paint if they are installed under the conditions described in Chapter 2.3.

The purpose of applying varnish to the Viroc panel is to protect it from the aggressions of the environment in which it is located, such as exposure to sunlight and bad weather, increasing its durability, making it easier to clean and maintaining its appearance over time. The application of a varnish changes the tone of the natural colour of the Viroc panel, giving it a "wet" appearance with some shine. After drying, the wet look is softened.

There are no specific paints or varnishes to be applied to Viroc panels. The panel has a surface alkalinity (PH) of 11 to 13, so paints and varnishes suitable for concrete and wood surfaces at the same time are usually the best when applied to a Viroc panel. Paints and varnishes made from acrylic resins or aliphatic polyurethane resins are suitable as they do not yellow on

exposure to UV rays. Solvent-based varnishes are the ones that have shown the best performance, but water-based varnishes are the ones that least alter the original colour of the panel.

Generally speaking, varnishes are easy to apply, but it is very important to bear in mind that the application must be continuous and constant, to ensure that the finish is homogeneous on the panel and that the surface does not become stained and have different shades. The panels must always be painted/varnished on both sides and tops, and the application procedures, supplied by the respective manufacturers, must always be followed for the recommended coats.

The application of paints and varnishes, when carried out on site, should be in a dry, clean place away from the sunlight.

2.2.25 Fixing the clamps to the Viroc panels

The clamps are fixed to the back of the panel by tightening the screws attached to the KARL anchors manufactured by KEIL, which are driven into the panel.

The KARL System has the right tools for setting the anchors (see figure 2.2.19).

Link to visualisation of the anchors in the panel.

<https://youtu.be/DSHI3ObnOfY>

<https://youtu.be/Znhp-D9RsZc>



Figure 2.2.19 - Tool for driving the anchors into the Viroc panel

2.2.26 Panel installation

After the clamps have been attached to the back of the panels, they are fitted into the C-shaped rail profile.

Assembly is carried out from the bottom up, so that the clamps on the top of the panels can be accessed.

Two of the end clamps must be adjustable clamps, so that the levelling of the structure can be corrected. A self-tapping screw will be placed in one of the clamps to block movement (fixed clamp).

Figures 2.2.20 and 2.2.21 show the location of the clamps and their type.

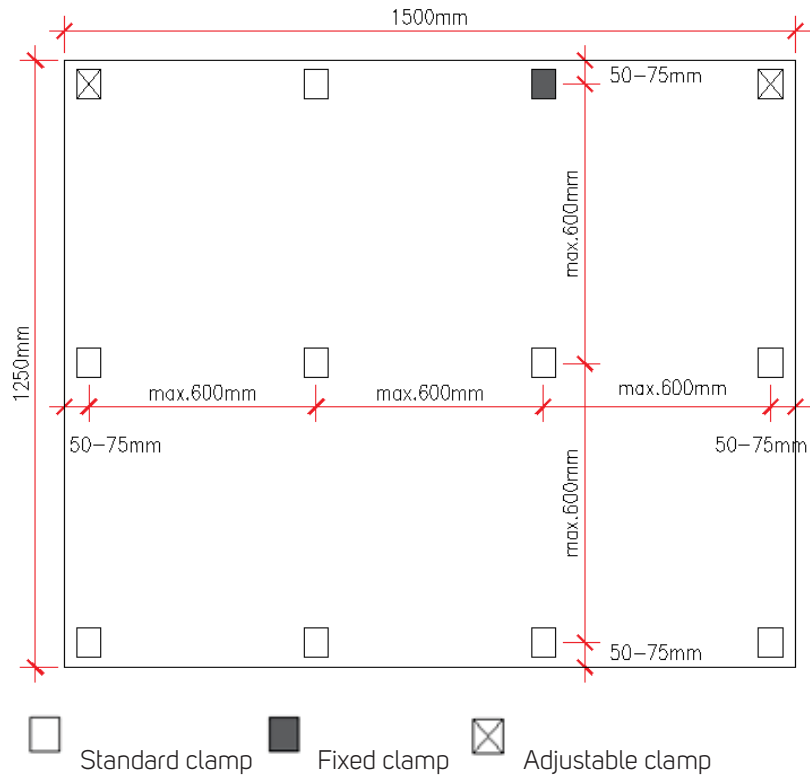

Figure 2.2.20 - Location of clamps, panel arranged horizontally

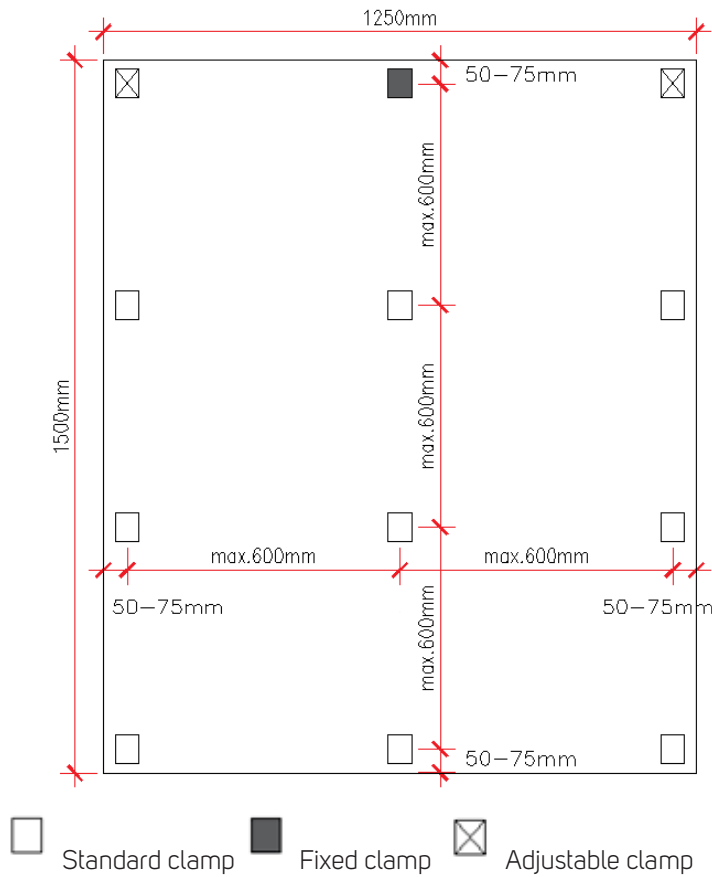

Figure 2.2.21 - Location of clamps, panel arranged vertically

2.2.27 Joints between panels

Viroc panels are installed so that the joints between the panels, both vertical and horizontal, have a gap of between 5 and 8 mm.

2.2.28 Air foil ventilation

The ventilated façade, as recommended in this Technical File, forms a continuous sheet of air between the back of the panel and the thermal insulation.

The minimum opening for ventilation of the air foil is 20 mm thick. This distance must be respected even in areas where there may be obstructions.

At the base of the façade, the opening must be protected by a grille or perforated plate to prevent birds or rodents from entering (see figure 2.2.22).



Figure 2.2.22 - Perforated anti-rodent profile

At the top of the façade, the opening is protected by a ruffle to prevent water from entering directly into the air gap.

The air gap must be partitioned, both vertically and horizontally, without impeding the free circulation of air.

The purpose of this compartmentalisation is to prevent fire from spreading between different floors or elevations in the event of a fire.

The air gap can be partitioned using galvanised steel or aluminium sheeting. See general details.

Detailed drawings of these areas are presented in chapter 2.2.35.

2.2.29 Angle profiles

Some manufacturers of accessory elements for façade have auxiliary profiles for finishing the corners of the façade. The use of these profiles is optional (see figures 2.2.23 and 2.2.24).



Figure 2.2.23 - Corner angle profiles



Figure 2.2.24 - Corner angle profiles

2.2.30 Cleaning the panels after application

The panels can be cleaned using a jet of water with neutral detergent.

2.2.31 Replacing a panel

To replace a façade panel, the existing panel must first be removed.

Since the panels are rigidly fixed to one of the clamps on the top of the panels, it is necessary to access the upper area of the panel to be replaced in order to loosen the screw that locks the panel in place.

2.2.32 Impact resistance

Hard Body Impact Energy EN 1128

12 mm, E = 12.9 Joules, Burst Energy

16 mm, E = 12.8 Joules, Burst Energy

Impact test according to ETAG 034

12 mm thick panel

Type of Impact	Energy	Results
Hard Body	1 J	No damage (Pass)
	3 J	No damage (Pass)
Soft Body	20 J	No damage (Pass)
	60 J	No damage (Pass)
	100 J	No damage (Pass)
	130 J	No damage (Pass)
	300 J	Fail

2.2.33 Wind action

Exposure to wind action perpendicular to the plane of the panel corresponds to a pressure or depression (in kN/m^2), which resistance design values are shown in Tables 1 to 5.

The wind resistance load tables were drawn up on the basis of pull-out tests on KARL anchors, resulting from experimental tests and obtained with a security coefficient of 3.5.

Wind loads are quantified in accordance with the National Annex of Eurocode 1 (RSA).

2.2.34 Example of Safety check of a Viroc panel to wind loads

For a 12 mm thick Viroc panel with the configuration shown below, what is the maximum permissible wind load?

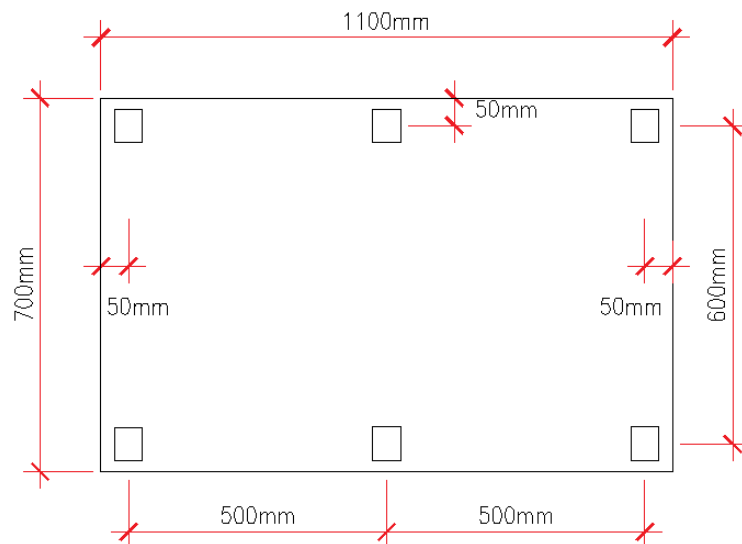

Configuration: 3x2, horizontal distance 500 mm and vertical distance 600 mm.

Using Table 3

Horizontal distance between screws 500 mm (20")											
Thickness of panel	(H x V)	Vertical distance between screws									
		300 mm	12"	400 mm	16"	500 mm	20"	600 mm	24"	700 mm	28"
		kN/m2	psf	kN/m2	psf	kN/m2	psf	kN/m2	psf	kN/m2	psf
12 mm 1/2"	2 x 2	2,0	42	2,0	42	2,0	42	1,4	29	1,0	21
	2 x N	2,0	42	2,0	42	1,8	37	1,5	31	1,3	27
	N x 2	2,7	56	2,1	45	1,8	37	1,4	29	1,0	21
	N x N	1,4	30	1,1	22	0,9	18	0,7	15	0,6	13
16 mm 5/8"	2 x 2	3,2	66	3,2	66	3,2	66	2,2	46	1,6	34
	2 x N	3,2	66	2,6	55	2,1	44	1,7	36	1,5	31
	N x 2	3,1	65	2,5	52	2,1	44	1,8	37	1,6	33
	N x N	1,7	35	1,3	26	1,0	21	0,8	17	0,7	15

Table 3 - Permissible pressure, 500 mm spacing between horizontal fixings

The design value for the resistance of the Viroc panel to wind pressure (w_{rd}) is 1.4 KN/m² (29 psf).

Note: The action of the wind exerts a pressure or depression on the panel. This is a constraint when it acts as a depression, since the panel is fixed only by the anchor and breakage occurs by cutting/punching the panel in these areas.

2.2.35 Details

Figures 2.2.25 to 2.2.38 show examples of various details and unique areas of the façade.

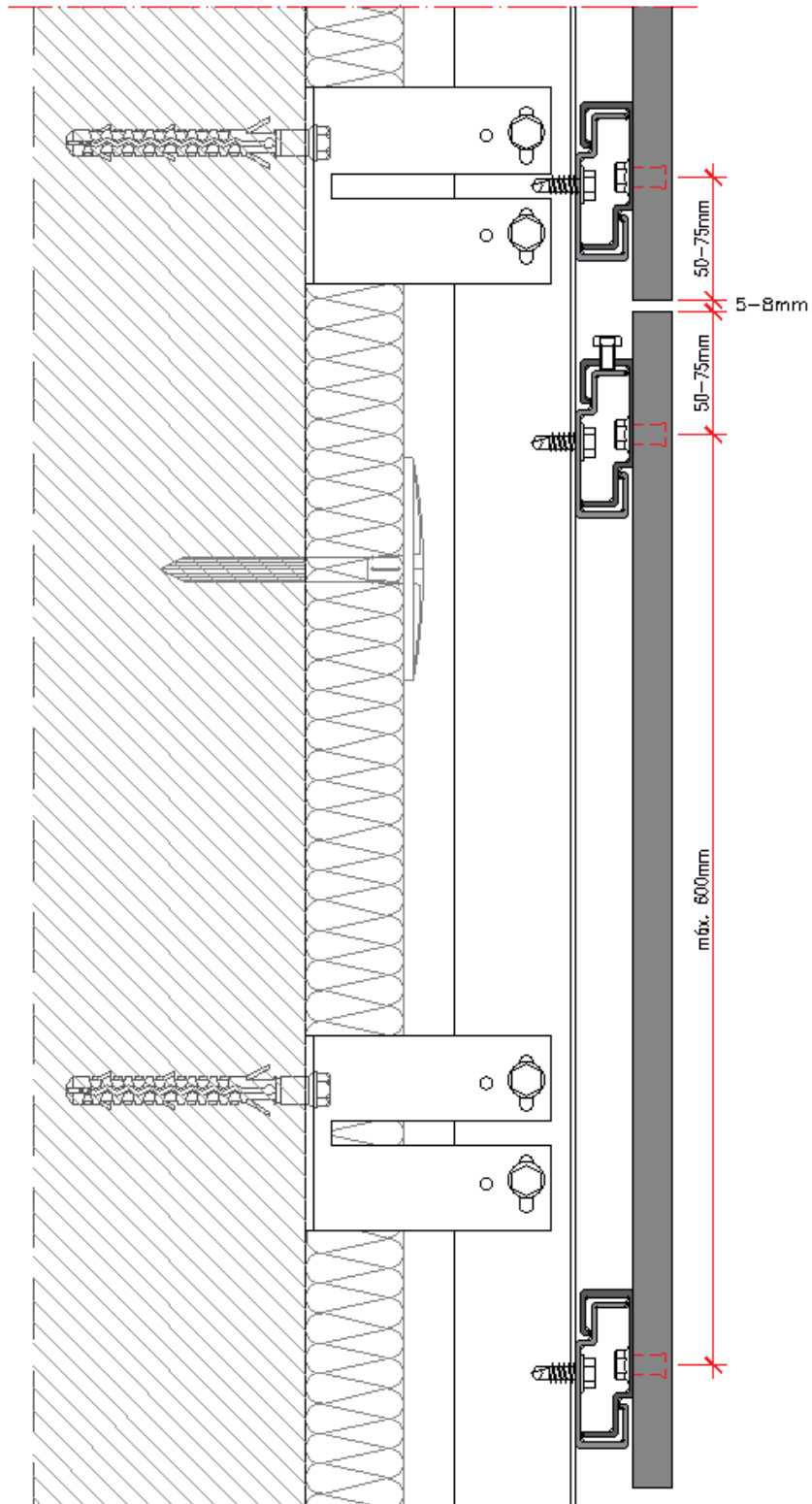

Figure 2.2.25 - Vertical section

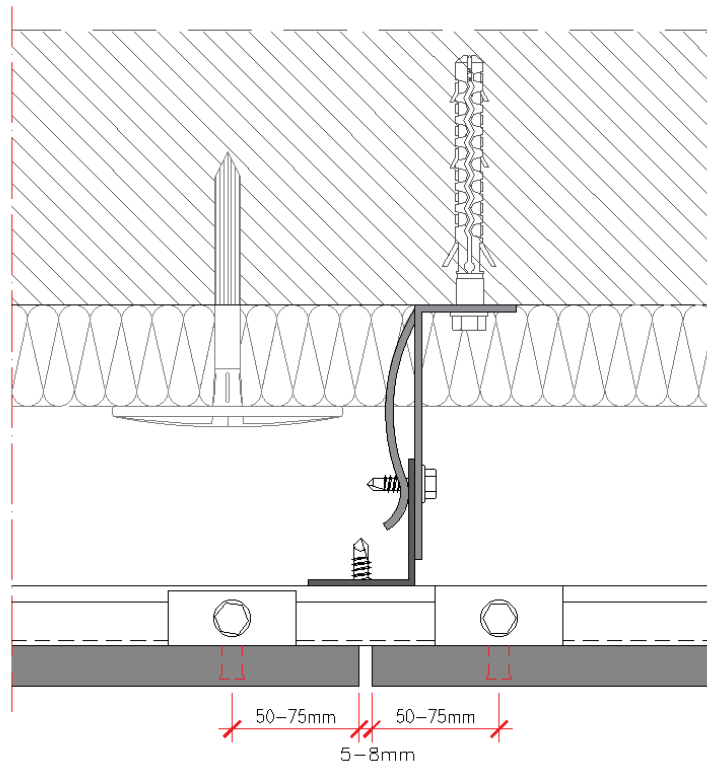

Figure 2.2.26 - Horizontal section

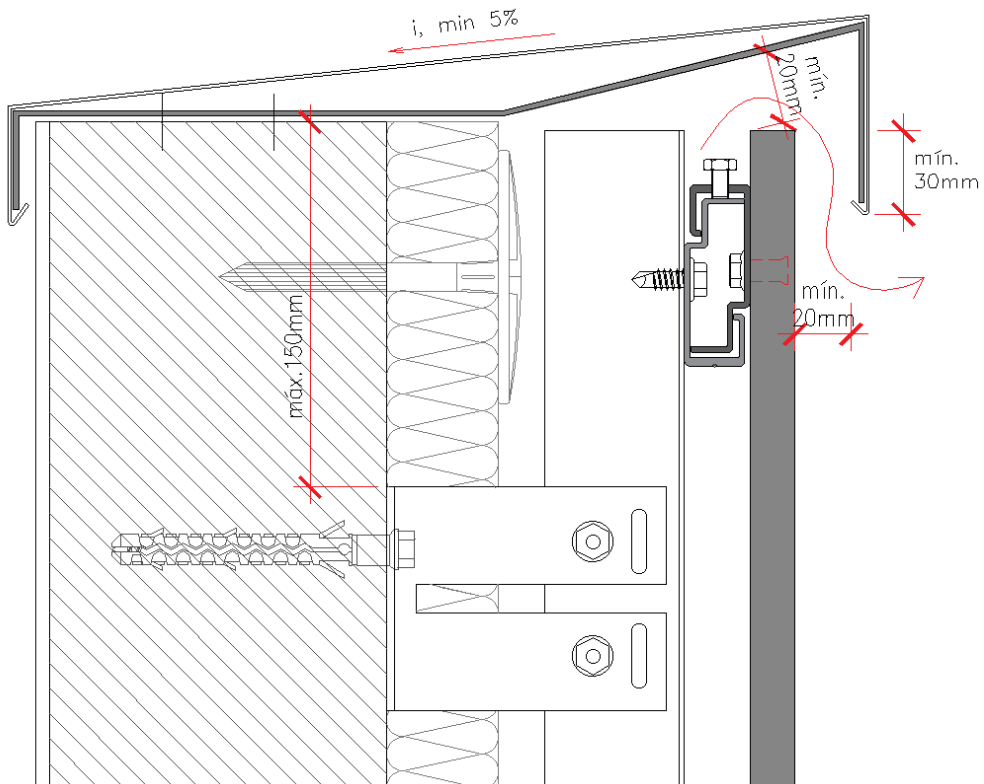

Figure 2.2.27 - Detail of the top trim

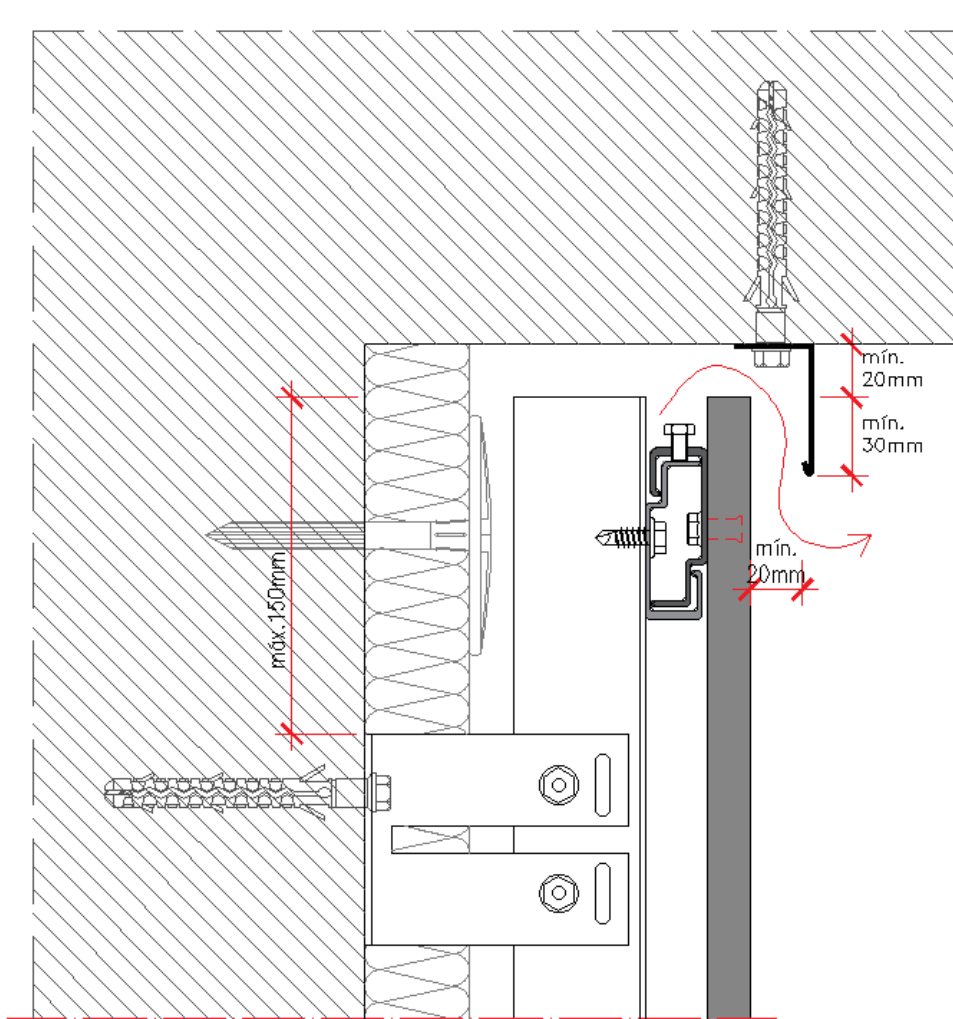
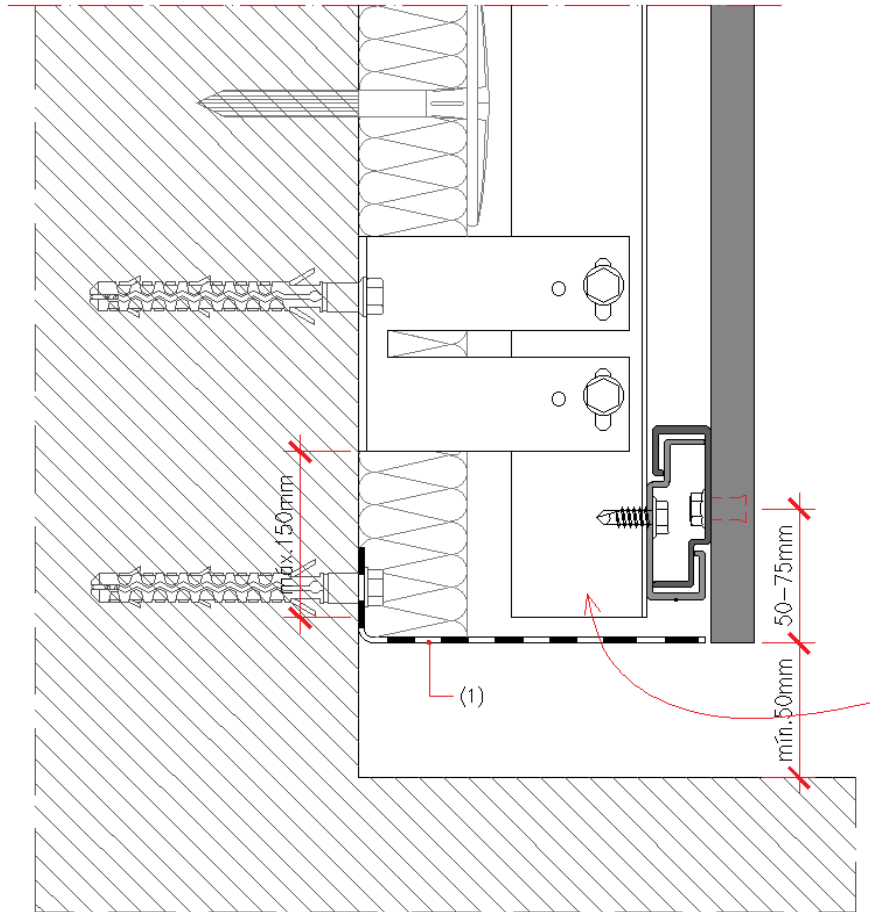
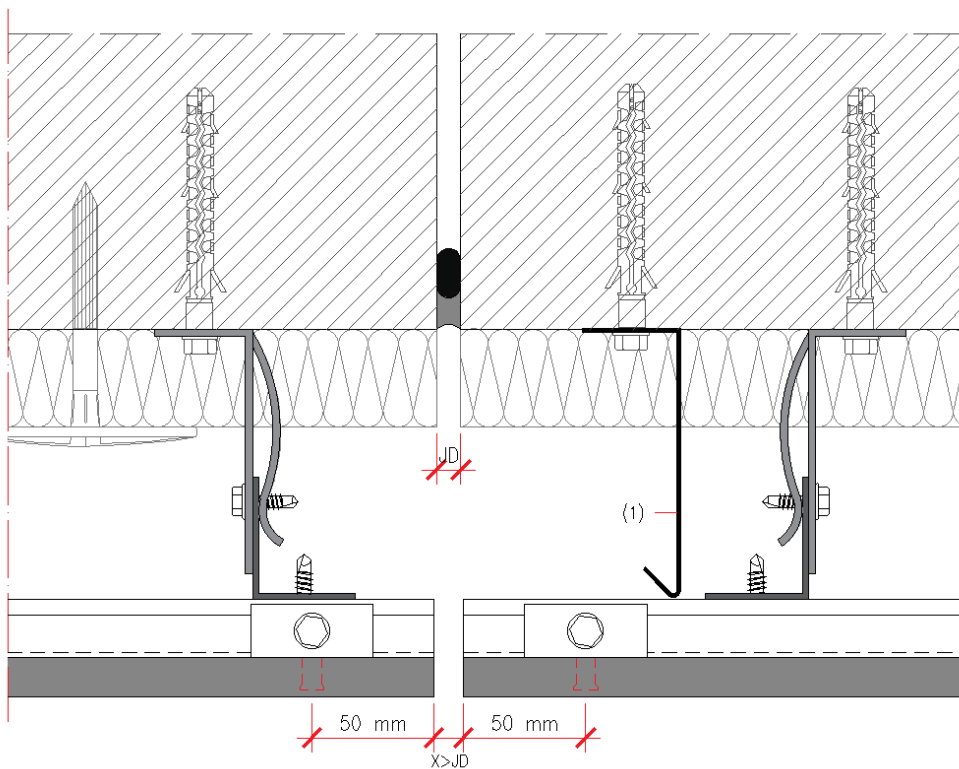

Figure 2.2.28 - Detail of the balcony finish



(1) Anti-rodent grille

Figure 2.2.29 - Detail of base



(1) Compartmentalisation of the air foil

Figure 2.2.30 - Detail of expansion joint

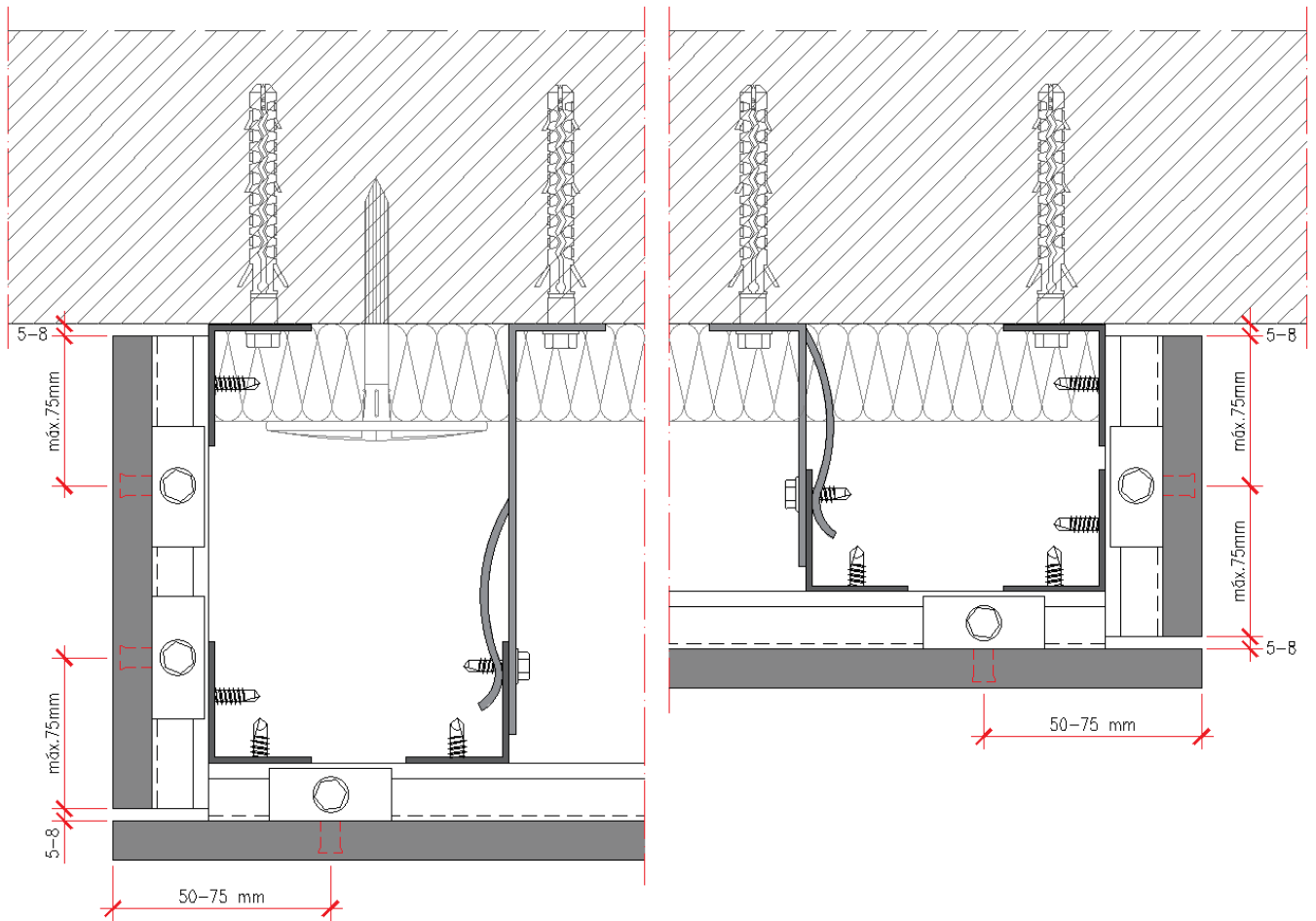
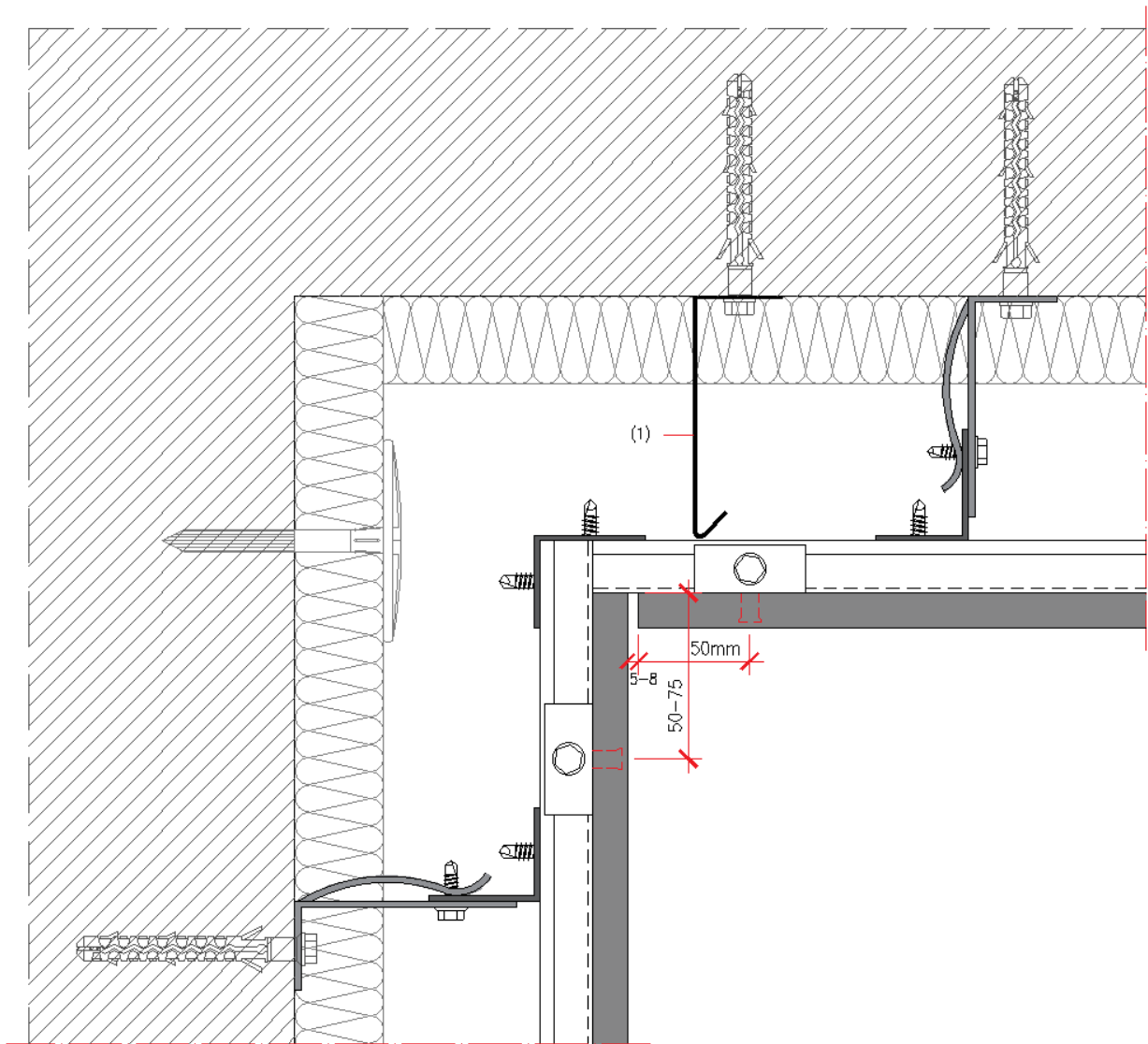
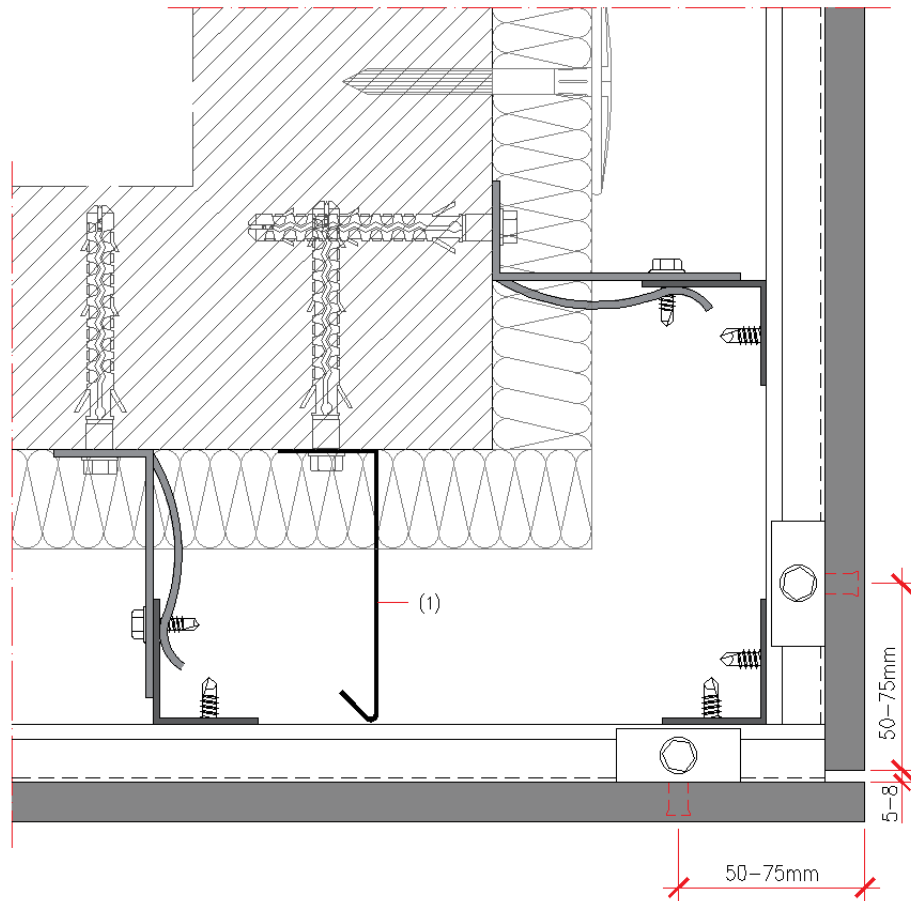

Figure 2.2.31 - Detail of side trim



(1) Compartmentalisation of the air foil

Figure 2.2.32 - Detail of corner angle



(1) Compartmentalisation of the air foil

Figure 2.2.33 - Detail of the corner angle

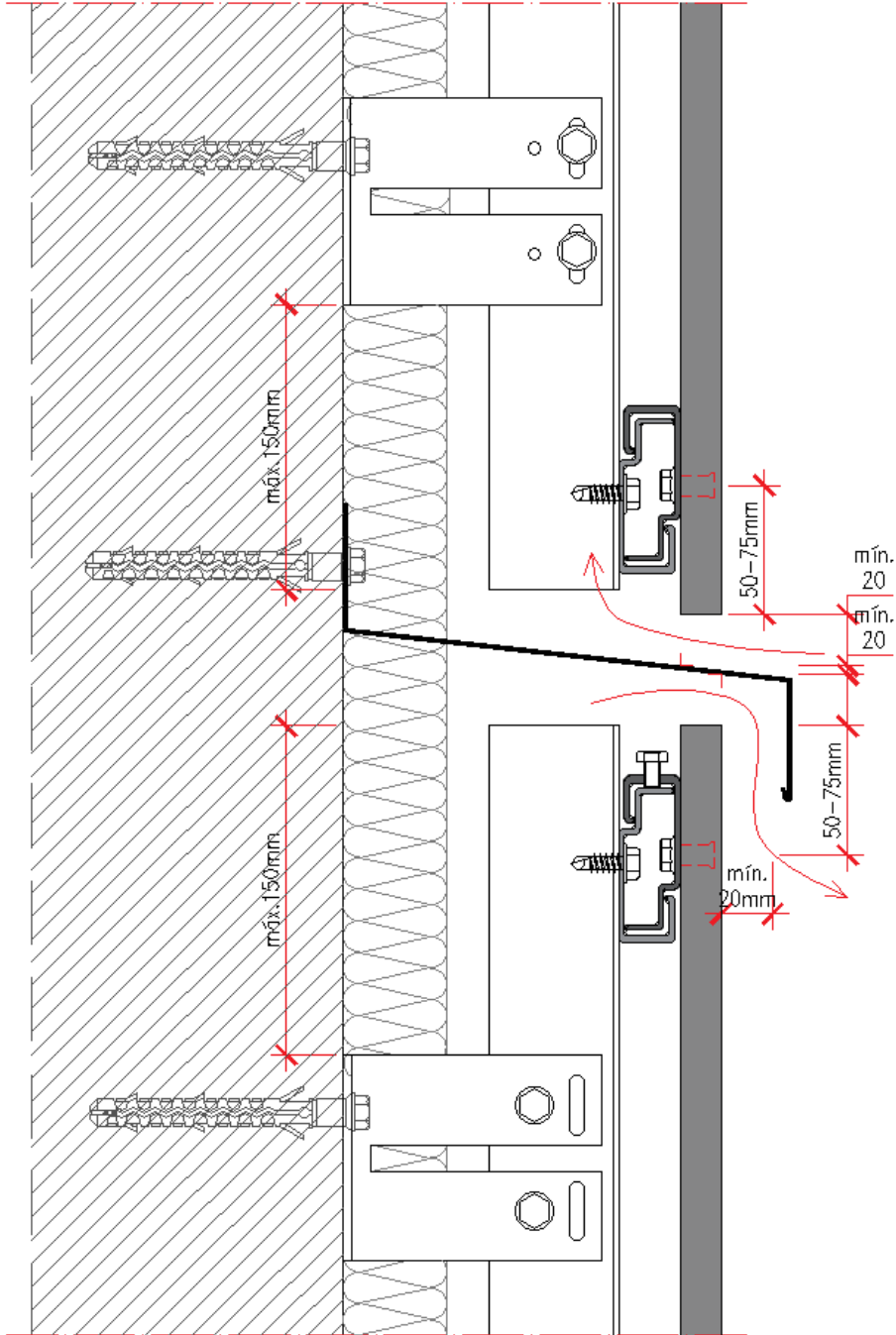

Figure 2.2.34 - Horizontal compartmentalization of the air foil

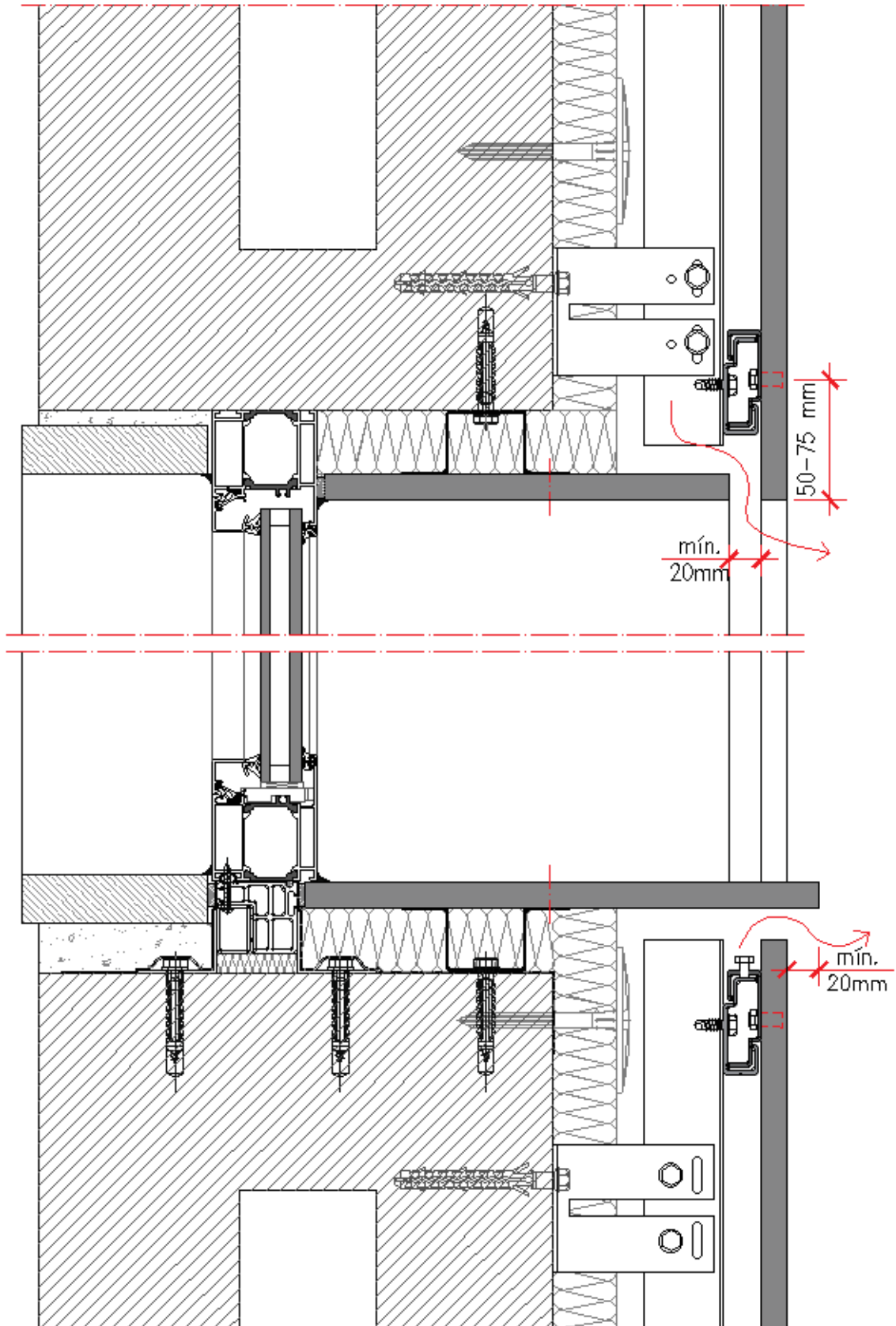

Figure 2.2.35 - Detail of window opening, vertical section

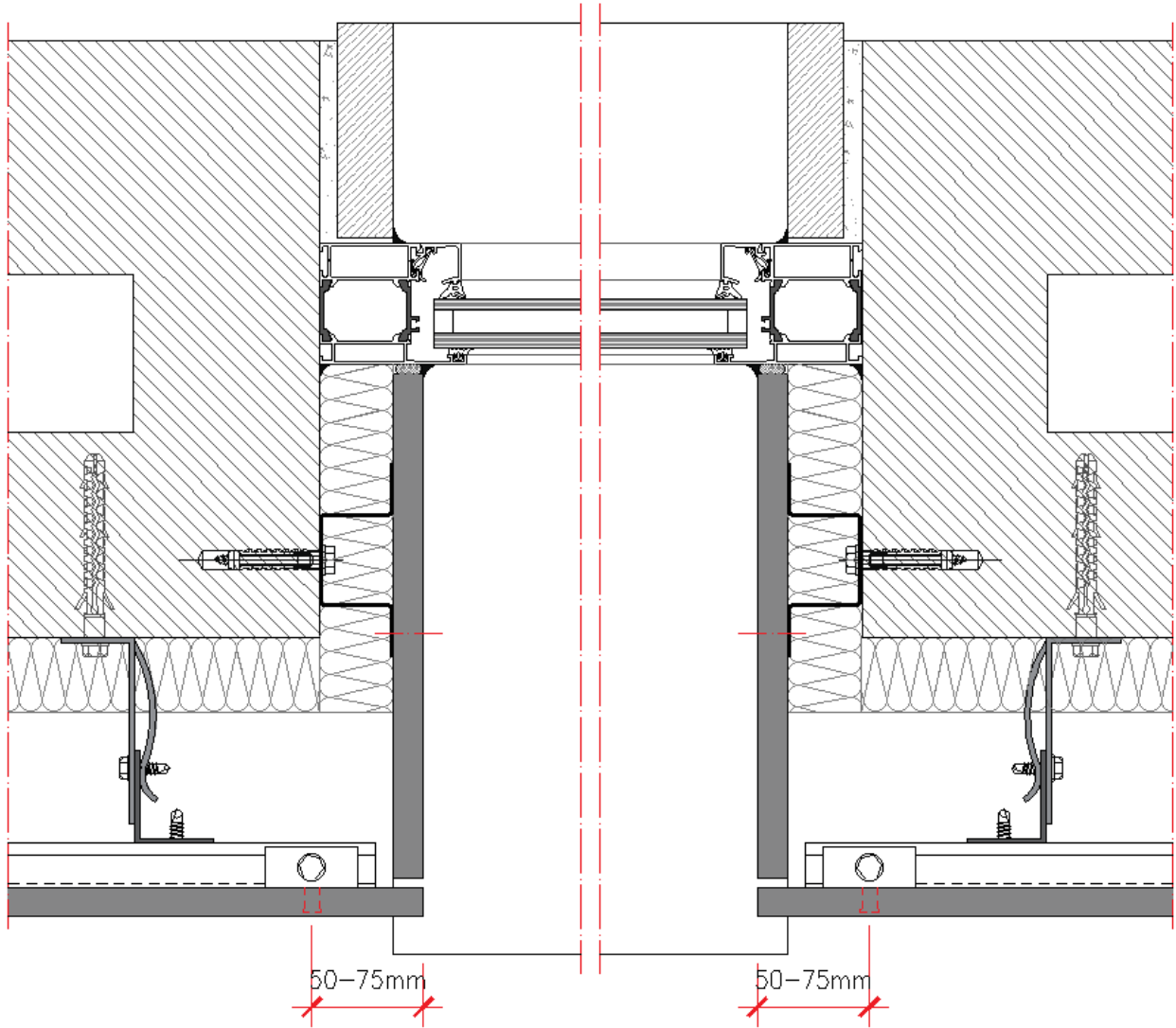

Figure 2.2.36 - Detail of window opening, horizontal section

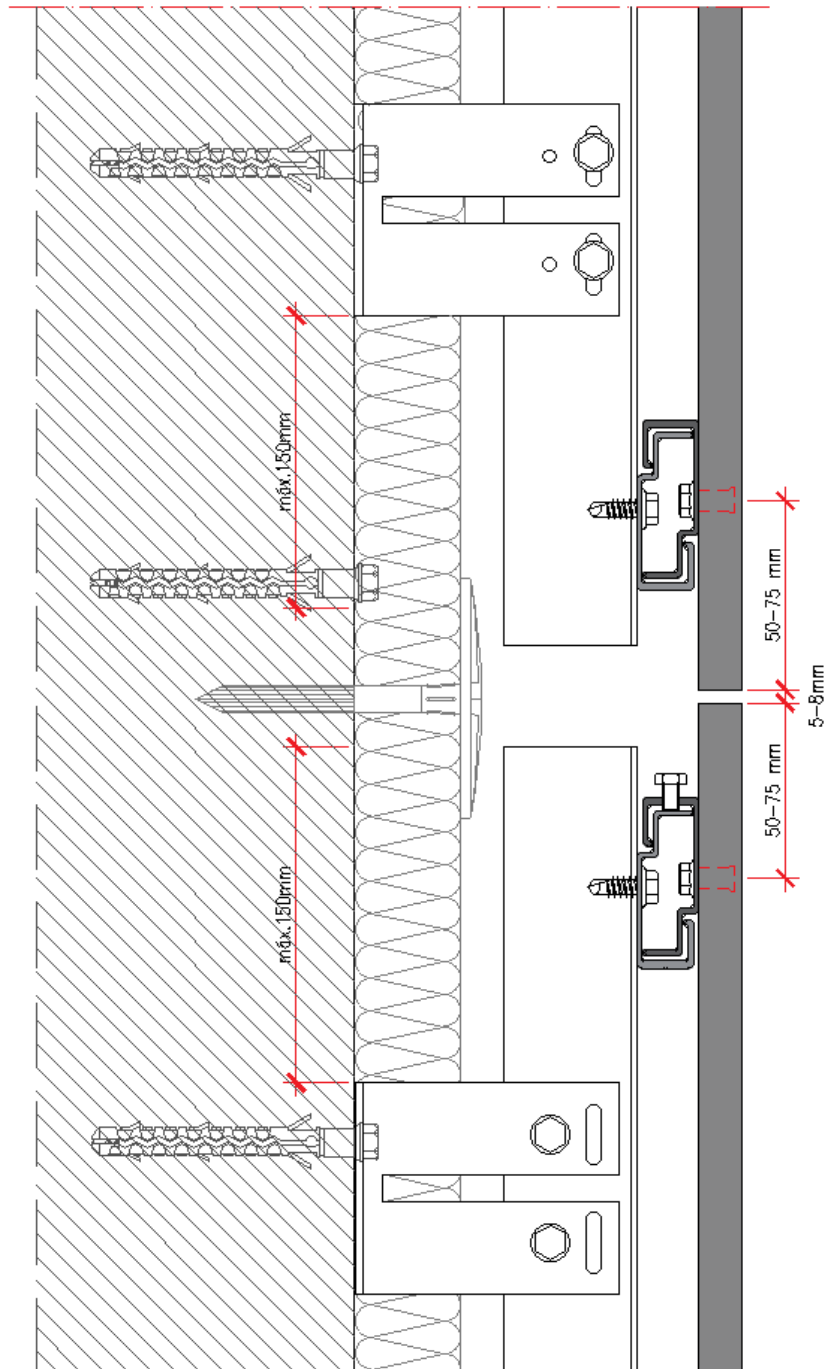
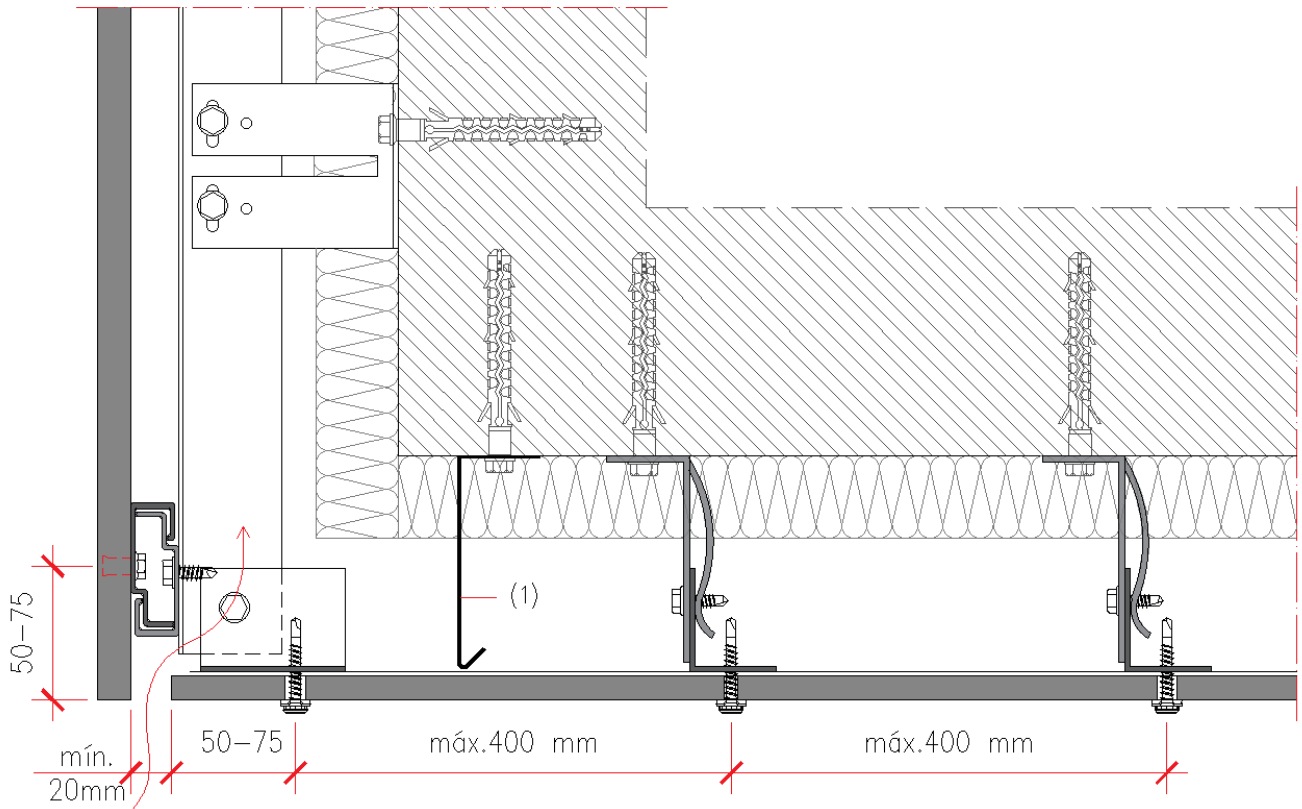

Figure 2.2.37 - Fractionation of the structure



(1) Compartmentalization of the air foil

Figure 2.2.38 - Detail of Façade-Tiling connection

TABLES

Wind load table

Façade system with concealed mechanical fixing

Maximum pressure on panels when subjected to wind action (suction)

H number of screws arranged horizontally

V number of screws arranged vertically

$N \geq 3$

Horizontal distance between screws 300 mm (12")											
Thickness of panel	(H x V)	Vertical distance between screws									
		300 mm kN/m2	12" psf	400 mm kN/m2	16" psf	500 mm kN/m2	20" psf	600 mm kN/m2	24" psf	700 mm kN/m2	28" psf
12 mm 1/2"	2 x 2	5,5	116	3,1	65	2,0	42	1,4	29	1,0	21
	2 x N	4,5	93	3,3	70	2,7	56	2,2	47	1,9	40
	N x 2	4,5	93	3,1	65	2,0	42	1,4	29	1,0	21
	N x N	2,4	50	1,8	37	1,4	30	1,2	25	1,0	21
16 mm 5/8"	2 x 2	9,8	204	7,4	154	4,7	99	3,3	69	2,4	50
	2 x N	5,2	109	3,9	82	3,1	65	2,6	55	2,2	47
	N x 2	5,2	109	4,2	87	3,5	73	3,0	62	2,4	50
	N x N	2,8	58	2,1	44	1,7	35	1,4	29	1,2	25

Table 1 - Maximum pressure, 300 mm spacing between horizontal fixings

Horizontal distance between screws 400 mm (16")											
Thickness of panel	(H x V)	Vertical distance between screws									
		300 mm kN/m2	12" psf	400 mm kN/m2	16" psf	500 mm kN/m2	20" psf	600 mm kN/m2	24" psf	700 mm kN/m2	28" psf
12 mm 1/2"	2 x 2	3,1	65	3,1	65	2,0	42	1,4	29	1,0	21
	2 x N	3,1	65	2,7	56	2,1	45	1,8	37	1,5	32
	N x 2	3,3	70	2,7	56	2,0	42	1,4	29	1,0	21
	N x N	1,8	37	1,3	28	1,1	22	0,9	19	0,8	16
16 mm 5/8"	2 x 2	4,9	103	4,9	103	3,2	66	2,2	46	1,6	34
	2 x N	4,2	87	3,1	65	2,5	52	2,1	44	1,8	37
	N x 2	3,9	82	3,1	65	2,6	55	2,2	46	1,6	34
	N x N	2,1	44	1,6	33	1,3	26	1,0	22	0,9	19

Table 2 - Maximum pressure, 400 mm spacing between horizontal fixings

Horizontal distance between screws 500 mm (20")											
Thickness of panel	(H x V)	Vertical distance between screws									
		300 mm	12"	400 mm	16"	500 mm	20"	600 mm	24"	700 mm	28"
		kN/m2	psf	kN/m2	psf	kN/m2	psf	kN/m2	psf	kN/m2	psf
12 mm 1/2"	2 x 2	2,0	42	2,0	42	2,0	42	1,4	29	1,0	21
	2 x N	2,0	42	2,0	42	1,8	37	1,5	31	1,3	27
	N x 2	2,7	56	2,1	45	1,8	37	1,4	29	1,0	21
	N x N	1,4	30	1,1	22	0,9	18	0,7	15	0,6	13
16 mm 5/8"	2 x 2	3,2	66	3,2	66	3,2	66	2,2	46	1,6	34
	2 x N	3,2	66	2,6	55	2,1	44	1,7	36	1,5	31
	N x 2	3,1	65	2,5	52	2,1	44	1,8	37	1,6	33
	N x N	1,7	35	1,3	26	1,0	21	0,8	17	0,7	15

Table 3 - Maximum pressure, 500 mm spacing between horizontal fixings

Horizontal distance between screws 600 mm (24")											
Thickness of panel	(H x V)	Vertical distance between screws									
		300 mm	12"	400 mm	16"	500 mm	20"	600 mm	24"	700 mm	28"
		kN/m2	psf	kN/m2	psf	kN/m2	psf	kN/m2	psf	kN/m2	psf
12 mm 1/2"	2 x 2	1,4	29	1,4	29	1,4	29	1,4	29	1,0	21
	2 x N	1,4	29	1,4	29	1,4	29	1,3	27	1,1	23
	N x 2	2,2	47	1,8	37	1,5	31	1,3	27	1,0	21
	N x N	1,2	25	0,9	19	0,7	15	0,6	12	0,5	11
16 mm 5/8"	2 x 2	2,2	46	2,2	46	2,2	46	2,2	46	1,6	34
	2 x N	2,2	46	2,2	46	1,8	37	1,5	31	1,3	27
	N x 2	2,6	55	2,1	44	1,7	36	1,5	31	1,3	27
	N x N	1,4	29	1,0	22	0,8	17	0,7	15	0,6	12

Table 4 - Maximum pressure, 600 mm spacing between horizontal fixings

Horizontal distance between screws 700 mm (28")											
Thickness of panel	(H x V)	Vertical distance between screws									
		300 mm	12"	400 mm	16"	500 mm	20"	600 mm	24"	700 mm	28"
		kN/m2	psf	kN/m2	psf	kN/m2	psf	kN/m2	psf	kN/m2	psf
12 mm 1/2"	2 x 2	1,0	21	1,0	21	1,0	21	1,0	21	1,0	21
	2 x N	1,0	21	1,0	21	1,0	21	1,0	21	1,0	20
	N x 2	1,9	40	1,5	32	1,3	27	1,1	23	1,0	20
	N x N	1,0	21	0,8	16	0,6	13	0,5	11	0,4	9
16 mm 5/8"	2 x 2	1,6	34	1,6	34	1,6	34	1,6	34	1,6	34
	2 x N	1,6	34	1,6	34	1,6	33	1,3	27	1,1	23
	N x 2	2,2	47	1,8	37	1,5	31	1,3	27	1,1	23
	N x N	1,2	25	0,9	19	0,7	15	0,6	12	0,5	11

Table 5 - Maximum pressure, 700 mm spacing between horizontal fixings



Technical File

Chapter 2 - Façades

2.3 - Panel without varnish or paint

Cement-bonded particleboards

Office

Lisboa Oriente

Av. Infante Dom Henrique 337, 3rd Floor
1800- 210 LISBON, PORTUGAL

Factory

VIROC Portugal S.A.
National Road 10
Km 44.7, Vale da Rosa
2914-519 SETÚBAL, PORTUGAL

In/ investwood

www.investwood.pt



INDEX

2.	VENTILATED FAÇADES	7
2.3	VIROC PANEL ON FAÇADES WITHOUT VARNISHING OR PAINTING	7
2.3.01	Wooden support structure.....	7
2.3.02	Galvanised steel support frame	8
2.3.03	Fixing supporting squares	9
2.3.04	Anchors for fixing the supporting squares.....	10
2.3.05	Bushings for fixing thermal insulation	10
2.3.06	Wooden upright protection strips.....	11
2.3.07	Screws for fixing the panels to a wooden frame.....	11
2.3.08	Screws for fixing the panels supported on a galvanised steel frame.....	12
2.3.09	Rivets for fixing the panels supported on a frame made of galvanised steel.....	13
2.3.10	Recommended thicknesses of Viroc façade panels and their tolerance.....	14
2.3.11	Panel weight.....	14
2.3.12	Viroc panel manufacturing dimensions and cutting tolerances.....	14
2.3.13	Maximum format of panels applied to unvarnished façade	14
2.3.14	Minimum format for façade panels	15
2.3.15	Façade assembly operations.....	15
2.3.16	Marking and identification of façade elements	15
2.3.17	Mounting the supporting squares	15
2.3.18	Fixing supporting squares to the supporting wall	15
2.3.19	Angle plates	15
2.3.20	Fitting the thermal insulation.....	15
2.3.21	Mounting the support profiles.....	16
2.3.22	Fixing the profiles to the supporting squares.....	16
2.3.23	Wooden upright protection strips.....	17
2.3.24	Cutting Viroc panels	17
2.3.25	Drilling Viroc panels	17
2.3.26	Preparing the surface of the Viroc panels	17
2.3.27	Varnishing or painting Viroc panels	18
2.3.28	Fixing Viroc panels	18
2.3.29	Auxiliary assembly tools	20
2.3.30	Treatment of the joints.....	20
2.3.31	Air foil ventilation	21
2.3.32	Angle profiles.....	21
2.3.33	Cleaning the panels after application.....	22
2.3.34	Replacing a panel.....	22
2.3.35	Impact resistance.....	22
2.3.36	Wind action.....	22
2.3.37	Wind safety check.....	23
2.3.38	Example of Safety check of a Viroc panel to wind loads	24
2.3.39	Run-off	25
2.3.40	Surface warping	25
2.3.41	Details, wooden structure	26
2.1.42	Details, galvanised steel frame	35

INDEX TO TABLES AND FIGURES

Figure 2.3.1 - Wooden structure.....	8
Figure 2.3.2 - Galvanised steel profiles.....	9
Figure 2.3.3 - Galvanised steel profiles (Alternative).....	9
Figure 2.3.4 - Galvanised steel supporting squares.....	9
Figure 2.3.5 - Ø10 mm plastic anchor.....	10
Figure 2.3.6 - M8 metal anchor.....	10
Figure 2.3.7 - Bushings for fixing thermal insulation to the support structure.....	11
Figure 2.3.8 - Flexible PVC or EPDM protection strip.....	11
Figure 2.3.9 - Screws for wooden structures.....	12
Figure 2.3.10 - Screws for metal structures.....	13
Figure 2.3.11 - Rivets for fixing Viroc panels to a metal structure.....	14
Figure 2.3.12 - Clamping nozzle, screwed into the riveting tool mouth.....	14
Figure 2.3.13 - Auxiliary angle plate, galvanised steel Z350. Thickness: 2.5 mm.....	15
Figure 2.3.14 - Fixing the wooden uprights to the supporting squares (2 Ø≥6 screws).....	16
Figure 2.3.15 - Fixing the galvanised steel profiles to the supporting squares (Ø≥5.5 screws or Ø≥4.8 rivets).....	16
Figure 2.3.16 - Circular saw with tungsten cutting disc.....	17
Figure 2.3.17 - HSS drill and bits (for drilling metal).....	17
Figure 2.3.18 - Location of fixings and hole diameter.....	18
Figure 2.3.19 - Correct tightening and positioning of the screws.....	19
Figure 2.3.20 - Correct tightening and positioning of the screws.....	19
Figure 2.3.21 - Minimum distance from the screws to the edges of the beams.....	19
Figure 2.3.22 - Correct positioning of screws or rivets.....	20
Figure 2.3.23 - Spanner for centering screws.....	20
Figure 2.3.24 - spanner for bolt hole-centering.....	20
Figure 2.3.25 - Bolt hole-centering tool.....	20
Figure 2.3.26 - Perforated anti-rodent profile.....	21
Figure 2.3.27 - Corner angle profiles.....	21
Figure 2.3.28 - Corner angle profiles.....	22
Table 4 - Allowable pressure, 600 mm spacing between screws horizontally.....	24
Figure 2.3.29 - Vertical section, joint between panels.....	26
Figure 2.3.30 - Horizontal section, joint between panels.....	26
Figure 2.3.31 - Balcony finish.....	27
Figure 2.3.32 - Side finish.....	27
Figure 2.3.33 - JD-Expansion joint.....	28
Figure 2.3.34 - Corner angle.....	28
Figure 2.3.35 - Corner angle.....	29
Figure 2.3.36 - Horizontal compartmentalisation of the air gap.....	29
Figure 2.3.37 - Detail of the base, anti-rodent grid.....	30
Figure 2.3.38 - Horizontal section, window opening.....	30
Figure 2.3.39 - Vertical section, window opening.....	31
Figure 2.3.40 - Detail of the top.....	32
Figure 2.3.41 - Fractionation of the structure: Profiles with length ≤ 6 m.....	32
Figure 2.3.42 - Fractionation of the structure: Profiles with length > 6 m.....	33
Figure 2.3.43 - Detail of the façade - false ceiling connection.....	34
Figure 2.3.44 - Vertical section, joint between panels.....	35
Figure 2.3.45 - Horizontal section, joint between panels.....	35
Figure 2.3.46 - Balcony finish.....	36
Figure 2.3.47 - Side finish.....	36
Figure 2.3.48 - JD-Expansion joint.....	37
Figure 2.3.49 - Corner angle.....	37

Figure 2.3.50 - Corner angle	38
Figure 2.3.51 - Corner angle, variant.....	38
Figure 2.3.52 - Horizontal compartmentalisation of the air gap.....	39
Figure 2.3.53 - Detail of the base, anti-rodent grid	39
Figure 2.3.54 - Horizontal section, window opening	40
Figure 2.3.55 - Detail of the top	40
Figure 2.3.56 - Vertical section, window opening.....	41
Figure 2.3.57 - Fractioning the structure: Profiles with length ≤ 6 m.....	42
Figure 2.3.58 - Fractionation of the structure: Profiles with length > 6 m	42
Figure 2.3.59 - Detail of the façade - false ceiling connection.....	43
WIND LOAD TABLES.....	44
Table 1 - Maximum pressure, 300 mm spacing between screws horizontally.....	44
Table 2 - Maximum pressure, 400 mm spacing between screws horizontally.....	44
Table 3 - Maximum pressure, 500 mm spacing between screws horizontally.....	45
Table 4 - Maximum pressure, 600 mm spacing between screws horizontally.....	45
Table 5 - Maximum pressure, 700 mm spacing between screws horizontally.....	46

Credits

Author

José Pinheiro Soares,

suporte.tecnico@investwood.pt

Review and English Translation

CS Traduções

geral@cstraducoes.pt

Viroc Portugal S.A. reserves the right to modify this document without prior notice.

This Technical File annuls all previous technical documents.

Issue: February 15, 2024



2. VENTILATED FAÇADES

Viroc panels can be used to clad the façade of buildings, forming a panel-ventilated façade.

Viroc panels have a heterogeneous appearance with differences in tone on the same face, between faces of the same panel or between different productions.

Surfaces may be uneven.

With exposure to the sunlight, the colour of the panels changes slightly, becoming lighter. This variation in tone varies from colour to colour.

The panels, when placed outdoors, are subject to dimensional variations of +1.5 mm to -5.0 mm per linear meter when the panel is sealed on both sides and tops. The panel fixing system must allow for this dimensional variation.

Ventilated façades are made up of:

- Viroc panels
- Support structure for the panels and their fixing elements;
- Screws or rivets for fixing the panels to the support structure;
- Thermal insulation;
- Ventilation air layer;
- Complementary profiles for the treatment of singular points.

2.3 VIROC PANEL ON FAÇADES WITHOUT VARNISHING OR PAINTING

In this system, the Viroc panels are applied raw without finishing and fixed to the structure using screws or rivets.

As the panel is not varnished, it will suffer greater dimensional variations, so the maximum panel size allowed is 1500x625 mm.

In order to allow for dimensional variations, without introducing force that could damage the panels, the fixing system must allow for dimensional variation.

For the panel peripheral fixings, the diameter of the holes to be drilled in the panels to install the screws is 10 mm larger than that of the body of the screw, thus allowing for shrinkage and expansion without introducing force.

When fixing the central area of the panel, the diameter of the holes is the same as that of the body of the screw, fixing the panel rigidly. Your task is to ensure proper positioning.

The panel is fixed from the fixed points in order to position the panel. The expansion points are only made later, in order to avoid introducing stresses as the panels sag.

Note:

The support structure for the Viroc panels that will clad the façade can be made from wooden profiles or galvanised steel. Due to the high expansion coefficient of aluminium profiles, this type of structure is not permitted in this application.

Because the Viroc panel is not varnished, it is possible that with the wetting and drying cycles resulting from rain, the salts that constitute the cement may migrate to the surface, forming efflorescence. These efflorescences can form oozes, streaks of salts on the panels as the water drips.

It is also possible for there to be greater deformation both in the direction of the panel and outwards from the plane of the panel.

No claims will be accepted due to the appearance of leaks or excessive deformations.

2.3.01 Wooden support structure

The wooden support structure consists of pine wood beams fixed to the load-bearing structure (wall) using galvanised steel or stainless steel supporting squares, with metal anchors or anchors made up of metal screws and plastic bushings.

The strength of the wood used to make up the uprights must be of at least class C18 according to EN 338 and durability of class 2, 3 or higher according to EN 335. Wood of durability of class 2 must be protected with a protective strip.

When assembled on site, wooden uprights must not have a moisture level of more than 18%, with a difference between consecutive elements of no more than 4%. The relative moisture of the wooden uprights is determined according to the method described in standard EN 13183-2, using a tip moisture metre.

The cross-section of the uprights is generally rectangular, with a minimum dimension of 40x50 mm (see figure 2.3.1).

These elements are dimensioned taking into account the deformations caused by climatic actions and other factors (temperature, humidity, wind, etc.), so that they do not jeopardise the normal functioning of the façade. The deformation resulting from wind loads (pressure or depression) must not exceed the $L/200$ limit of the span between support fixings.

The width of the uprights must be such that the fixings can be positioned correctly, with the capacity to absorb small positioning errors. The screws must not be less than 15 mm from the end of the upright.

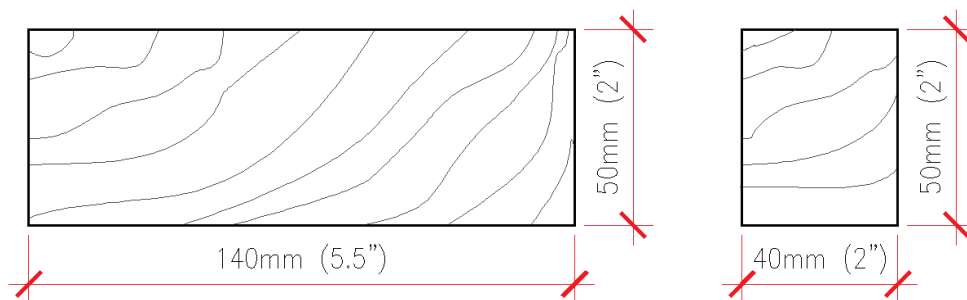

Figure 2.3.1 - Wooden structure

Minimum resistance of class C18 (EN 338) and durability of class 2 or 3 (EN335)

2.3.02 Galvanised steel support frame

The galvanised steel profiles are fixed to the load-bearing structure using galvanised or stainless steel supporting squares, with metal anchors or anchors made up of metal screws and plastic bushes.

The steel used in the upright profiles must be of minimum strength class S220GD+Z, in accordance with standard EN 10346.

The hot-dip zinc coating (Z) should be 275 g/m² in coastal areas and 140 g/m² in other areas.

The section of the profiles is generally Omega, U or L-shaped with a minimum thickness of 1.5 mm. Other profile shapes can be used, provided they have the same performance and durability (see figures 2.3.2 and 2.3.3).

The profiles used in plasterboard walls cannot be used as the steel thickness is less than 1.5 mm.

Omega profiles are used at the intersection of 2 panels. U and L sections are used as intermediate supports.

The sizing of these elements takes into account the deformations caused by climatic actions and other factors (temperature, humidity, wind, etc.), so that they do not jeopardise the normal functioning of the façade. The deformation resulting from wind loads (pressure or depression) must not exceed the $L/200$ limit of the span between support fixings.

The width of the profiles must be such that the fixings can be positioned correctly, with the capacity to absorb small positioning errors, and the screw must not be less than 10 mm from the end.

The distance between the profiles must respect the maximum distance between panel fixings. The alignment of the profiles between adjacent elements must be checked and must not differ by more than 2 mm.

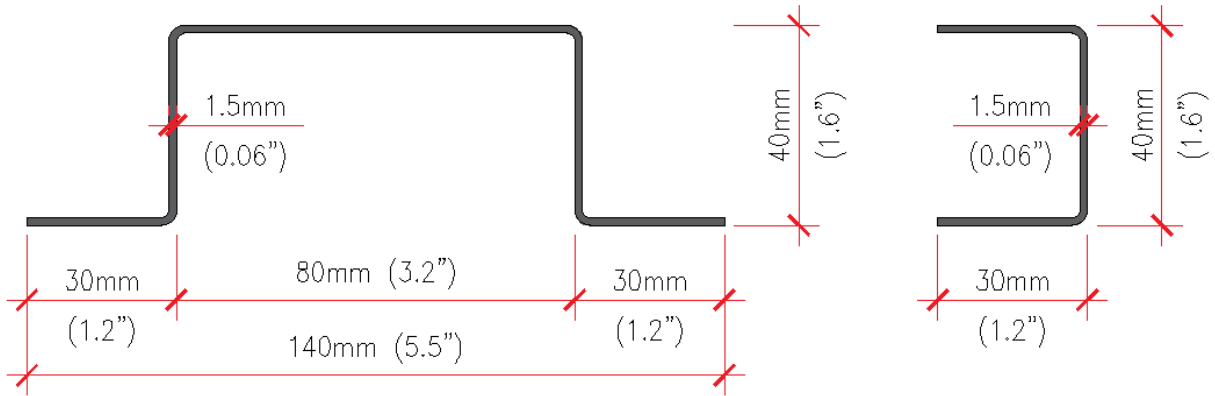

Figure 2.3.2 - Galvanised steel profiles
Minimum resistance of class S220GD (EN 10346)

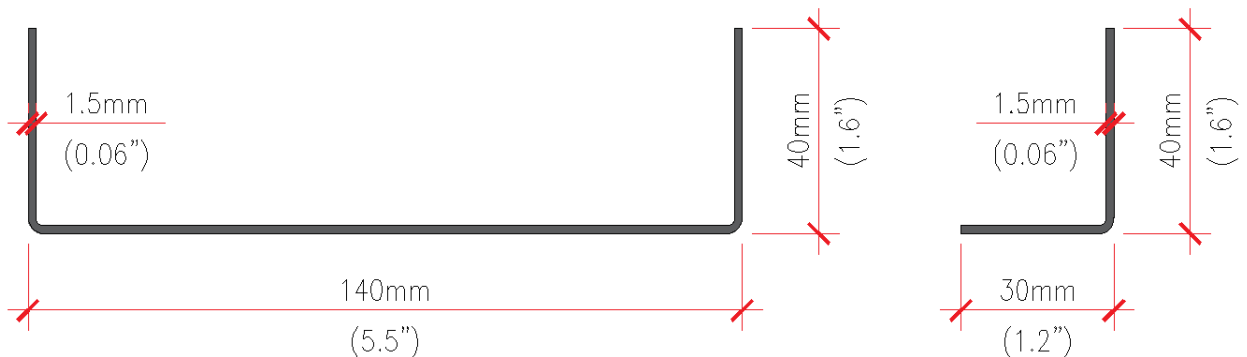

Figure 2.3.3 - Galvanised steel profiles (Alternative)
Minimum resistance of class S220GD (EN 10346)

2.3.03 Fixing supporting squares

The supporting squares for fixing the wooden or galvanised steel structure are made of a durable galvanised steel metal alloy of the minimum steel strength of class S220GD, according to EN 10147.

In coastal areas at a distance of 3 km from the sea, supporting squares must have special protection against corrosion, with a zinc weight of 275 g/m² or more, and can be made of stainless steel.

Squares are generally L-shaped, with several holes and a minimum thickness of 2.5 mm (see figure 2.3.4).

The supporting squares are dimensioned taking into account the façade own weight, based on a partial security coefficient of 1.5. The vertical deformation of the bracket must not exceed 3 mm for the maximum vertical load.

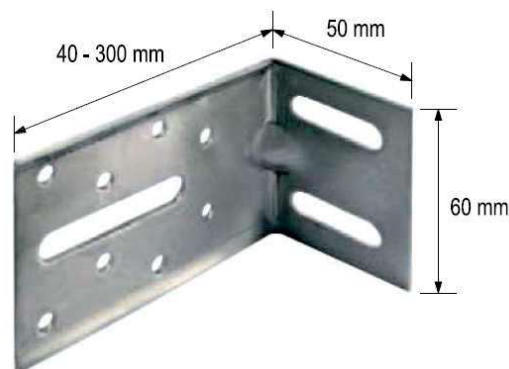

Figure 2.3.4 - Galvanised steel supporting squares
Minimum resistance of class S220GD. Minimum thickness: 2.5 mm

2.3.04 Anchors for fixing the supporting squares

The supporting squares are fixed to the support wall using anchors. The anchors can be metal bushes with a diameter of 8 mm or plastic bushes with a diameter of 10 mm and metal screws with a diameter of 7 mm (see figures 2.3.5 and 2.3.6).

With regard to the mechanical strength and stability of the anchors, they must be designed and built in such a way that the loads to which they will be subjected during their useful life do not involve one of the following consequences:

- Total or partial breakdown of the structure;
- Deformations that reach unacceptable proportions;
- Damage to other parts of structures, equipment or installations following excessive deformation of the supporting structure;
- Damage of great proportionality to the cause that originated it.

The anchorages must withstand shear loads, tensile loads and a combination of both during the expected life of the structure, ensuring:

- Adequate resistance to failure (Ultimate Strength Limits);
- Adequate resistance to displacement (Serviceability Limit States).

Anchorages must have an ETA (European Technical Assessment) certification with CE marking or, alternatively, a DH (Document of Homologation), containing the characteristic strength values and the respective security coefficients.

For anchorages without any type of ETA or DH certification, the resistance values must be proven through technical documents or load tests.

Metal bushings are generally suitable for concrete supports. Plastic bushings with metal screws are suitable for concrete supports and masonry with solid or hollow elements.



Figure 2.3.5 - Ø10 mm plastic anchor

Stainless steel or galvanised steel screw Ø7mm, minimum length 75 mm



Figure 2.3.6 - M8 metal anchor

Stainless or galvanised steel, minimum length 80 mm

2.3.05 Bushings for fixing thermal insulation

The thermal insulation is dimensioned in accordance with the thermal conditioning rules of the RCCTE - Regulation on the Thermal Behaviour Characteristics of Buildings (*RCCTE-Regulamento das Características do Comportamento Térmico dos Edifícios*).

It is fixed to the support using plastic bushings or similar material, normally with a wide head and the appropriate length for the thickness of the insulation (see figure 2.3.7).



Figure 2.3.7 - Bushings for fixing thermal insulation to the support structure

2.3.06 Wooden upright protection strips

When the structure consists of wooden uprights that are durability of class 2 according to EN 335, they must be protected from rainwater with a protective band across their entire height.

This strip must be waterproof and 10 mm wider than the uprights on each side.

The strips can be made of flexible PVC or EPDM (see figure 2.3.8).

Protection strips can also be used on metal profiles, as an option.



Figure 2.3.8 - Flexible PVC or EPDM protection strip

Mandatory installation in wooden uprights with durability of class 2

2.3.07 Screws for fixing the panels to a wooden frame

The screws must be at least class A2 stainless steel, with a body diameter of 4.8 mm and a head diameter of 16 mm. A neoprene washer can be fitted to control the clamping force (see figure 2.3.9).

Screws with a smaller head diameter can be used, as long as they are applied with a 16 mm diameter metal washer with neoprene. The screw pulling force (P_K) must be greater than 2.0 kN (± 200 Kgf) for a penetration depth of 22 mm into the wood.

SFS Intec, ETANCO and EJOT manufacture specific screws for façade and can supply them lacquered in the desired colour.

Screws from other manufacturers can be used as long as they have the same performance.

TW-S-D16-4.8x38 W16 (SFS Intec)
Torx Panel Bois TB-16 TX20-4.8x38 A16 (ETANCO)

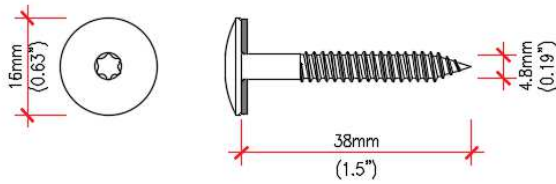

TW-S-D12-S16-4.8x44 (SFS Intec)

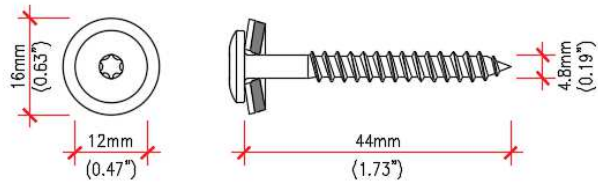

TW-S-D12-S16-4.8x38 (SFS Intec)
Torx Panel Bois TB-12 TX20-4.8x38 A16 (ETANCO)

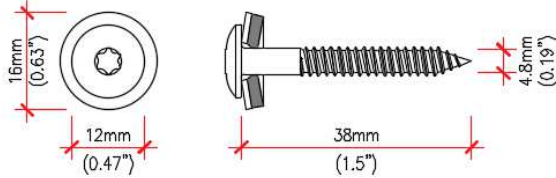

TW-S-D12-S16-4.8x60 (SFS Intec)
Torx Panel Bois TB-12 TX20-4.8x60 A16 (ETANCO)

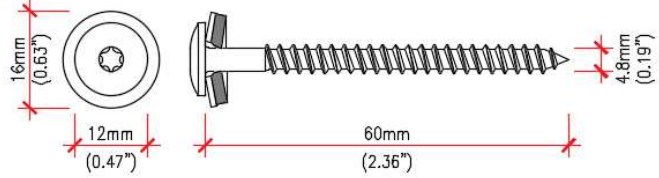

JT4-LT-2/6-6.0x50 KD16 (EJOT)

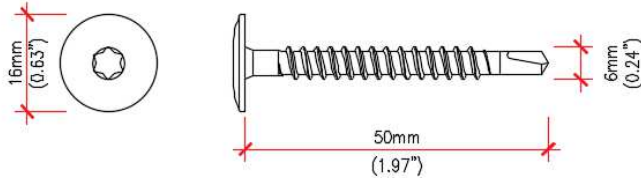

Figure 2.3.9 - Screws for wooden structures

2.3.08 Screws for fixing the panels supported on a galvanised steel frame

The screws for fixing the Viroc panels to the galvanised steel structure must be bimetallic, with a stainless steel body and a carbon steel drilling tip. The diameter of the head will be 16 mm and the body at least 5.5 mm. Screws with a smaller head diameter can be used as long as they are applied with a neoprene metal washer with a diameter of 16 mm. The length of the screw must be suitable for the connection between the thickness of the panel and that of the metal profile (see figure 2.3.10).

The pull-out force of the bolt (P_k) must be greater than 2.0 kN for any type of structure.

SFS Intec, ETANCO and EJOT manufacture specific rivets for façade and can supply them lacquered in the desired colour.

Screws from other manufacturers can be used as long as they have the same performance.

SX3/15-L12-S16-5.5x32 (SFS Intec)

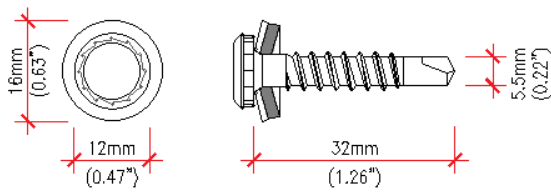

SX5-L12-S16-5.5x41 (SFS Intec)

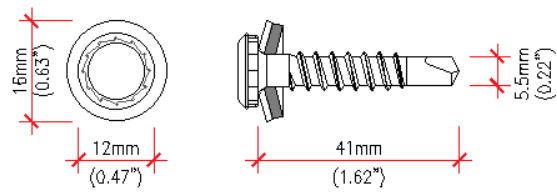

SX3/15-D16-5.5x30

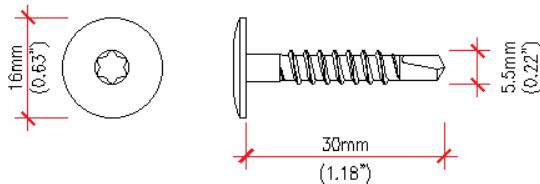

STARZAC/2C 5.5x38 W16 (ETANCO)

STARZAC/2C 6.3x50 W16 (ETANCO)

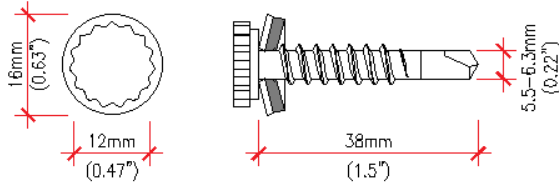

DRILLNOX STAR 5.5x50 A16 (ETANCO)

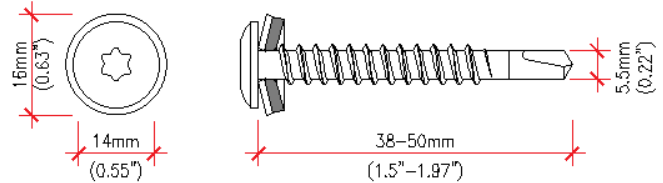

JT3-LT-3-5.5x30 KD16 (EJOT)

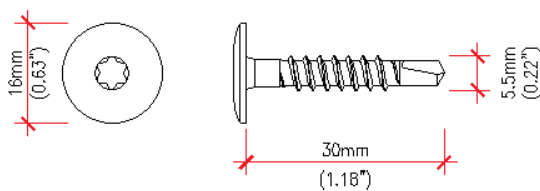

JT3-FR-3-5.5x50 E16 (EJOT)

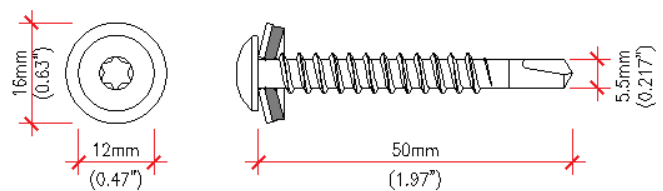

Figure 2.3.10 - Screws for metal structures

2.3.09 Rivets for fixing the panels supported on a frame made of galvanised steel

When the support structure is made of galvanised steel, rivets can be used to attach the Viroc panels. The rivets to be used consist of an aluminium body and a stainless steel pulling mandrel. The diameter of the rivet body must be at least 4.8 mm and the length must be suitable for attaching the panel to the structure (see figure 2.3.11).

The rivet pull-out force (PK) must be greater than 2.0 kN for any type of structure.

When panels are fixed with rivets, a tightening stop must be placed on the tip of the riveting tool, so as not to over-tighten and allow for normal shrinkage and expansion of the panel (see figure 2.3.12).

SFS Intec, ETANCO and EJOT manufacture specific rivets for façade and can supply them lacquered in the desired colour.

Rivets from other manufacturers can be used as long as they have the same performance.

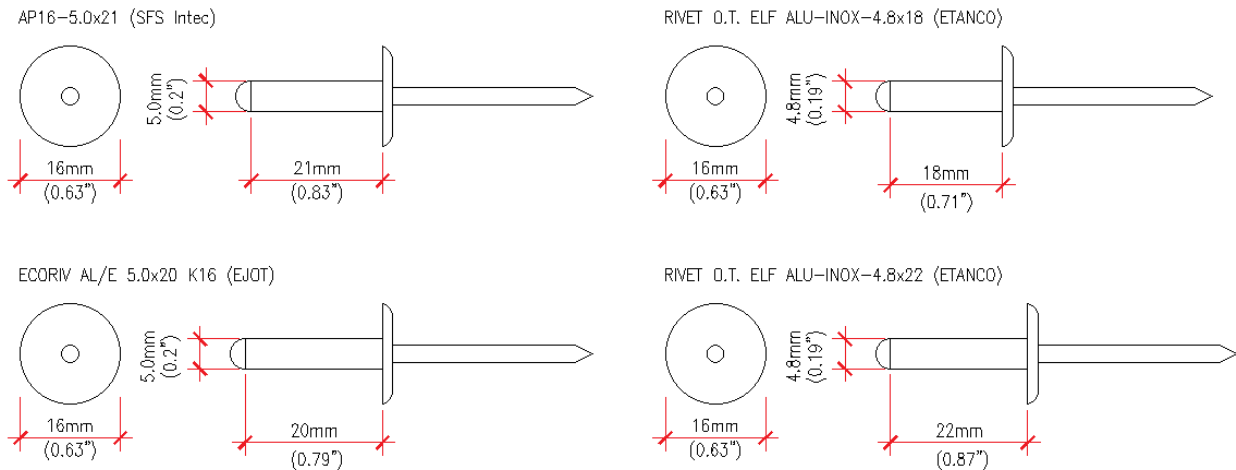

Figure 2.3.11 - Rivets for fixing Viroc panels to a metal structure

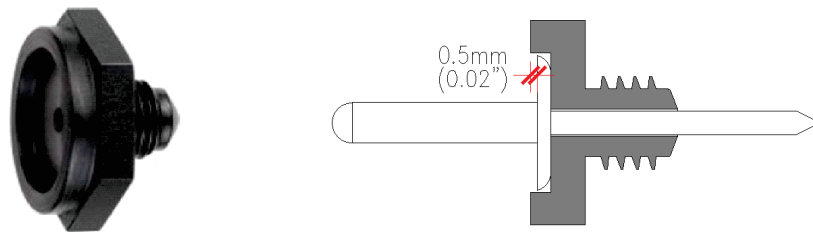

Figure 2.3.12 - Clamping nozzle, screwed into the riveting tool mouth

Mandatory use

2.3.10 Recommended thicknesses of Viroc façade panels and their tolerance

Thickness: 12 mm \pm 1.0 mm; 16 mm \pm 1.2 mm

See the Viroc panel technical data sheet for the range of thicknesses and colours available.

2.3.11 Panel weight

12 mm: 16.2 \pm 1.2 kg/m²;

16 mm: 21.6 \pm 1.6 kg/m².

2.3.12 Viroc panel manufacturing dimensions and cutting tolerances

Dimensions: 2600x1250 mm and 3000x1250 mm

Tolerances: Length and width: \pm 3 mm

Squaring: \leq 2 mm/m

Edge straightness: \leq 1.5 mm/m

Consult the Viroc panel's technical data sheet to see the range of sizes and colours available.

Any intermediate dimensions obtained by cutting the panels are possible.

2.3.13 Maximum format of panels applied to unvarnished façade

The largest dimension of the panel to be applied to a ventilated façade without varnish is 1500x625 mm.

2.3.14 Minimum format for façade panels

The smallest panel size to be applied to a ventilated façade is 300 mm.

Viroc Portugal does not recommend that the ratio between the length and width of the panel exceeds 3 ($L/B \leq 3$).

A panel that is too long and narrow tends to break easily.

2.3.15 Façade assembly operations

A façade is installed as follows:

- a. Marking and identification of façade elements;
- b. Mounting the supporting squares;
- c. Installation of thermal insulation;
- d. Assembly of the support profiles/mounts;
- e. Fixing the panels;
- f. Treatment of singular points.

2.3.16 Marking and identification of façade elements

There is no preferred assembly orientation. The system allows the assembly of all sizes and formats of intermediate dimensions. Viroc panels can be placed horizontally or vertically.

The aim is to follow the stereotomy defined by the architectural project.

2.3.17 Mounting the supporting squares

The location of these elements determines the final position of the support profiles, so they must be positioned precisely.

2.3.18 Fixing supporting squares to the supporting wall

The supporting squares are fixed to the support wall using anchors. The anchors can be metal bushes with a diameter of 8 mm or plastic bushes with a diameter of 10 mm and a metal screw with a diameter of 7 mm.

2.3.19 Angle plates

There are angle plates that make it easier to make corner angles. Its use is optional (see figure 2.3.13).

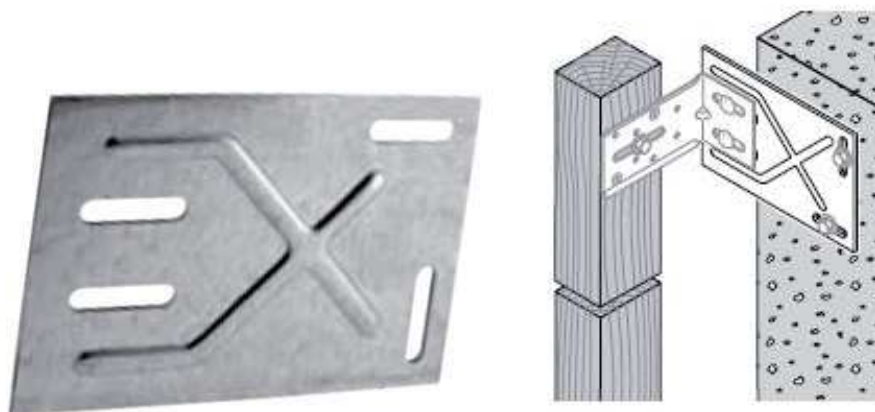

Figure 2.3.13 - Auxiliary angle plate, galvanised steel Z350. Thickness: 2.5 mm

2.3.20 Fitting the thermal insulation

The thermal insulation is dimensioned in accordance with the thermal conditioning rules of the RCCTE - Regulation on the Thermal Behaviour Characteristics of Buildings (RCCTE-Regulamento das Características do Comportamento Térmico dos

Edificios). It is fixed to the support using plastic bushes or similar material, normally with a wide head and the appropriate length for the thickness of the insulation.

2.3.21 Mounting the support profiles

The support profiles are arranged vertically in accordance with the specifications and technical drawings presented in this document, duly adapted to the stereotomy of the architectural project.

The profiles can be laid horizontally as long as there is room for air ventilation and the profiles do not accumulate water, which can degrade them.

The distance between profiles/mounts must respect the maximum distance between the panel fixings, the alignment of the uprights between adjacent elements must be checked and must not differ by more than 2 mm.

2.3.22 Fixing the profiles to the supporting squares

Fixing the wooden uprights to the supporting squares

The wooden uprights are connected to the supporting squares using a $\varnothing \geq 6.0$ mm screw placed in the oval hole and a second $\varnothing \geq 3.5$ mm screw placed in one of the circular bolt holes to block movement (see figure 2.3.14).

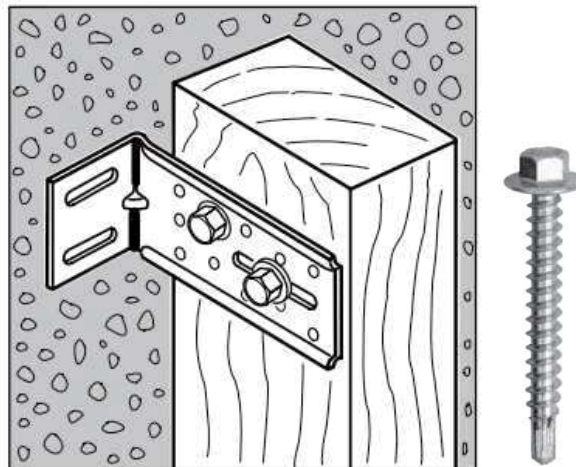

Figure 2.3.14 - Fixing the wooden uprights to the supporting squares (2 $\varnothing \geq 6$ screws)

Fixing the galvanised steel profiles to the supporting squares

The galvanised steel profiles are connected to the supporting squares using self-drilling screws or rivets placed in the oval bolt hole and another screw placed in one of the circular bolt holes to block movement. The connection can be made with self-drilling screws $\varnothing \geq 5.5$ mm or rivets $\varnothing \geq 4.8$ mm (see figure 2.3.15).

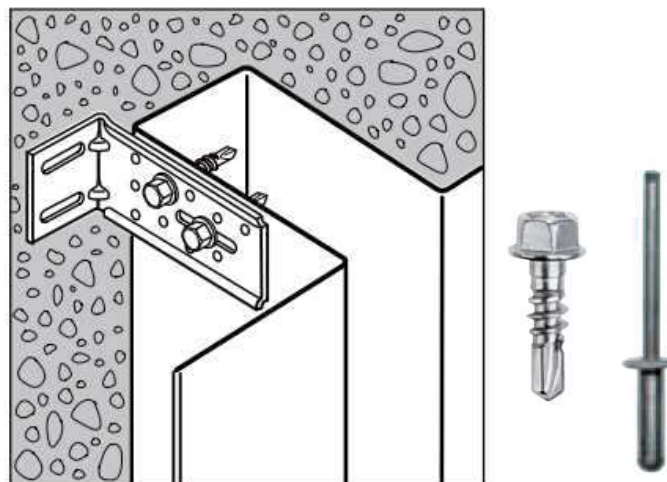

Figure 2.3.15 - Fixing the galvanised steel profiles to the supporting squares ($\varnothing \geq 5.5$ screws or $\varnothing \geq 4.8$ rivets)

2.3.23 Wooden upright protection strips

Whenever the structure is made of durability of class 2 wood (EN 335), it must be protected against rainwater with a flexible PVC or EPDM band over its entire height.

Protective strips can also be used on metal profiles, as an option.

2.3.24 Cutting Viroc panels

Cuts to be made in Viroc panels should be made using a portable circular saw with suitable cutting blades. The cutting edges of the disk must be made of hard metal, usually tungsten carbide inserts (see figure 2.3.16).

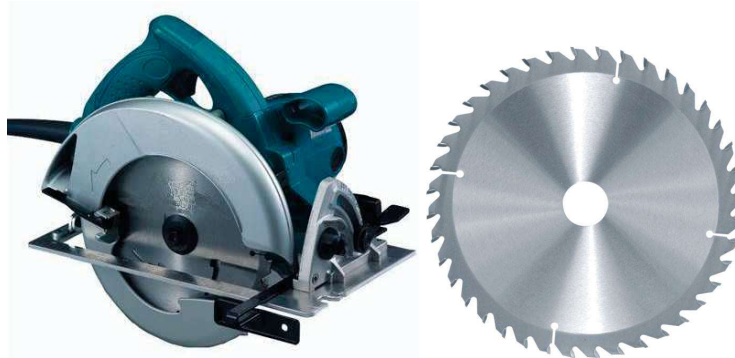

Figure 2.3.16 - Circular saw with tungsten cutting disc

2.3.25 Drilling Viroc panels

If holes need to be drilled in the Viroc panels, they must be drilled with HSS metal drills and the drill must be in drilling mode, without impact (see figure 2.3.17).



Figure 2.3.17 - HSS drill and bits (for drilling metal)

2.3.26 Preparing the surface of the Viroc panels

Viroc panels are supplied raw and unfinished. The surfaces show some irregularities and imperfections, such as small incrustations, stains, scratches, small wood chips and salts from chemical reactions.

Before a finishing varnish is applied, the surfaces must be completely clean and dry, with no grease, dust or surface salts. The surfaces that will be visible should be cleaned/polished with a cleaning disk or alternatively the surface can be sanded with fine 120 grit sandpaper or higher.

Cleaning/polishing does not alter the natural appearance of the panel; it maintains the stains and heterogeneities that characterise it, as well as some salts and incrustations that are embedded in the surface.

Video showing how Viroc panels are polished.

<https://www.youtube.com/watch?v=HeQZNVNOZYI>

2.3.27 Varnishing or painting Viroc panels

This chapter refers to the application of the Viroc panel on unvarnished façade.

2.3.28 Fixing Viroc panels

The Viroc panels that constitute the façade are fixed to a structure using screws.

The panels, when placed outdoors, are subject to dimensional variations of +1.5 mm to -5.0 mm per linear metre when the panel is not sealed.

In order to allow for dimensional variations in the panels, without introducing force that could damage the panels, the fixing system must allow for dimensional variation.

The diameter of the bolt holes to be drilled in the panels for fixing the screws located near the periphery is 10 mm larger than the body of the screw, thus allowing for shrinkage and expansion without introducing force.

When fixing the central area of the panel, the diameter of the bolt holes is the same as that of the body of the screw, fixing the panel rigidly. Its function is to ensure the proper positioning of the panel.

Fixing starts from the fixed points in order to position the panel. The expansion points will only be made later, in order to avoid introducing stresses as the panels sag.

The screws are positioned at a distance of 50 to 75 mm from the edges of the panels. The maximum distance between screws is 700 mm both horizontally and vertically, as shown in figure 2.3.18.

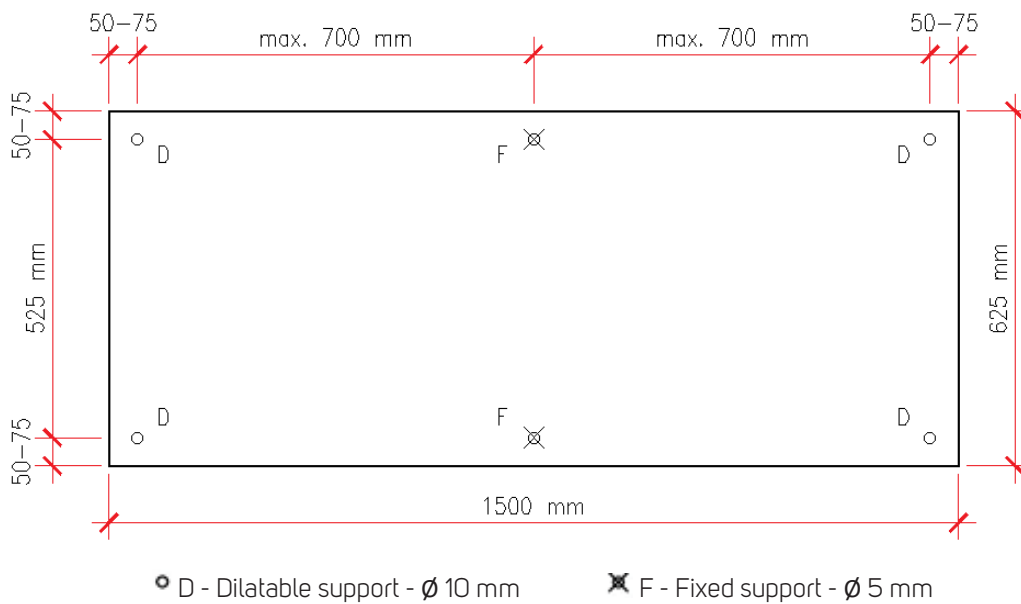

Figure 2.3.18 - Location of fixings and hole diameter

The positioning of the screws for fixing the façade panels must be perpendicular to the plane, with a maximum error of 2.5° and correctly tightened without crushing the neoprene washer (see figures 2.3.19 and 2.3.20).

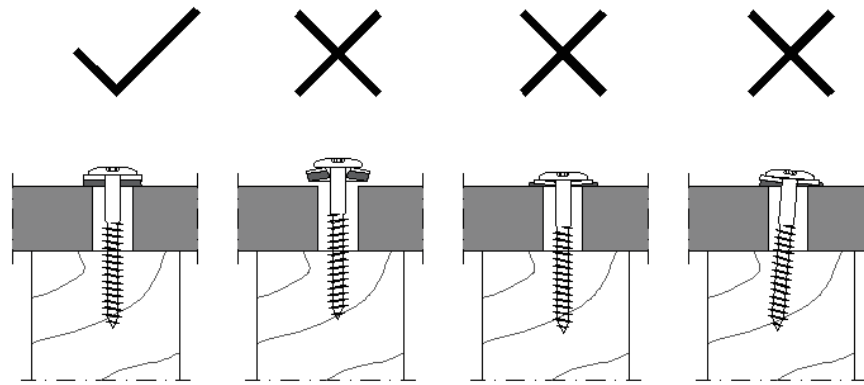

Figure 2.3.19 - Correct tightening and positioning of the screws

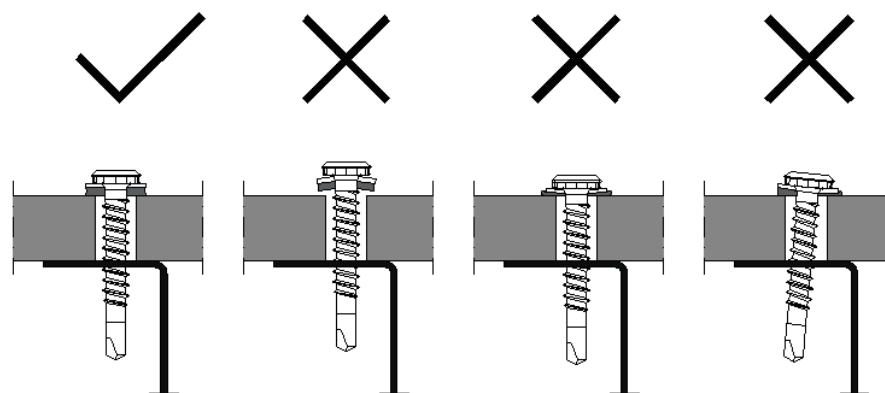

Figure 2.3.20 - Correct tightening and positioning of the screws

The location of the screws when fixed to a wooden structure must not be less than 15 mm from the edge of the wooden beam (see figure 2.3.21).

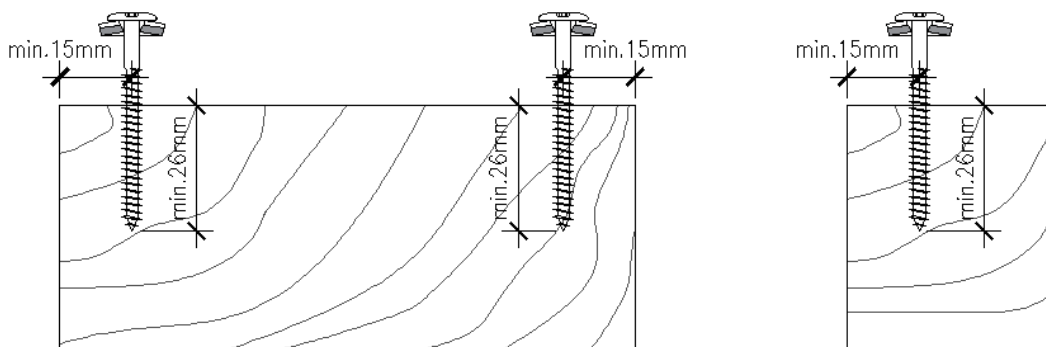

Figure 2.3.21 - Minimum distance from the screws to the edges of the beams

If the structure is made of galvanised steel, the distance to the edge must not be less than 10 mm (see figure 2.3.22)

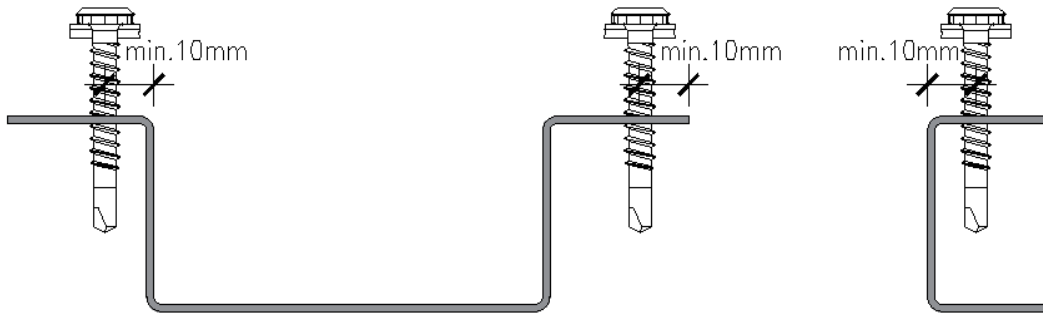

Figure 2.3.22 - Correct positioning of screws or rivets

2.3.29 Auxiliary assembly tools

There are various auxiliary tools that can be used to facilitate assembly work, such as spanners for centering bolt holes and screws (see figures 2.3.23, 2.3.24 and 2.3.25).



Figure 2.3.23 - Spanner for centering screws



Figure 2.3.24 - spanner for bolt hole-centering



Figure 2.3.25 – Bolt hole-centering tool

2.3.30 Treatment of the joints

Viroc panels are installed so that the joints between the panels, both vertical and horizontal, have a gap of between 5 and 8 mm. The joints can remain open or closed with a profile for aesthetic reasons.

2.3.31 Air foil ventilation

The ventilated façade, as recommended in this Technical File, forms a continuous sheet of air between the back of the panel and the thermal insulation.

The minimum opening for ventilation of the air foil is 20 mm thick. This distance must be respected even in areas where there may be obstructions.

At the base of the façade, the opening must be protected by a grille or perforated plate to prevent birds or rodents from entering (see figure 2.3.26).



Figure 2.3.26 - Perforated anti-rodent profile

The opening at the top of the façade is protected by a ruffle to prevent water from entering directly into the air gap.

The air gap must be compartmentalised, both vertically and horizontally, without impeding the free circulation of air.

The purpose of this compartmentalisation is to prevent the spread of fire between different floors or elevations in the event of a fire.

The air gap can be compartmentalised using galvanised steel sheet or aluminium. See general details.

2.3.32 Angle profiles

Some manufacturers of accessory elements for façade have auxiliary profiles for finishing the corners of the façade. The use of these profiles is optional (see figures 2.3.27 and 2.3.28).



Figure 2.3.27 - Corner angle profiles



Figure 2.3.28 - Corner angle profiles

2.3.33 Cleaning the panels after application

Panels can be cleaned during the life of the project by spraying them with water and a neutral detergent.

2.3.34 Replacing a panel

To replace a façade panel, the existing panel must first be removed.

Before starting to install a new panel, it is necessary to check that the supporting structure is in a position to receive and support the new façade panel.

It is necessary to check that the structure is aligned and level with the rest of the façade and that the area where the new screws are to be placed is intact; otherwise it needs to be repaired.

2.3.35 Impact resistance

Hard Body Impact Energy EN 1128

12 mm, E = 12.9 Joules, Burst Energy

16 mm, E = 12.8 Joules, Burst Energy

Impact test according to ETAG 034

12mm thick panel

Type of Impact	Energy	Results
Hard Body	1 J	No damage (Pass)
	3 J	No damage (Pass)
Soft Body	20 J	No damage (Pass)
	60 J	No damage (Pass)
	100 J	No damage (Pass)
	130 J	No damage (Pass)
	300 J	Fail

2.3.36 Wind action

Exposure to wind action perpendicular to the plane of the panel corresponds to a pressure or depression (in kN/m²) whose design resistance value is given in Tables 1, 2 and 3.

2.3.37 Wind safety check

Wind loads are quantified in accordance with the National Annex of Eurocode 1 (RSA).

The wind resistance load tables were drawn up on the basis of experimental tests for the situation that most affects a panel resistance to wind loads: suction.

2.3.38 Example of Safety check of a Viroc panel to wind loads

For a 12 mm thick Viroc panel with the configuration shown below, what is the maximum wind load the panel can withstand?

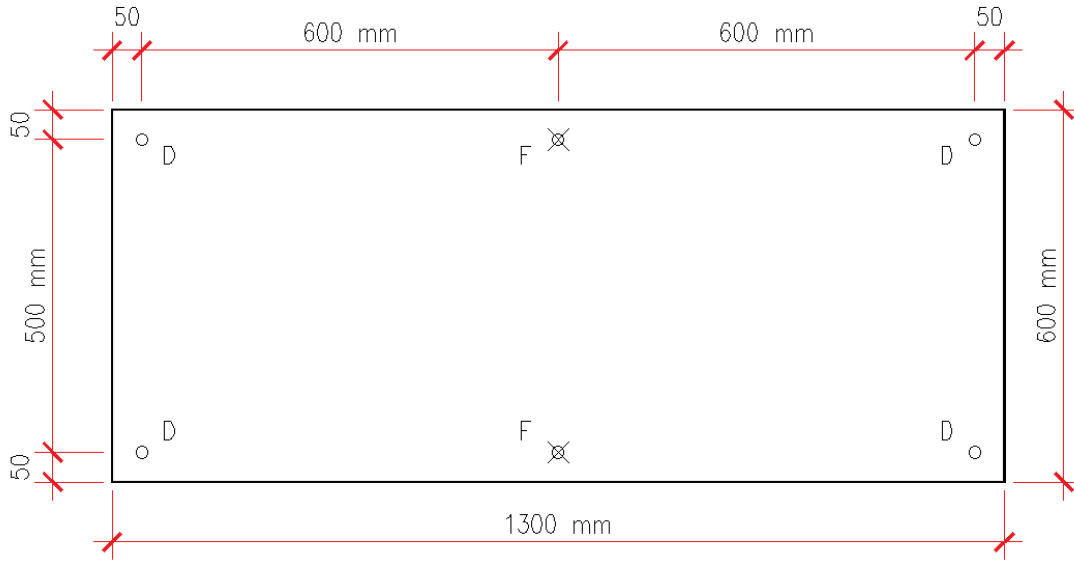

Number of screws horizontally: 3

Number of vertical screws: 2

Configuration: 3x2, we use the 3x2 table

Distance between screws horizontally: 600 mm => See Table 4

Distance between screws vertically: 500 mm

Horizontal distance between screws 600 mm (24")											
Thickness of panel	(H x V)	Vertical distance between screws									
		300 mm kN/m ²	12" psf	400 mm kN/m ²	16" psf	500 mm kN/m ²	20" psf	600 mm kN/m ²	24" psf	700 mm kN/m ²	28" psf
12 mm 1/2"	2 x 2	1,4	29	1,4	29	1,4	29	1,2	25	1,0	21
	2 x 3	1,4	29	1,4	29	1,2	24	1,0	20	0,8	17
	2 x N	1,4	29	1,4	29	1,2	24	1,0	20	0,8	17
	3 x 2	1,7	36	1,4	28	1,1	24	1,0	20	0,9	18
	N x 2	1,7	36	1,4	28	1,1	24	1,0	20	0,9	18
	3 x 3	1,5	32	1,2	24	0,9	19	0,8	16	0,7	14
	3 x N	1,5	32	1,2	24	0,9	19	0,8	16	0,7	14
	N x 3	1,5	32	1,2	24	0,9	19	0,8	16	0,7	14
16 mm 5/8"	2 x 2	3,3	69	3,3	69	3,0	62	2,5	53	2,2	46
	2 x 3	3,3	69	3,1	64	2,5	52	2,1	43	1,8	37
	2 x N	3,3	69	3,1	64	2,5	52	2,1	43	1,8	37
	3 x 2	3,6	75	2,9	60	2,4	50	2,1	43	1,8	38
	N x 2	3,6	75	2,9	60	2,4	50	2,1	43	1,8	38
	3 x 3	1,7	35	1,3	27	1,0	21	0,8	18	0,7	15
	3 x N	1,7	35	1,3	27	1,0	21	0,8	18	0,7	15
	N x 3	1,7	35	1,3	27	1,0	21	0,8	18	0,7	15

Table 4 - Allowable pressure, 600 mm spacing between screws horizontally

The design resistance value of the Viroc panel to wind pressure (w_{Rd}) is 1.1 kN/m² (24 psf)

Note: The action of the wind exerts a pressure or depression on the panel. This is a constraint when it acts as a depression, since the panel is fixed only by the head of the screws and breakage occurs by cutting/punching the panel in these areas.

2.3.39 Run-off

With the wetting and drying cycles of the panels, due to the action of rain, there is the possibility that the salts that constitute the cement migrate to the surface, forming efflorescence. These efflorescences can form oozes, streaks of salts on the panels as the water drips. This salt run-off on the surface of the panels can be minimised if the panels are polished when they are applied.

2.3.40 Surface warping

As the panel is not sealed, it may suffer greater dimensional variation, which will occur both in the plane of the façade and outside the plane of the façade.

2.3.41 Details, wooden structure

Figures 2.3.29 to 2.3.43 show examples of various details and unique areas of the façade.

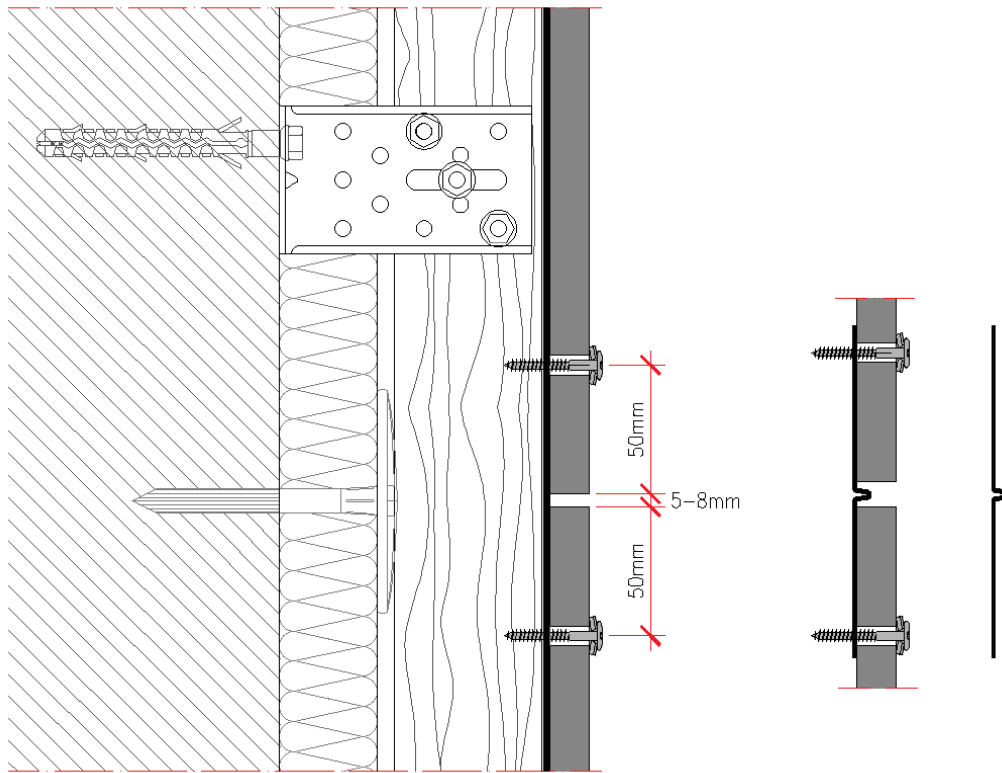

Figure 2.3.29 - Vertical section, joint between panels

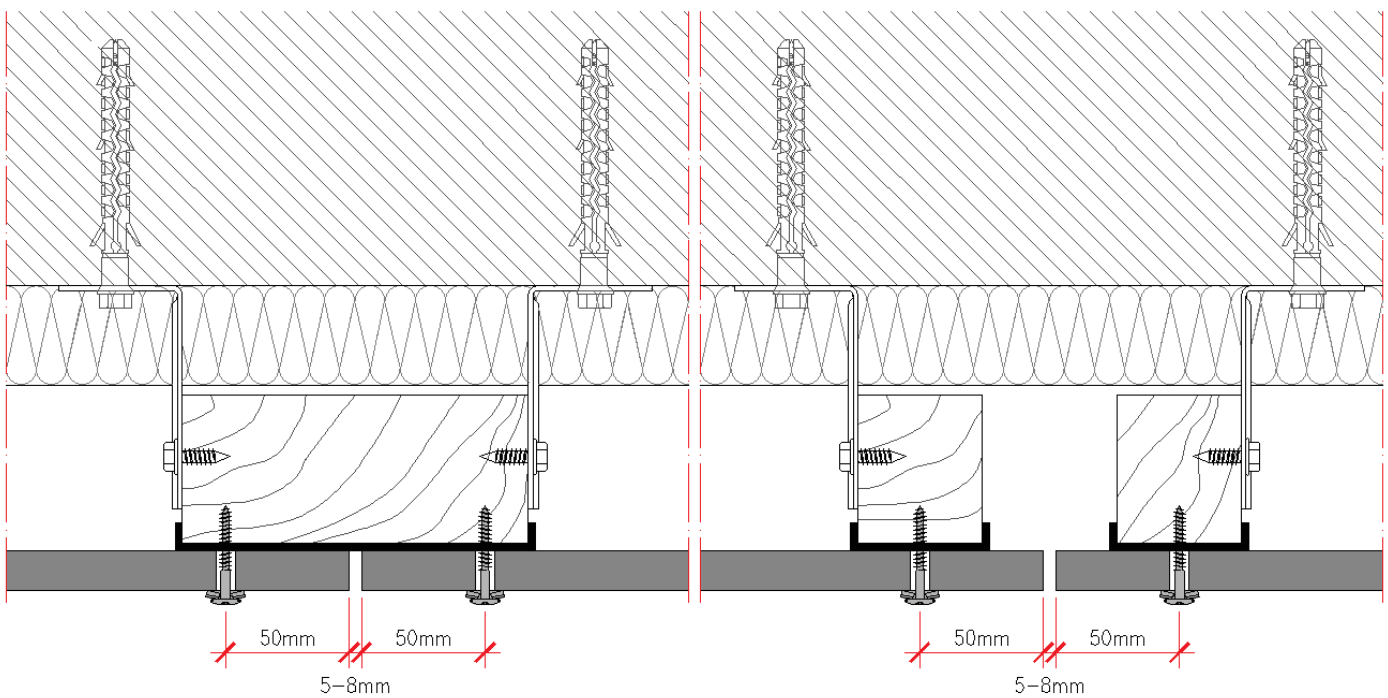

Figure 2.3.30 - Horizontal section, joint between panels

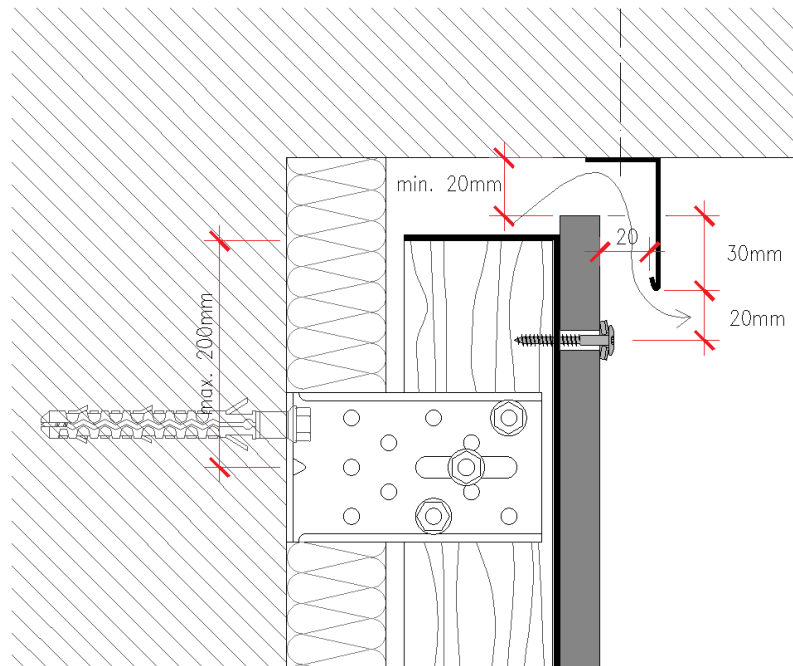

Figure 2.3.31 - Balcony finish

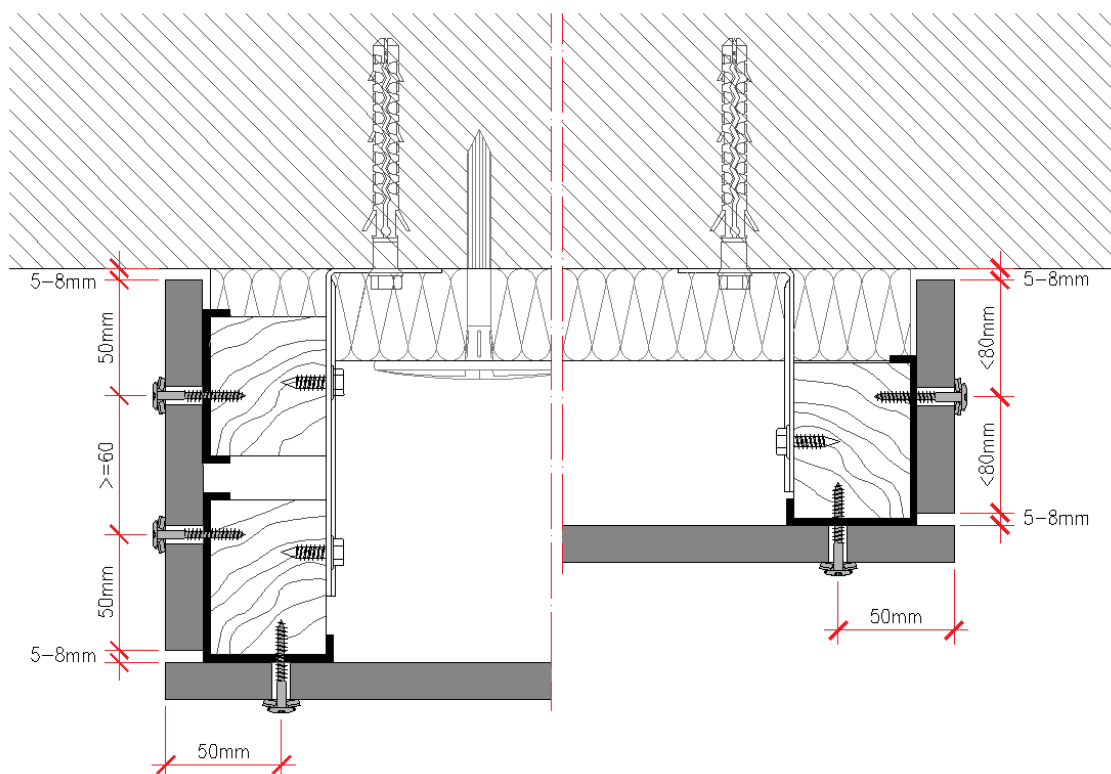

Figure 2.3.32 - Side finish

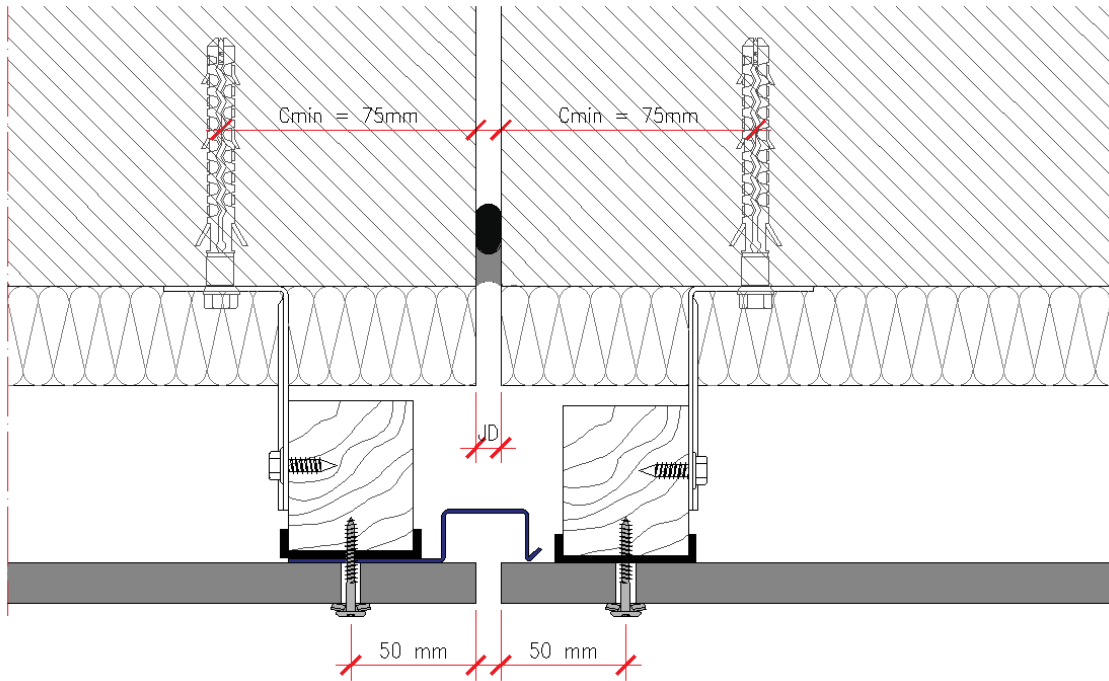

Figure 2.3.33 - JD-Expansion joint

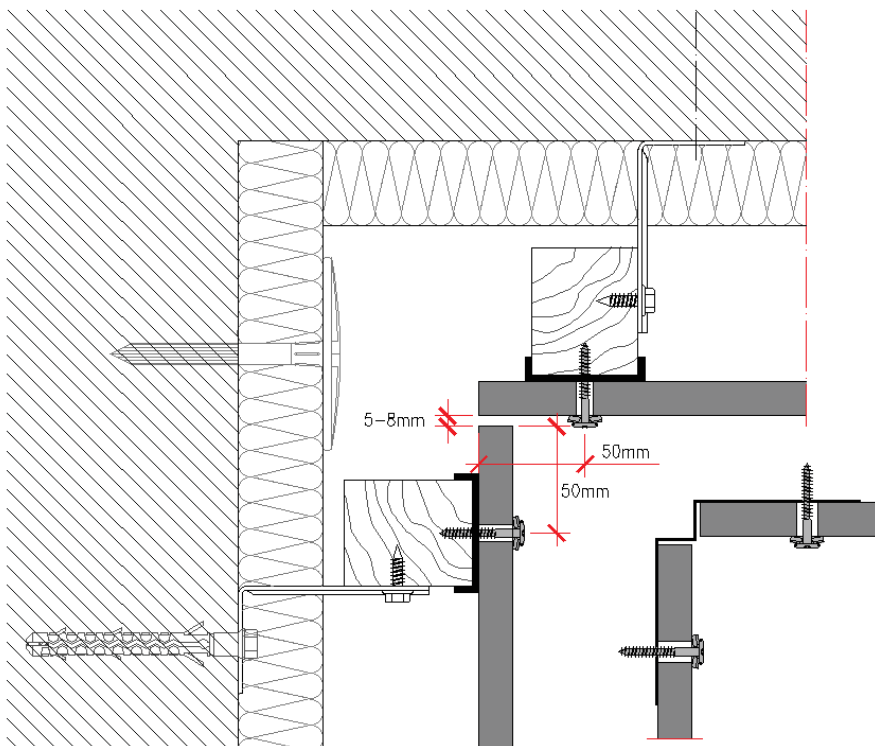
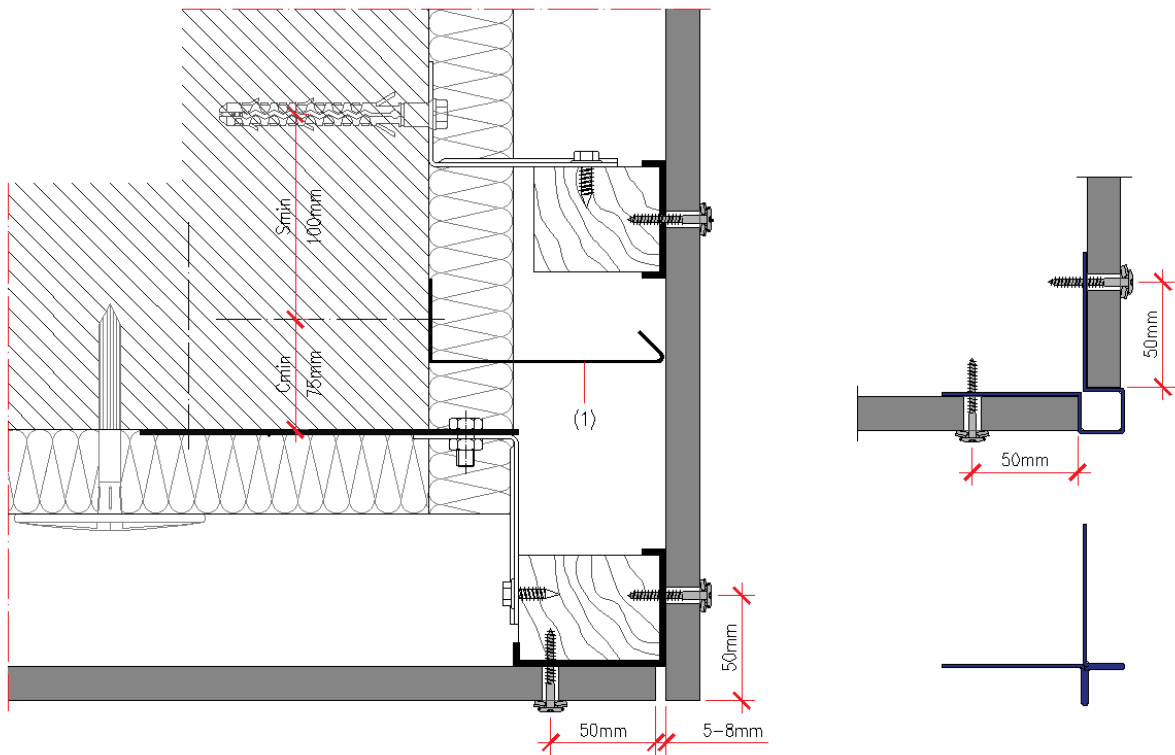

Figure 2.3.34 - Corner angle



(1) Compartmentalisation of the air foil

Figure 2.3.35 - Corner angle

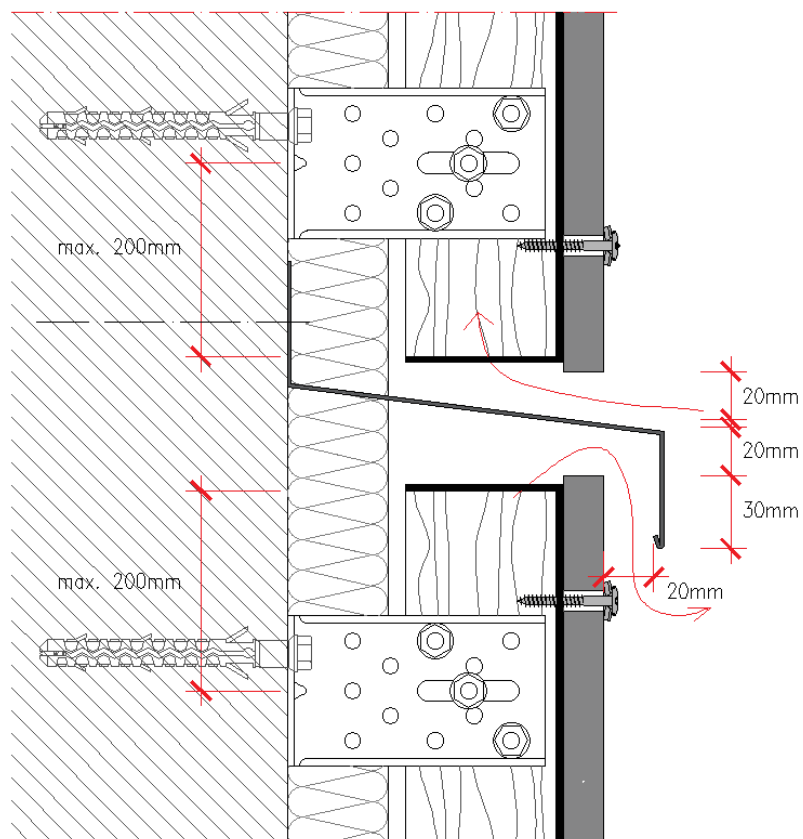

Figure 2.3.36 - Horizontal compartmentalisation of the air gap

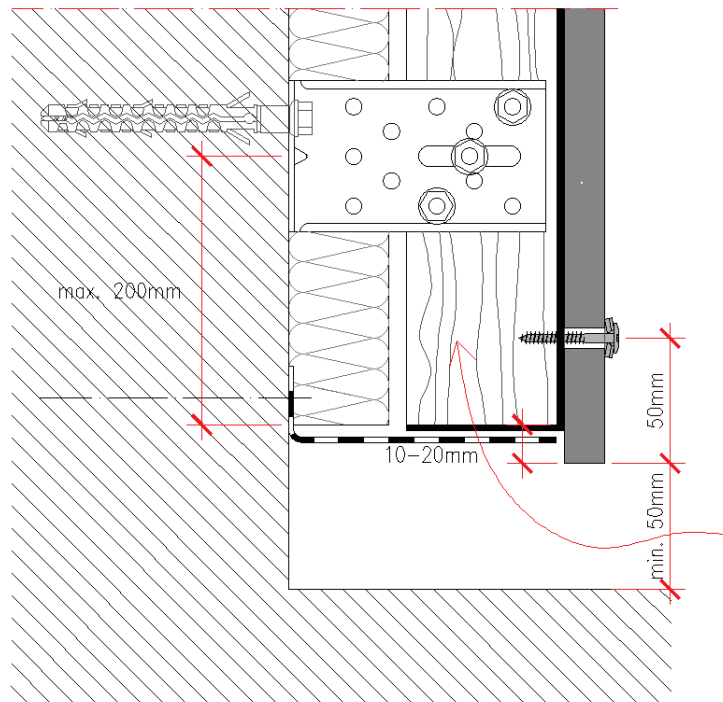

Figure 2.3.37 - Detail of the base, anti-rodent grid

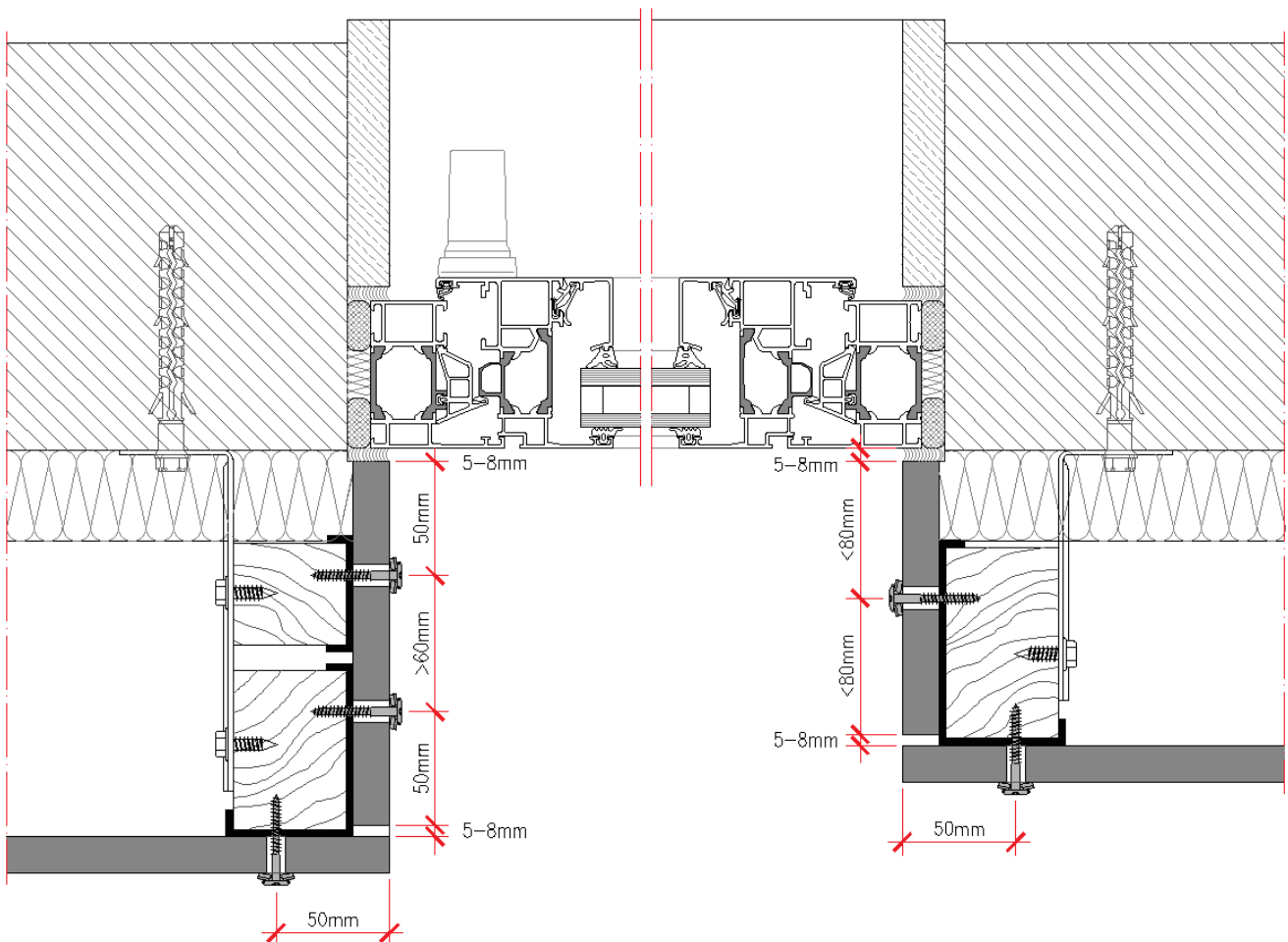

Figure 2.3.38 - Horizontal section, window opening

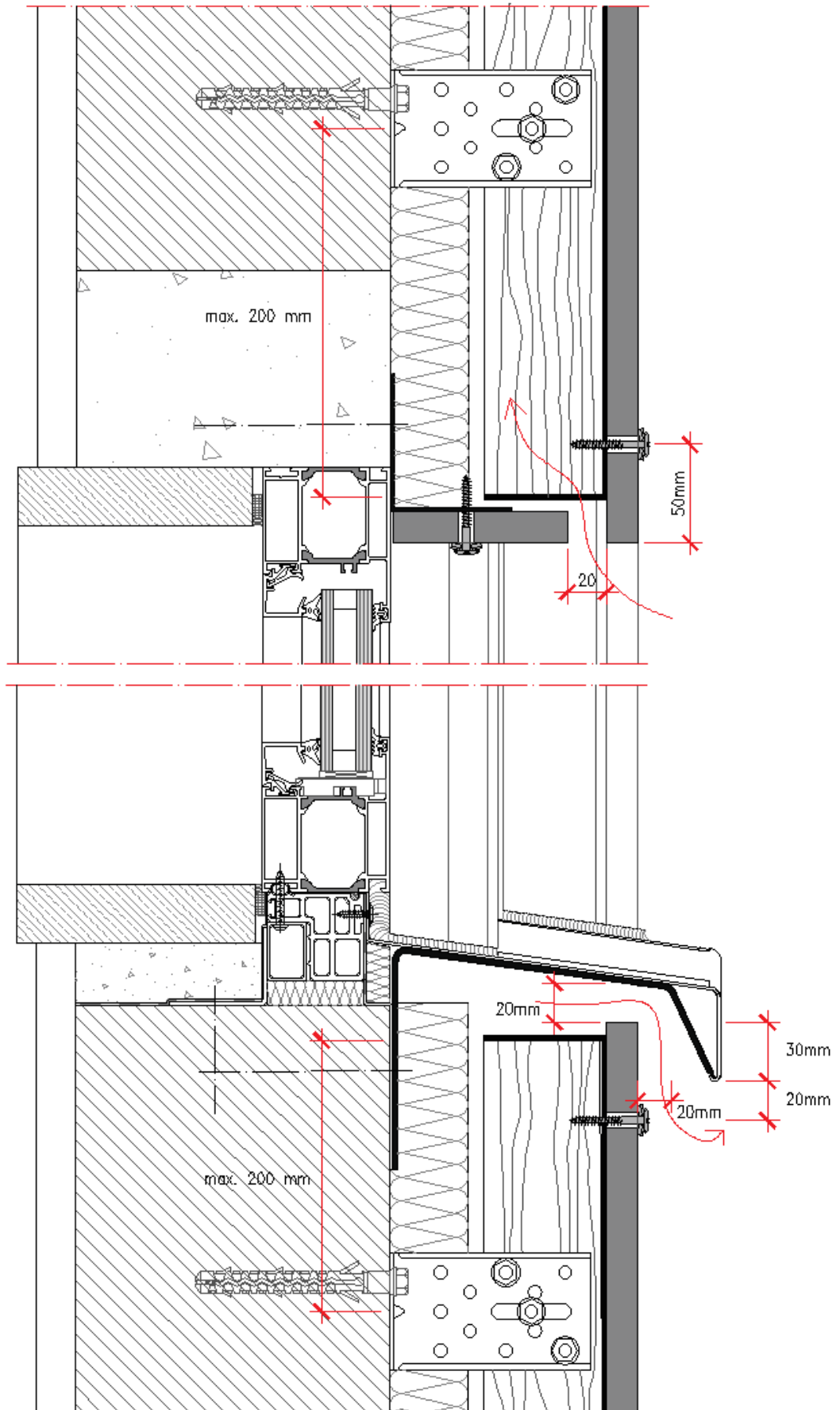

Figure 2.3.39 - Vertical section, window opening

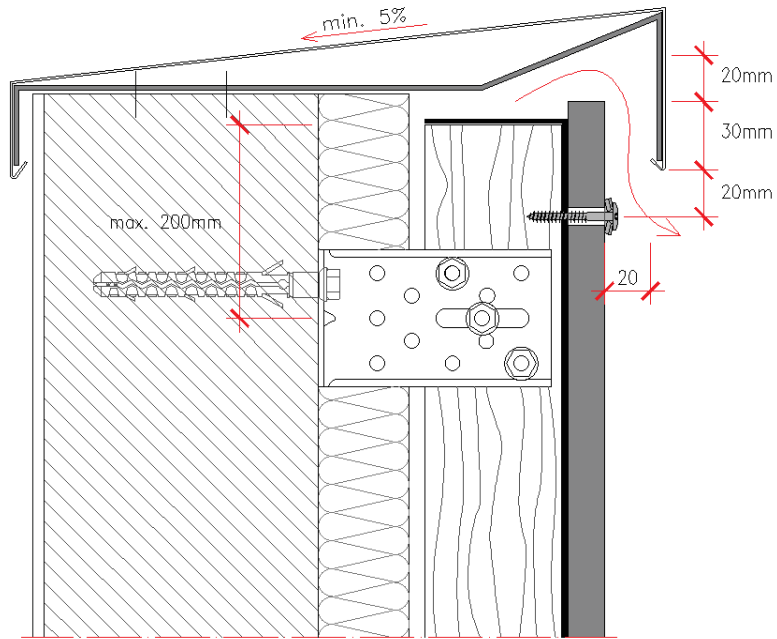

Figure 2.3.40 - Detail of the top

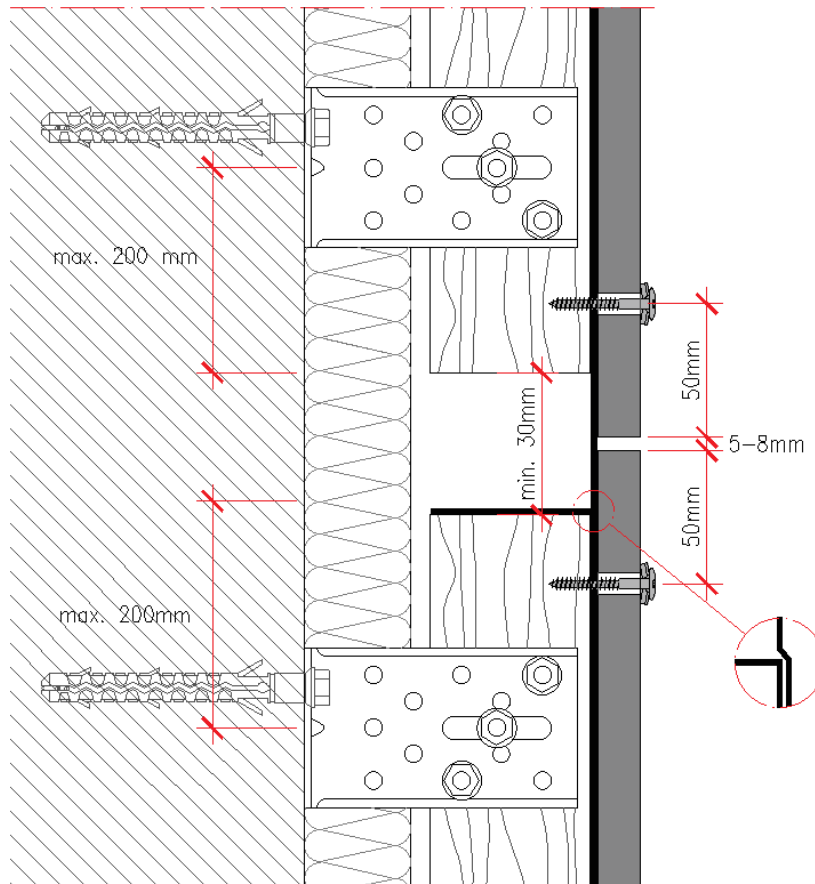

Figure 2.3.41 - Fractionation of the structure: Profiles with length ≤ 6 m

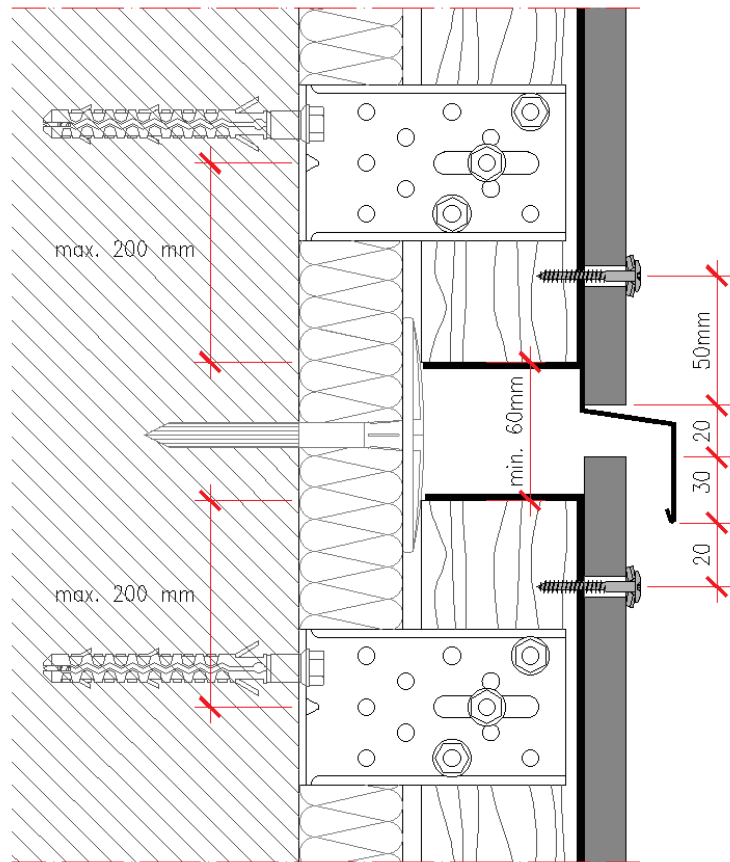

Figure 2.3.42 - Fractionation of the structure: Profiles with length > 6 m

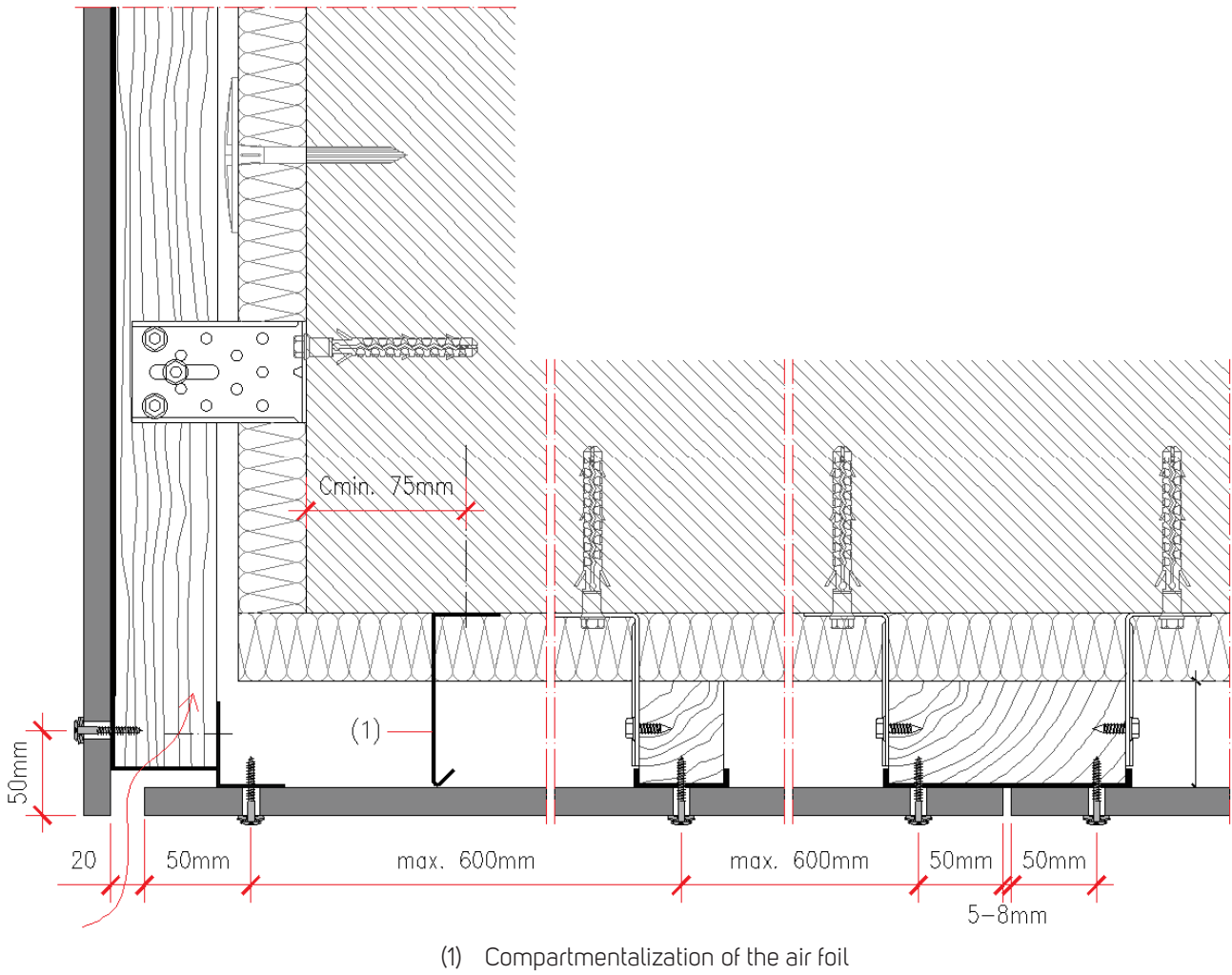

Figure 2.3.43 - Detail of the façade - false ceiling connection

2.1.42 Details, galvanised steel frame

Figures 2.3.44 to 2.3.59 show examples of various details and unique areas of the façade.

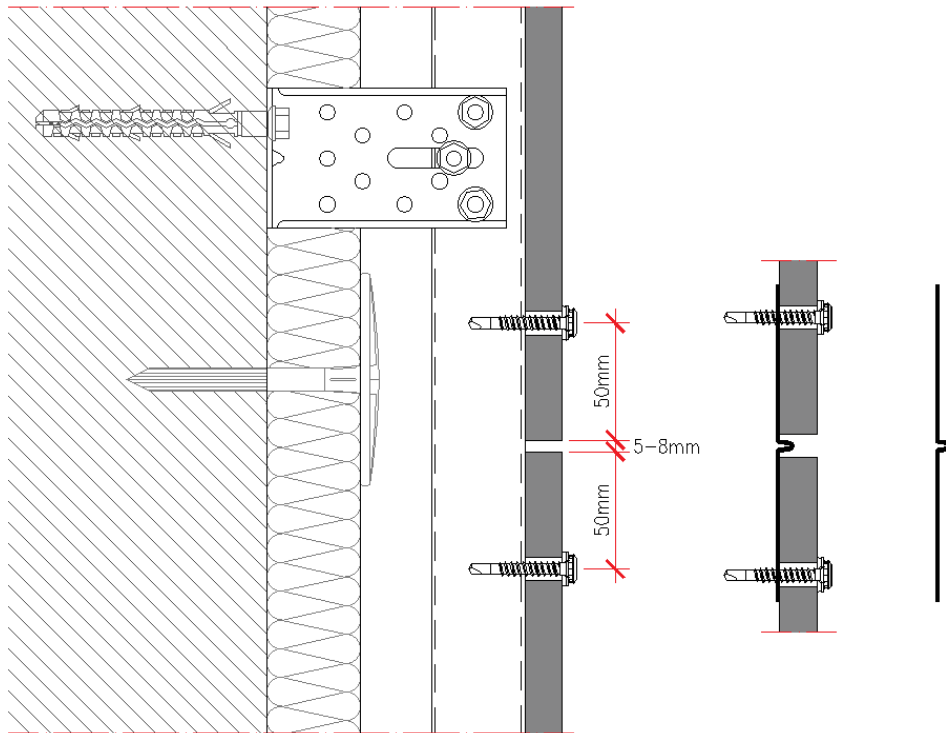

Figure 2.3.44 - Vertical section, joint between panels

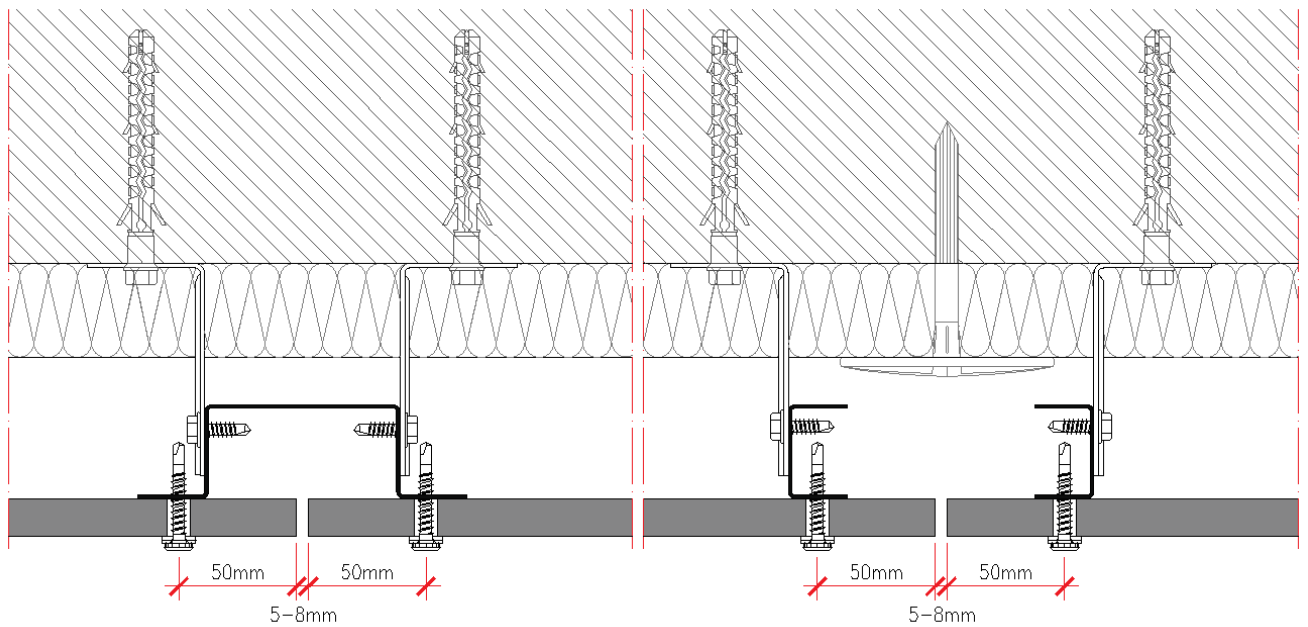

Figure 2.3.45 - Horizontal section, joint between panels

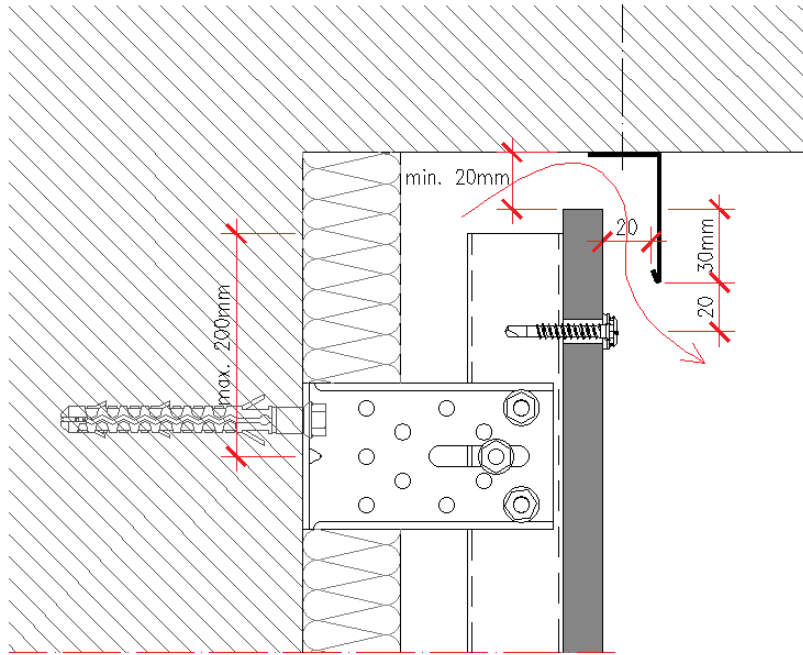

Figure 2.3.46 - Balcony finish

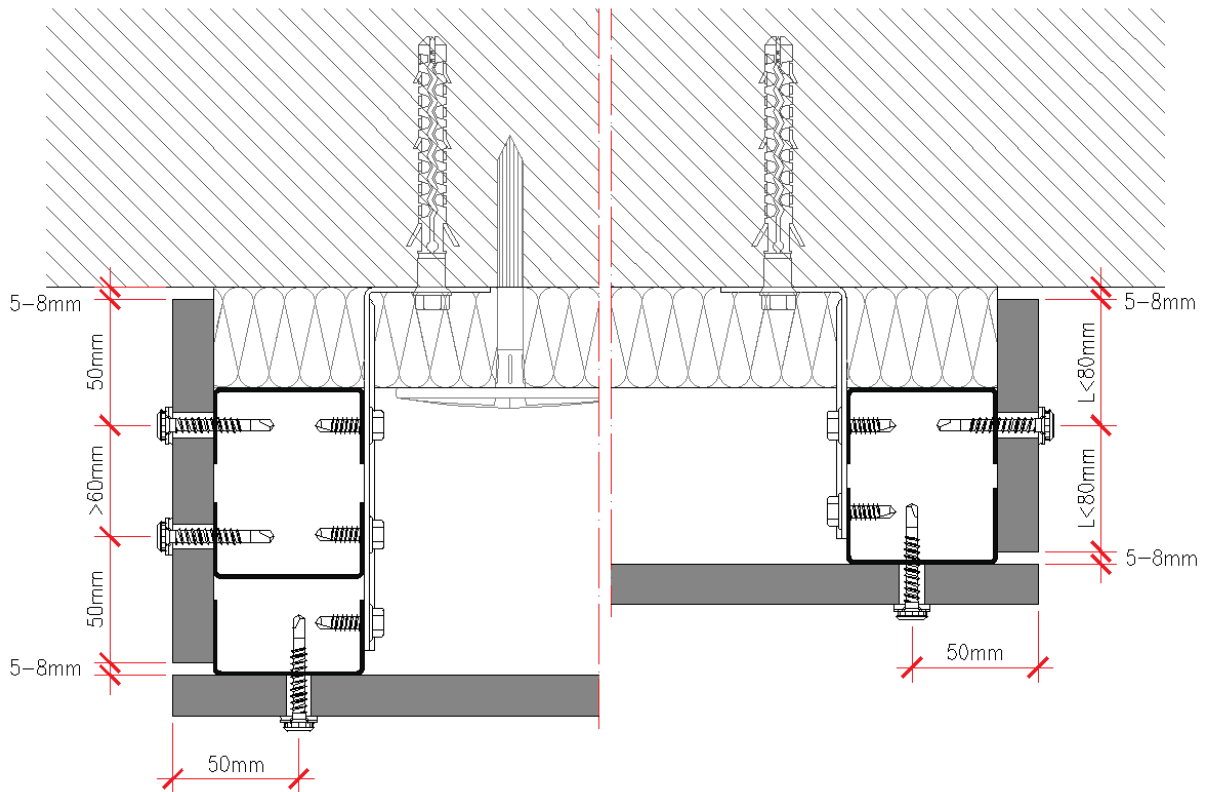

Figure 2.3.47 - Side finish

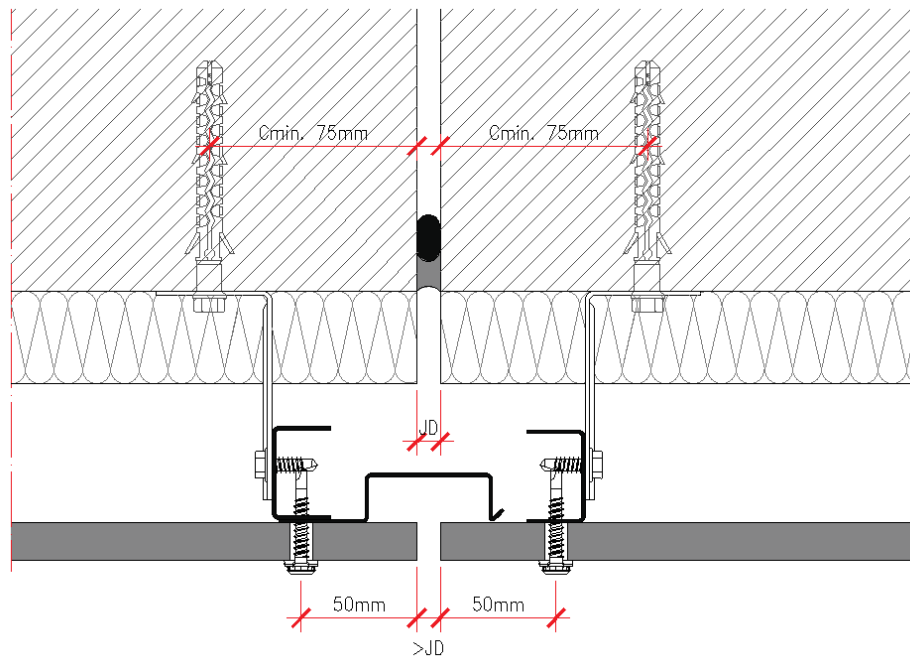

Figure 2.3.48 - JD-Expansion joint

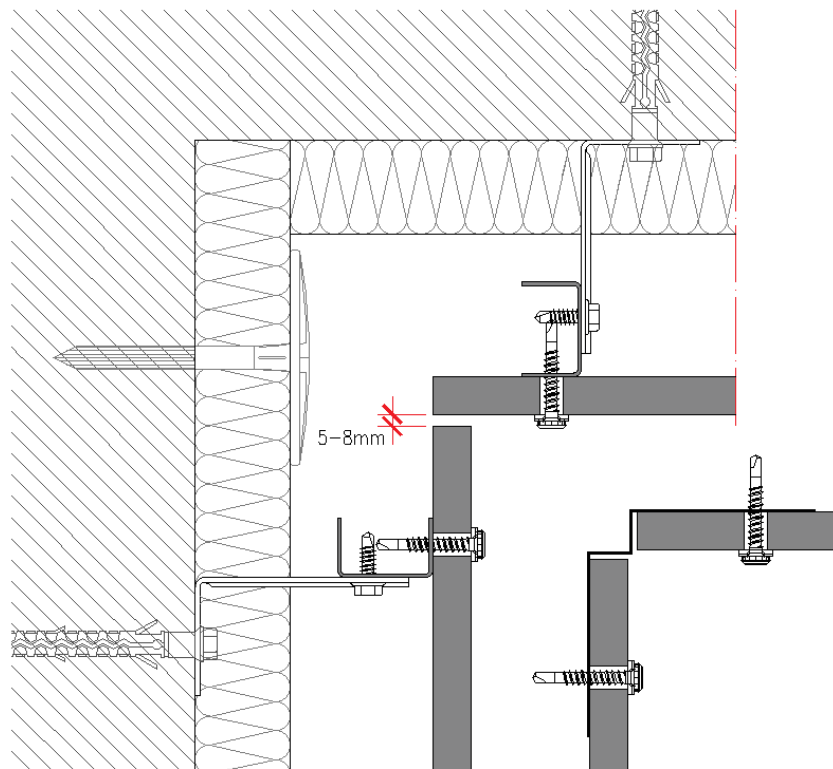
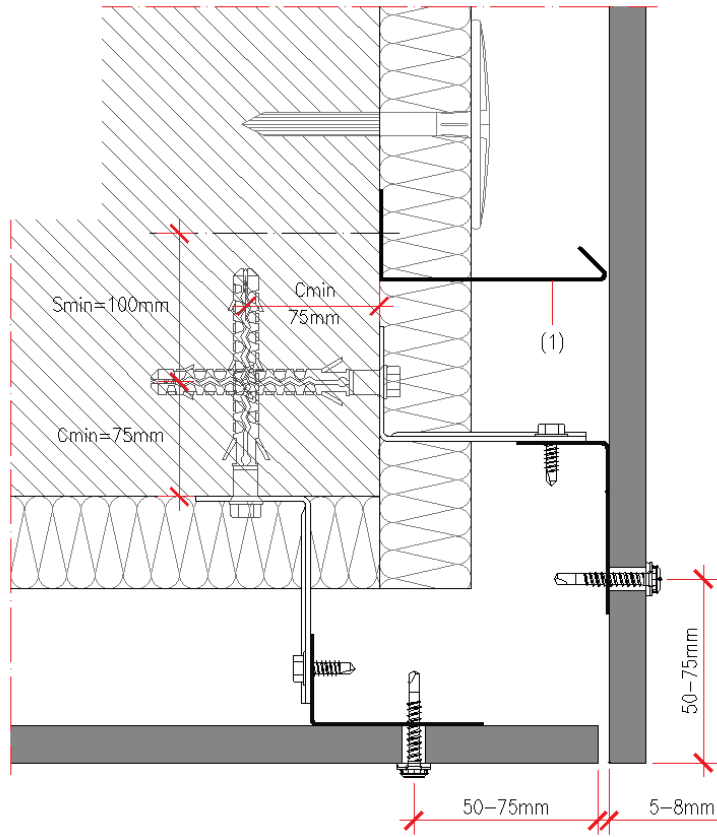
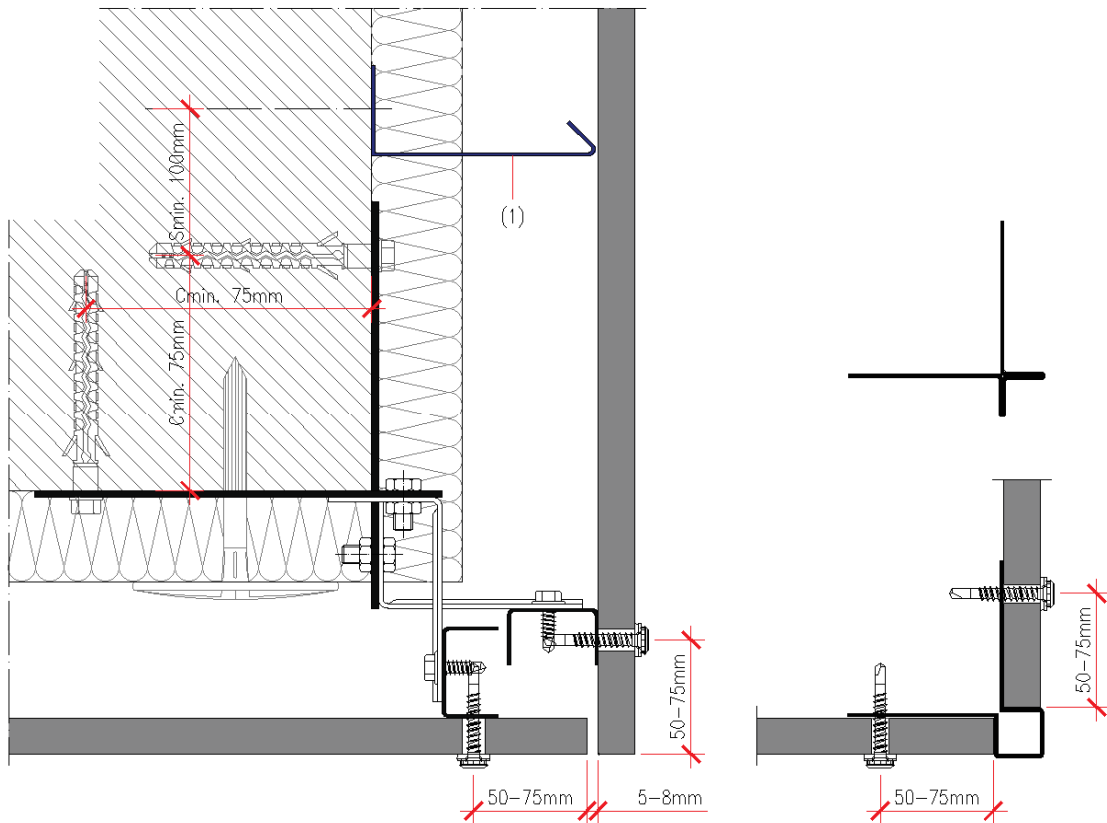

Figure 2.3.49 - Corner angle



(1) Compartmentalisation of the air foil
Figure 2.3.50 - Corner angle



(1) Compartmentalisation of the air foil
Figure 2.3.51 - Corner angle, variant

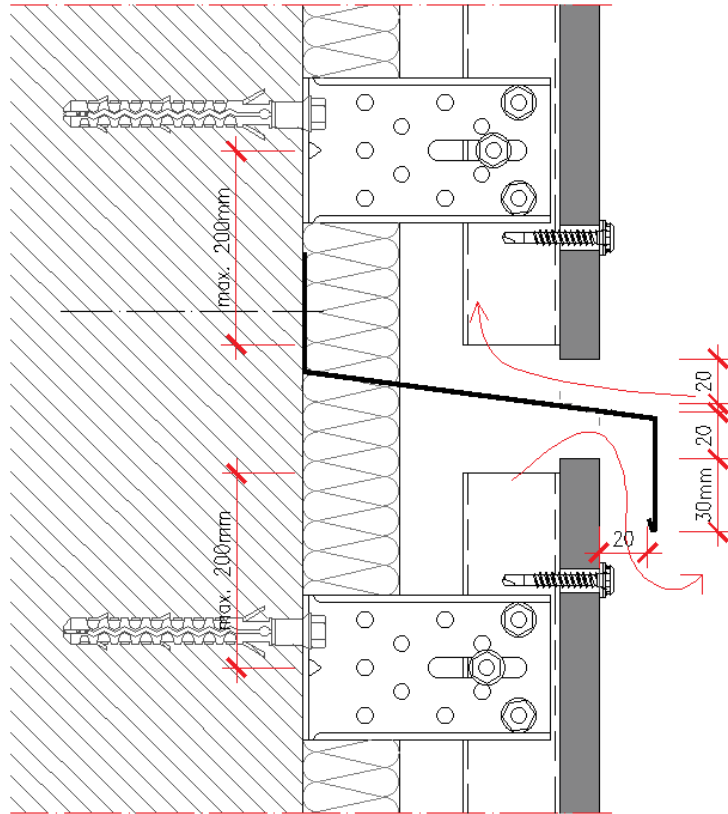

Figure 2.3.52 - Horizontal compartmentalisation of the air gap

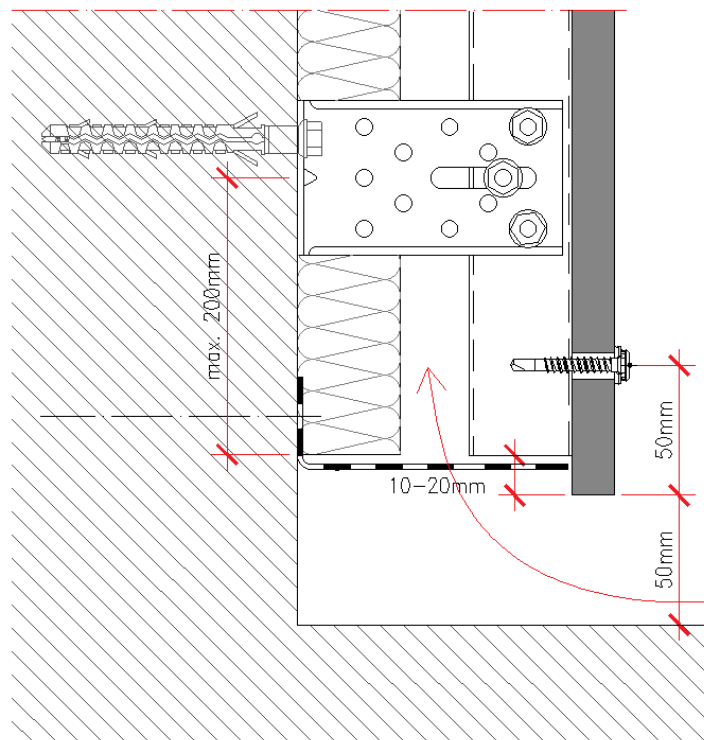

Figure 2.3.53 - Detail of the base, anti-rodent grid

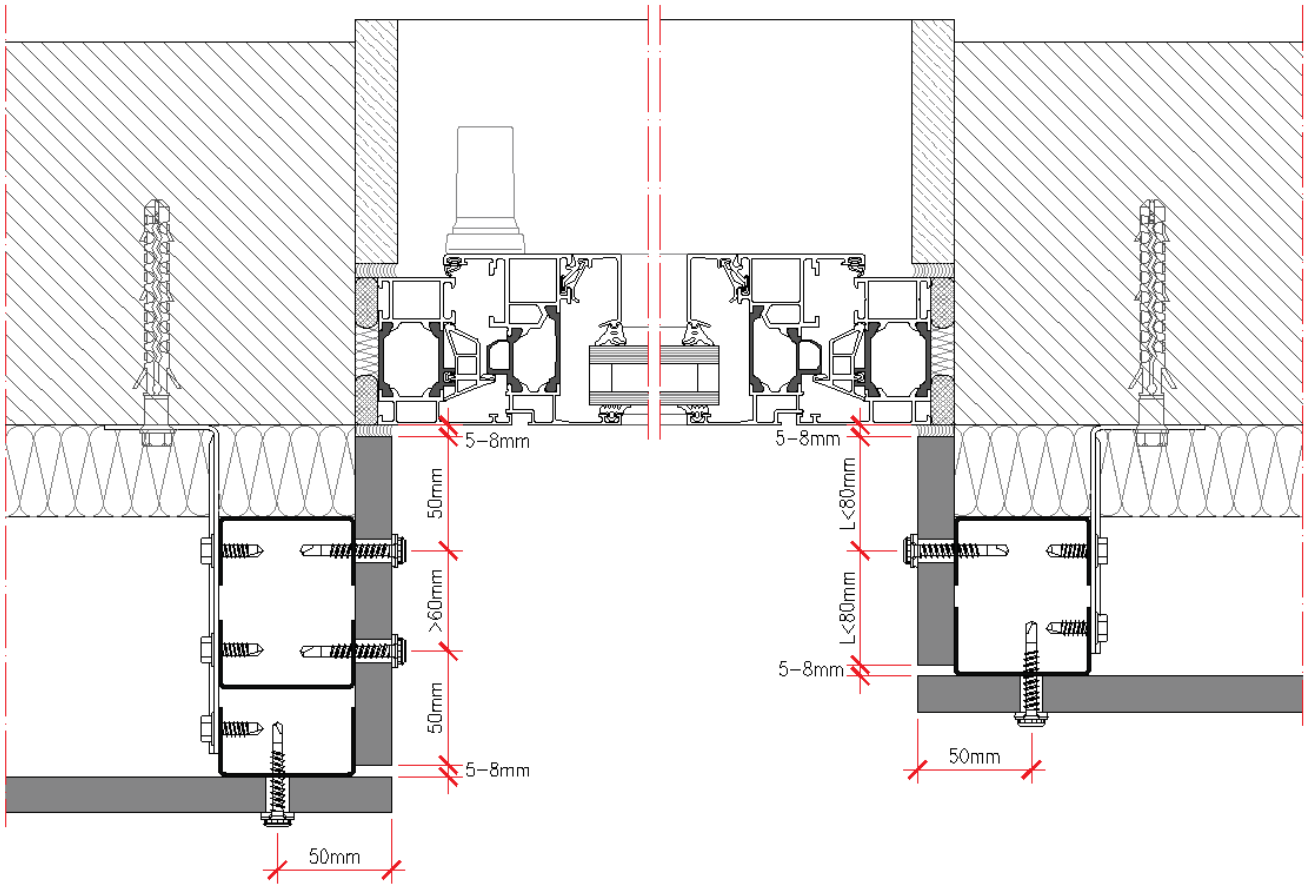

Figure 2.3.54 - Horizontal section, window opening

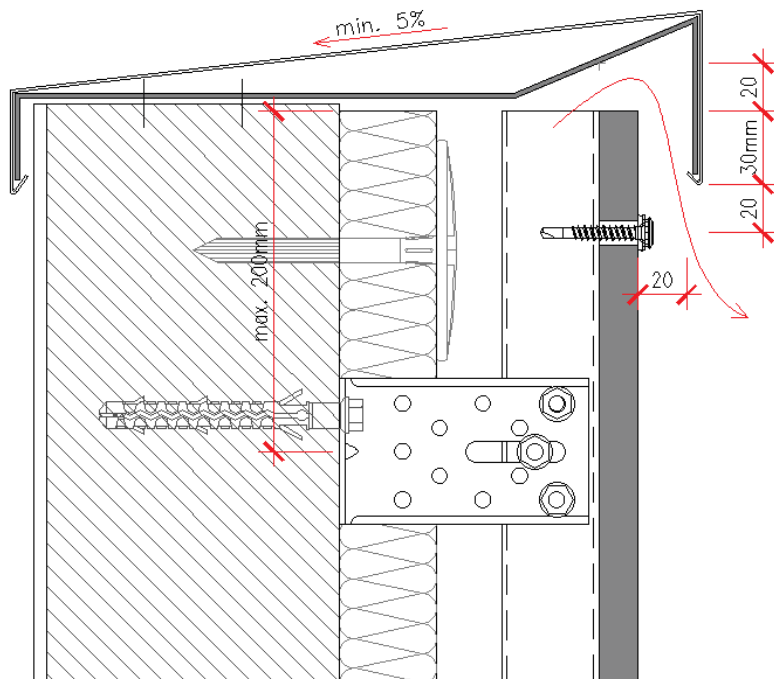

Figure 2.3.55 - Detail of the top

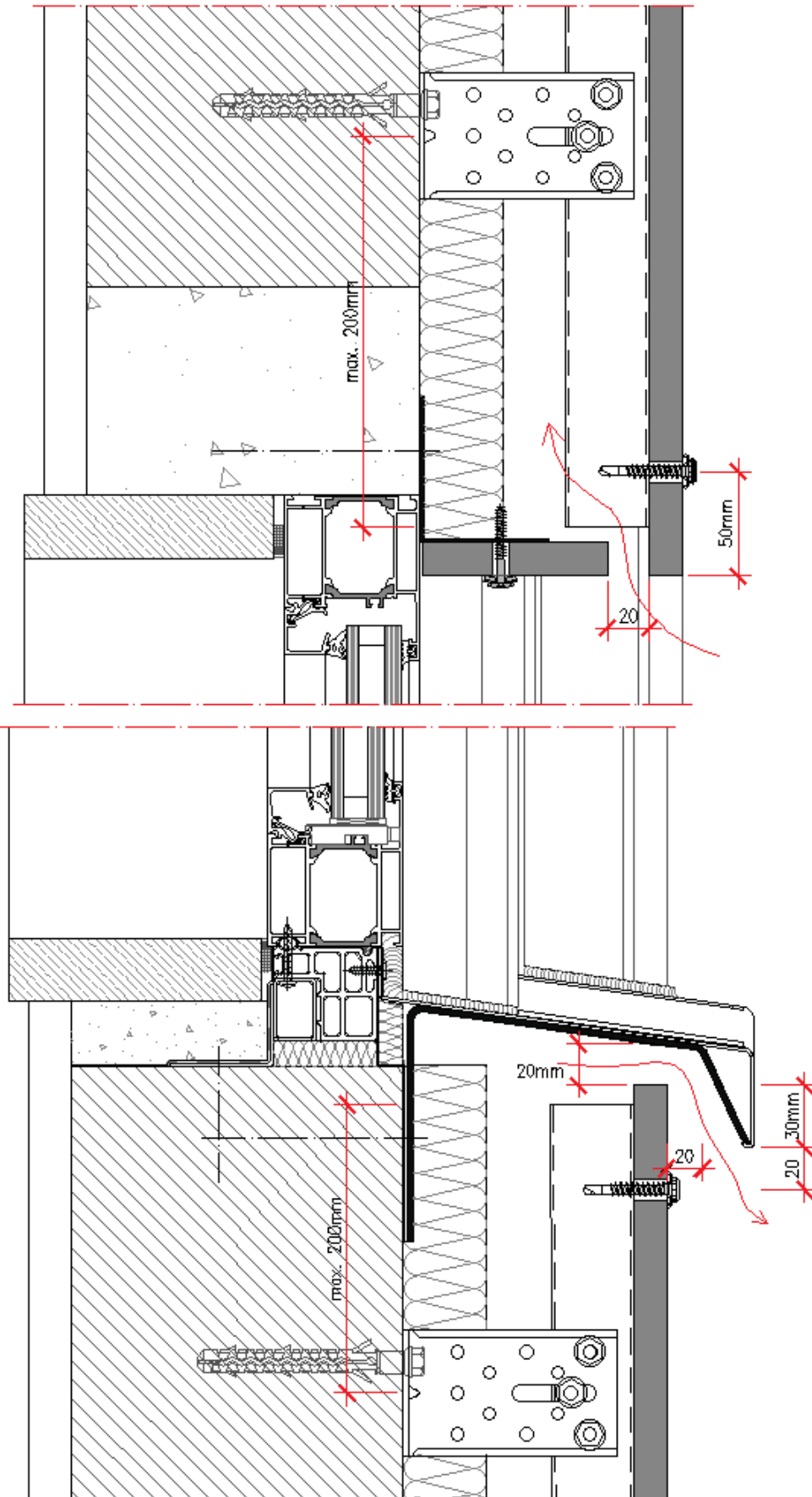

Figure 2.3.56 - Vertical section, window opening

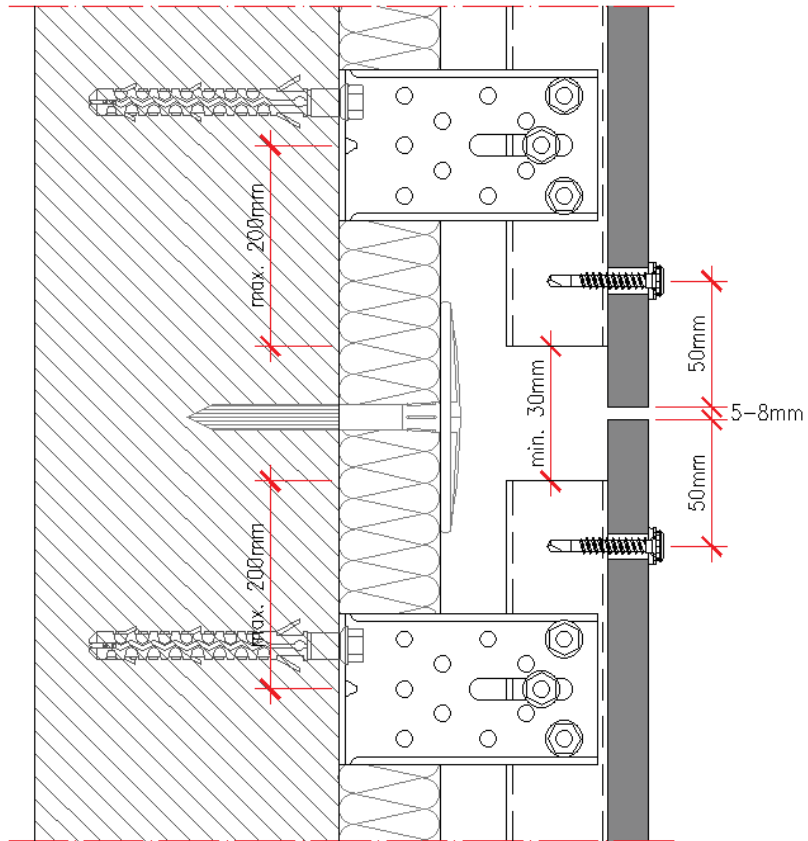

Figure 2.3.57 - Fractioning the structure: Profiles with length ≤ 6 m

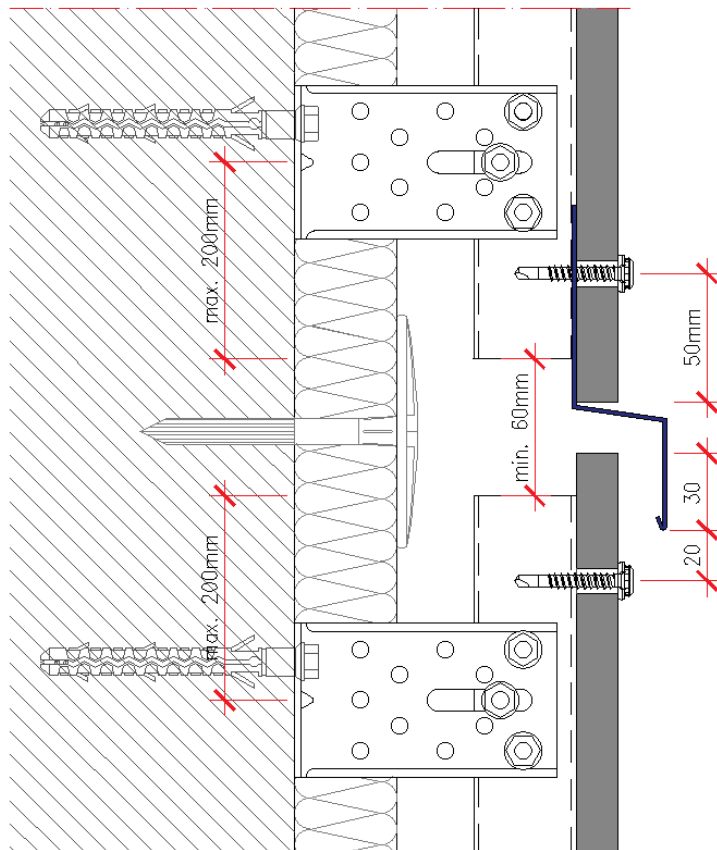
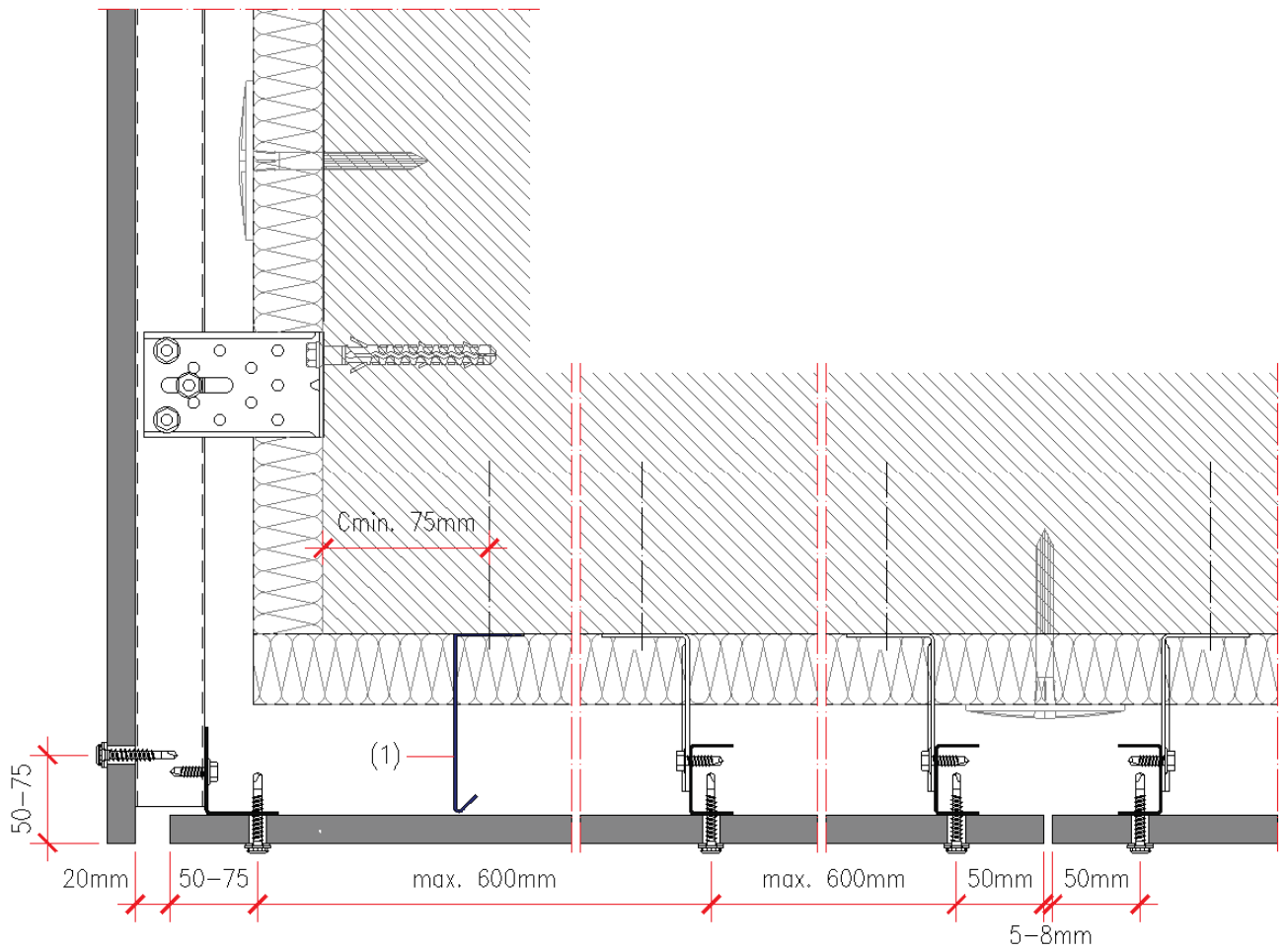

Figure 2.3.58 - Fractionation of the structure: Profiles with length > 6 m



(1) Compartmentalisation of the air foil

Figure 2.3.59 - Detail of the façade - false ceiling connection

WIND LOAD TABLES

Maximum pressure on the panels when subjected to wind action (suction), N>3

Horizontal distance between screws 300 mm (12")											
Thickness of panel	(H x V)	Vertical distance between screws									
		300 mm	12"	400 mm	16"	500 mm	20"	600 mm	24"	700 mm	28"
		kN/m ²	psf	kN/m ²	psf	kN/m ²	psf	kN/m ²	psf	kN/m ²	psf
12 mm 1/2"	2 x 2	3,7	78	3,0	62	2,0	42	1,4	29	1,0	21
	2 x 3	3,4	71	2,6	53	2,0	43	1,7	36	1,5	30
	2 x N	3,4	71	2,6	53	2,0	43	1,7	36	1,5	30
	3 x 2	3,4	71	2,7	57	2,0	42	1,4	29	1,0	21
	N x 2	3,4	71	2,7	57	2,0	42	1,4	29	1,0	21
	3 x 3	3,1	64	2,3	48	1,8	39	1,5	32	1,3	28
	3 x N	3,1	64	2,3	48	1,8	39	1,5	32	1,3	28
	N x 3	3,1	64	2,3	48	1,8	39	1,5	32	1,3	28
16 mm 5/8"	2 x 2	7,8	163	6,2	130	4,7	99	3,3	69	2,4	50
	2 x 3	7,2	150	5,4	113	4,3	90	3,6	75	3,1	64
	2 x N	7,2	150	5,4	113	4,3	90	3,6	75	3,1	64
	3 x 2	7,2	150	5,8	120	4,7	99	3,3	69	2,4	50
	N x 2	7,2	150	5,8	120	4,7	99	3,3	69	2,4	50
	3 x 3	3,4	71	2,5	53	2,0	43	1,7	35	1,5	30
	3 x N	3,4	71	2,5	53	2,0	43	1,7	35	1,5	30
	N x 3	3,4	71	2,5	53	2,0	43	1,7	35	1,5	30

Table 1 – Maximum pressure, 300 mm spacing between screws horizontally

Horizontal distance between screws 400 mm (16")											
Thickness of panel	(H x V)	Vertical distance between screws									
		300 mm	12"	400 mm	16"	500 mm	20"	600 mm	24"	700 mm	28"
		kN/m ²	psf	kN/m ²	psf	kN/m ²	psf	kN/m ²	psf	kN/m ²	psf
12 mm 1/2"	2 x 2	3,0	62	2,4	50	2,0	42	1,4	29	1,0	21
	2 x 3	2,7	57	2,0	43	1,6	34	1,4	28	1,2	24
	2 x N	2,7	57	2,0	43	1,6	34	1,4	28	1,2	24
	3 x 2	2,6	53	2,0	43	1,7	36	1,4	29	1,0	21
	N x 2	2,6	53	2,0	43	1,7	36	1,4	29	1,0	21
	3 x 3	2,3	48	1,7	36	1,4	29	1,2	24	1,0	21
	3 x N	2,3	48	1,7	36	1,4	29	1,2	24	1,0	21
	N x 3	2,3	48	1,7	36	1,4	29	1,2	24	1,0	21
16 mm 5/8"	2 x 2	6,2	130	5,0	104	4,2	87	3,3	69	2,4	50
	2 x 3	5,8	120	4,3	90	3,5	72	2,9	60	2,5	52
	2 x N	5,8	120	4,3	90	3,5	72	2,9	60	2,5	52
	3 x 2	5,4	113	4,3	90	3,6	75	3,1	64	2,4	50
	N x 2	5,4	113	4,3	90	3,6	75	3,1	64	2,4	50
	3 x 3	2,5	53	1,9	40	1,5	32	1,3	27	1,1	23
	3 x N	2,5	53	1,9	40	1,5	32	1,3	27	1,1	23
	N x 3	2,5	53	1,9	40	1,5	32	1,3	27	1,1	23

Table 2 - Maximum pressure, 400 mm spacing between screws horizontally

Horizontal distance between screws 500 mm (20")											
Thickness of panel	(H x V)	Vertical distance between screws									
		300 mm	12"	400 mm	16"	500 mm	20"	600 mm	24"	700 mm	28"
		kN/m ²	psf	kN/m ²	psf	kN/m ²	psf	kN/m ²	psf	kN/m ²	psf
12 mm 1/2"	2 x 2	2,0	42	2,0	42	1,7	35	1,4	29	1,0	21
	2 x 3	2,0	42	1,7	36	1,4	28	1,1	24	1,0	20
	2 x N	2,0	42	1,7	36	1,4	28	1,1	24	1,0	20
	3 x 2	2,0	43	1,6	34	1,4	28	1,2	24	1,0	21
	N x 2	2,0	43	1,6	34	1,4	28	1,2	24	1,0	21
	3 x 3	1,8	39	1,4	29	1,1	23	0,9	19	0,8	17
	3 x N	1,8	39	1,4	29	1,1	23	0,9	19	0,8	17
	N x 3	1,8	39	1,4	29	1,1	23	0,9	19	0,8	17
16 mm 5/8"	2 x 2	4,7	99	4,2	87	3,5	72	3,0	62	2,4	50
	2 x 3	4,7	99	3,6	75	2,9	60	2,4	50	2,1	43
	2 x N	4,7	99	3,6	75	2,9	60	2,4	50	2,1	43
	3 x 2	4,3	90	3,5	72	2,9	60	2,5	52	2,2	45
	N x 2	4,3	90	3,5	72	2,9	60	2,5	52	2,2	45
	3 x 3	2,0	43	1,5	32	1,2	26	1,0	21	0,9	18
	3 x N	2,0	43	1,5	32	1,2	26	1,0	21	0,9	18
	N x 3	2,0	43	1,5	32	1,2	26	1,0	21	0,9	18

Table 3 - Maximum pressure, 500 mm spacing between screws horizontally

Horizontal distance between screws 600 mm (24")											
Thickness of panel	(H x V)	Vertical distance between screws									
		300 mm	12"	400 mm	16"	500 mm	20"	600 mm	24"	700 mm	28"
		kN/m ²	psf	kN/m ²	psf	kN/m ²	psf	kN/m ²	psf	kN/m ²	psf
12 mm 1/2"	2 x 2	1,4	29	1,4	29	1,4	29	1,2	25	1,0	21
	2 x 3	1,4	29	1,4	29	1,2	24	1,0	20	0,8	17
	2 x N	1,4	29	1,4	29	1,2	24	1,0	20	0,8	17
	3 x 2	1,7	36	1,4	28	1,1	24	1,0	20	0,9	18
	N x 2	1,7	36	1,4	28	1,1	24	1,0	20	0,9	18
	3 x 3	1,5	32	1,2	24	0,9	19	0,8	16	0,7	14
	3 x N	1,5	32	1,2	24	0,9	19	0,8	16	0,7	14
	N x 3	1,5	32	1,2	24	0,9	19	0,8	16	0,7	14
16 mm 5/8"	2 x 2	3,3	69	3,3	69	3,0	62	2,5	53	2,2	46
	2 x 3	3,3	69	3,1	64	2,5	52	2,1	43	1,8	37
	2 x N	3,3	69	3,1	64	2,5	52	2,1	43	1,8	37
	3 x 2	3,6	75	2,9	60	2,4	50	2,1	43	1,8	38
	N x 2	3,6	75	2,9	60	2,4	50	2,1	43	1,8	38
	3 x 3	1,7	35	1,3	27	1,0	21	0,8	18	0,7	15
	3 x N	1,7	35	1,3	27	1,0	21	0,8	18	0,7	15
	N x 3	1,7	35	1,3	27	1,0	21	0,8	18	0,7	15

Table 4 - Maximum pressure, 600 mm spacing between screws horizontally

Horizontal distance between screws 700 mm (28")											
Thickness of panel	(H x V)	Vertical distance between screws									
		300 mm kN/m ²	12" psf	400 mm kN/m ²	16" psf	500 mm kN/m ²	20" psf	600 mm kN/m ²	24" psf	700 mm kN/m ²	28" psf
12 mm 1/2"	2 x 2	1,0	21	1,0	21	1,0	21	1,0	21	0,9	20
	2 x 3	1,0	21	1,0	21	1,0	21	0,9	18	0,7	15
	2 x N	1,0	21	1,0	21	1,0	21	0,9	18	0,7	15
	3 x 2	1,5	30	1,2	24	1,0	20	0,8	17	0,7	15
	N x 2	1,5	30	1,2	24	1,0	20	0,8	17	0,7	15
	3 x 3	1,3	28	1,0	21	0,8	17	0,7	14	0,6	12
	3 x N	1,3	28	1,0	21	0,8	17	0,7	14	0,6	12
	N x 3	1,3	28	1,0	21	0,8	17	0,7	14	0,6	12
16 mm 5/8"	2 x 2	2,4	50	2,4	50	2,4	50	2,2	46	1,9	41
	2 x 3	2,4	50	2,4	50	2,2	45	1,8	38	1,5	32
	2 x N	2,4	50	2,4	50	2,2	45	1,8	38	1,5	32
	3 x 2	3,1	64	2,5	52	2,1	43	1,8	37	1,5	32
	N x 2	3,1	64	2,5	52	2,1	43	1,8	37	1,5	32
	3 x 3	1,5	30	1,1	23	0,9	18	0,7	15	0,6	13
	3 x N	1,5	30	1,1	23	0,9	18	0,7	15	0,6	13
	N x 3	1,5	30	1,1	23	0,9	18	0,7	15	0,6	13

Table 5 - Maximum pressure, 700 mm spacing between screws horizontally



Technical File

Chapter 3 - Walls and cladding of the interior walls

Cement-bonded particleboards

Office

Lisboa Oriente

Av. Infante Dom Henrique 337, 3rd Floor

1800- 210 LISBON, PORTUGAL

Factory

VIROC Portugal S.A.

National Road 10

Km 44.7, Vale da Rosa

2914-519 SETÚBAL, PORTUGAL

In/ investwood

www.investwood.pt

INDEX

3. Walls	5
3.1 General features	5
3.2 Fasteners	6
3.3 Partition walls	10
3.3.1 Wooden beams	10
3.3.2 Galvanised steel profiles	10
3.4 Wall cladding	12
3.5 Joints between panels	15
3.6 Panel edges	16
3.7 Acoustic insulation	17
3.8 Fire resistance	21
3.9 Special finishes	26

FIGURE INDEX

Figure 3.1 - Location of the screws	6
Figure 3.2 - Galvanised steel screw for wooden structure	6
Figure 3.3 - Galvanised steel screw for metal structure	6
Figure 3.4 - Headless nail	7
Figure 3.5 - Pneumatic nail gun	7
Figure 3.6 - Location of the nails	7
Figure 3.7 - Rivets with aluminium body and stainless steel nail	8
Figure 3.8 - System for bonding panels with mastic	8
Figure 3.9 - VHB double-sided adhesive tape (3M)	9
Figure 3.10 - Dual-Lock adhesive tape (3M)	9
Figure 3.11 - Wooden structure type of section, minimum strength of class C18 (EN 338)	10
Figure 3.12 - Galvanised steel structure type section	11
Figure 3.13 - Horizontal section of the wall, wooden structure	11
Figure 3.14 - Horizontal section of the wall, galvanised steel structure	11
Figure 3.15 - Wall vertical section	12
Figure 3.16 - Wooden section, minimum strength of class C18 (EN338)	13
Figure 3.17 - Omega profile (min. thickness 0.7 mm), galvanised steel DX51D (Z+)	13
Figure 3.18 - Horizontal section of wall cladding, wooden structure	14
Figure 3.19 - Horizontal section of wall cladding, galvanised steel structure	14
Figure 3.20 - Vertical section of wall cladding	15
Figure 3.21 - Joints between panels	16
Figure 3.22 - Joints between panels filled with mastic bead	16
Figure 3.23 - Bevelled machined edges	16
Figure 3.24 - Wall 1+1 with simple structure	17
Figure 3.25 - 2+1 wall with simple structure	18
Figure 3.26 - Wall 2+2 with simple structure	18
Figure 3.27 - Wall 2+1 with double structure	19
Figure 3.28 - Wall 2+2 with double structure	19
Figure 3.29 - 3+1 wall with double structure	20
Figure 3.30 - Wall 3+2 with double structure	20
Figure 3.31 - 3+1+2 wall with double structure	21
Figure 3.32 - EI90 Wall, Horizontal Section	22
Figure 3.33 - EI90 Wall, Vertical Section	23
Figure 3.34 - EI120 Wall, Horizontal Section	24
Figure 3.35 - EI120 Wall, Vertical Section	25

Credits

Author

Mr José Pinheiro Soares,

suporte.tecnico@investwood.pt

Review and English Translation

CS Traduções

geral@cstraducoes.pt

Viroc Portugal S.A. reserves the right to modify this document without prior notice.

This Technical File invalidates all previous technical documents.

Issue: February 15, 2024

3. WALLS

Viroc panels can be used to make interior partition walls or interior wall cladding. When applied to interior partition walls, they can be varnished, painted or unfinished (rough). It is the installer's responsibility to check the security conditions of the support structure, in particular the distance between supports and the width of the supports for correct installation of the panels.

Viroc panels undergo small dimensional variations with changes in relative moisture and temperature. The Viroc panel can be expected to accommodate a maximum dimensional variation of -0.1% (shrinkage) to +0.05% (expansion) in an interior application.

Elements constituting the partition walls and the wall cladding

- Cladding panels;
- Support structure for the panels, which can be made of wood or metal and the respective fixing elements;
- Fasteners: Screws, rivets, nails or adhesives;
- Sound insulation.

3.1 General features

Application

Inside

Thicknesses

10 mm in dry indoor areas;

12 mm in moist interior areas such as bathrooms and kitchens.

Maximum panel size

3000x1250 mm

Any intermediate dimensions obtained by cutting the standard dimension panel are possible.

Panel thickness tolerances

Thickness: 10 mm \pm 0.7 mm; 12 mm \pm 1.0 mm

Cutting tolerances

Length and width: \pm 3 mm

Squareness: \leq 2 mm/m

Edge straightness: \leq 1.5 mm/m

3.2 Fasteners

Depending on the type of structure, the panels can be fixed with screws, nails and rivets or glued with adhesive tapes or polyurethane adhesives (PU mastic).

Screws

The panel must be fixed at the distances shown in figure 3.1.

If the screws are placed too close to the edges, they can cause the panel to break.

Screws for wooden structures must have an anchoring length (depth driven into the wood) of at least 20 mm (see figure 3.2).

When the support structure is made of metal, in addition to the appropriate length of the screw body, the drill tip must be of an appropriate size to pierce the thickness of the metal it will be fastened to (see figure 3.3).

The maximum distance between screws must not exceed 600 mm.

Other types of screws can be used as long as they have the same performance and durability.

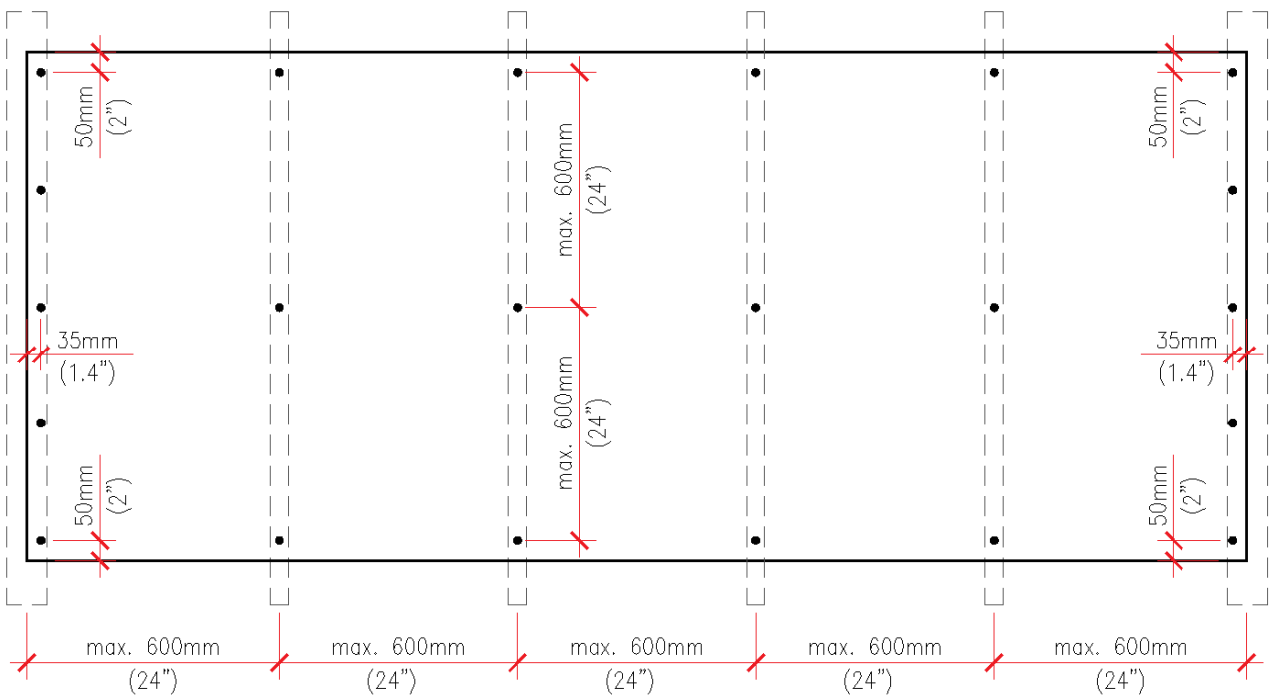

Figure 3.1 - Location of the screws



Figure 3.2 - Galvanised steel screw for wooden structure



Figure 3.3 - Galvanised steel screw for metal structure

Nails

If the structure is made of wood, galvanised steel or stainless steel nails can be used to fix the panels to the structure.

There are headless nails that are practically invisible, as shown in figure 3.4.

The nails should be applied using a suitable pneumatic gun (see figure 3.5). Before the final fixing of the panels begins, a series of tests must be carried out to set the right pressure and force for the nails to be driven in correctly.

When fixing with nails, the distance between fixings must not exceed 600 mm in the horizontal direction and 400 mm in the vertical direction (see figure 3.6).



Figure 3.4 - Headless nail



Figure 3.5 - Pneumatic nail gun

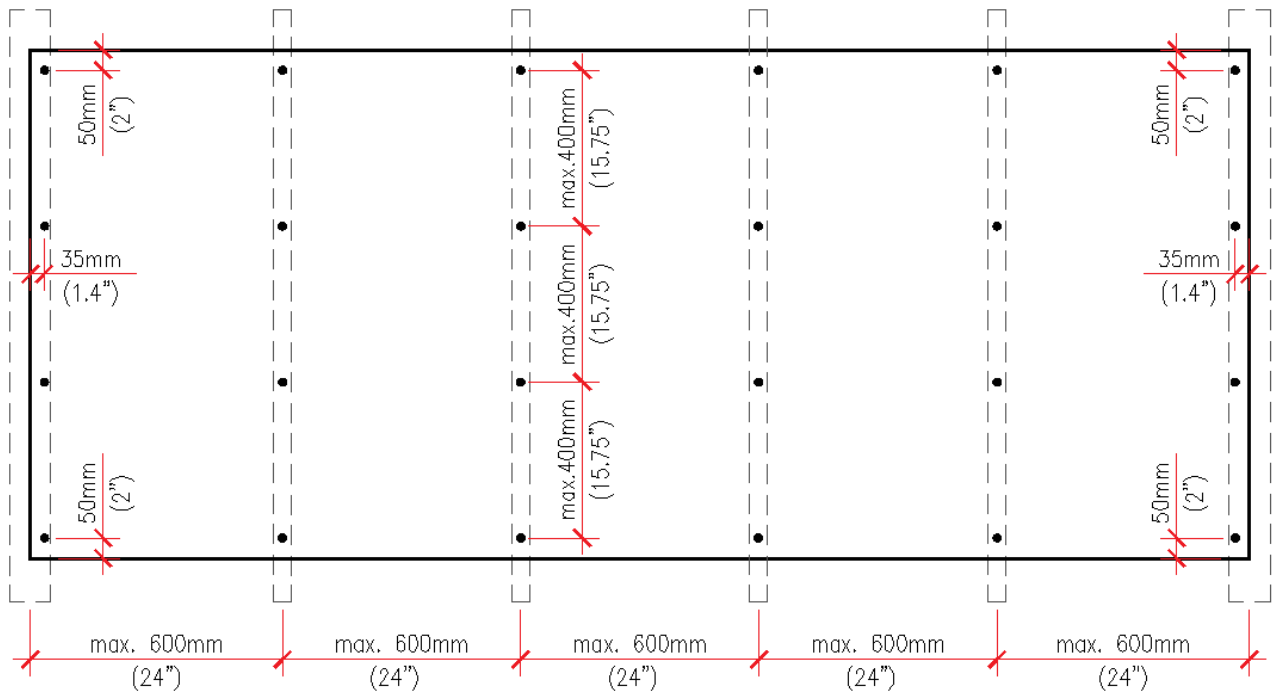

Figure 3.6 - Location of the nails

Rivets

If the structure is made of metal, rivets with an aluminium body and a stainless steel nail can be used to attach the panels to the structure (see figure 3.7).

Rivets can be applied with a manual, electric or compressed air riveting machine.



Figure 3.7 - Rivets with aluminium body and stainless steel nail.

The location of the rivets when fixing the panels should be as shown in figure 3.1, respecting the distances shown.

Mastic adhesives

Mastic bonding systems can be used to bond Viroc panels to wooden and metal structures. This type of fixing consists of:

- Adhesion primer for the support structure;
- Adhesion primer for the Viroc panel;
- Double-sided adhesive tape;
- Mastic adhesive.

The adhesive tape is 3 mm thick and its function is to fix the panels while the mastic adhesive is fresh, i.e. without resistance. This ensures that the cord is 3 mm thick without being crushed.

Sika and Bostik have mastic adhesives suitable for this application. The manufacturers of these materials should always be consulted for advice and correct application (see figure 3.8).



Figure 3.8 - System for bonding panels with mastic

VHB adhesive tape

A variant of the mastic bonding system is the use of VHB double-sided adhesive tape (see figure 3.9).

The tape must be applied according to the manufacturer's instructions so that it adheres to the surfaces without peeling off.



Figure 3.9 - VHB double-sided adhesive tape (3M)

Dual-Lock adhesive tape

For panels that need to be removable, they can be fixed with a 3M Dual-Lock adhesive tape (see figure 3.10). The tape must be applied according to the manufacturer's instructions so that it adheres to the surfaces without peeling off.



Figure 3.10 - Dual-Lock adhesive tape (3M)

3.3 Partition walls

Support structure

3.3.1 Wooden beams

The profiles supporting the panels can be made of pine wood. The strength of the wood used to make up the uprights must be at least of class C18 according to EN 338 and durability of class 2, 3 or higher according to EN 335.

When assembled on site, wooden uprights must not have a moisture level of more than 18%, with a difference between the consecutive elements of no more than 4%. The relative moisture of the wooden uprights is determined according to the method described in standard EN 13183-2, using a tip moisture metre.

The cross-section of the support profiles is generally rectangular, with a minimum dimension of 40x50 mm (see figure 3.11).

The design of these elements takes into account the deformations caused by the actions (self-weight, overloads, etc.), so that they do not jeopardise the normal functioning of the wall. Deformation due to action must not exceed the limit $L/200$ of the span between the support fixings.

The width of the uprights must be such that the fixings can be positioned correctly, with the capacity to absorb small positioning errors, and the screws must not be less than 15 mm from the end of the upright.

Other types of sections can be used, as long as they have the same performance and durability.

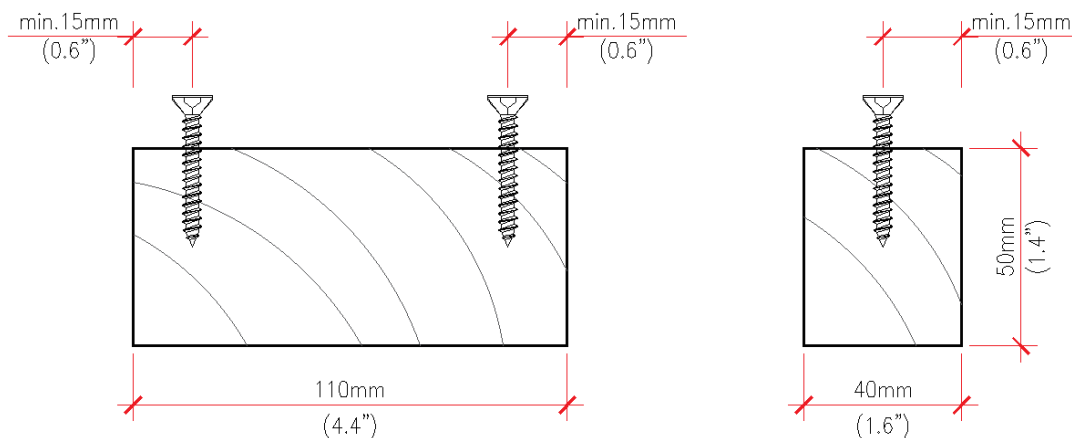

Figure 3.11 – Wooden structure type of section, minimum strength of class C18 (EN 338).

3.3.2 Galvanised steel profiles

The profiles supporting the panels can be made of galvanised steel. The minimum strength of the steel used in the upright profiles must be of class DX51D, in accordance with standard EN 10346.

The hot-dip zinc coating (Z) should be 275 g/m² in coastal areas and 140 g/m² in other areas.

The sections are generally C and U-shaped with a minimum thickness of 0.7 mm. Other profile shapes can be used, as long as they have the same performance and durability (see figure 3.12).

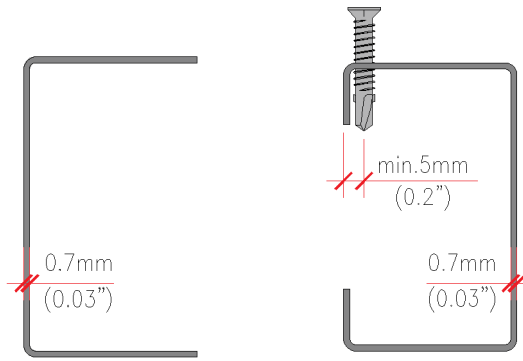

Figure 3.12 - Galvanised steel structure type section

The support structure must be wide enough to allow the fixings to be positioned correctly, respecting the minimum distances between the screws and the edge of the panels. It must also have the capacity to absorb small positioning errors.

Note that in the joint area between panels, when the structure is made of galvanised steel, it is normal to double the profiles in order to respect the distance between the screws and the edges.

The maximum distance between the axes of the supporting elements is 625 mm, and their alignment must be checked between adjacent elements and must not differ by more than 5 mm.

These elements are designed taking into account the deformations caused by their use, so that they do not jeopardise the normal functioning of the wall. The deformation must not exceed the L/300 limit of the span between the supports of these elements.

If less than the recommended thickness of steel is used, the profile used must guarantee the deformation limits indicated above and a good anchorage of the screws. The screws must be suitable for the structure used.

Horizontal section

Figures 3.13 and 3.14 show the horizontal sections of wooden and galvanised steel partition walls, respectively.

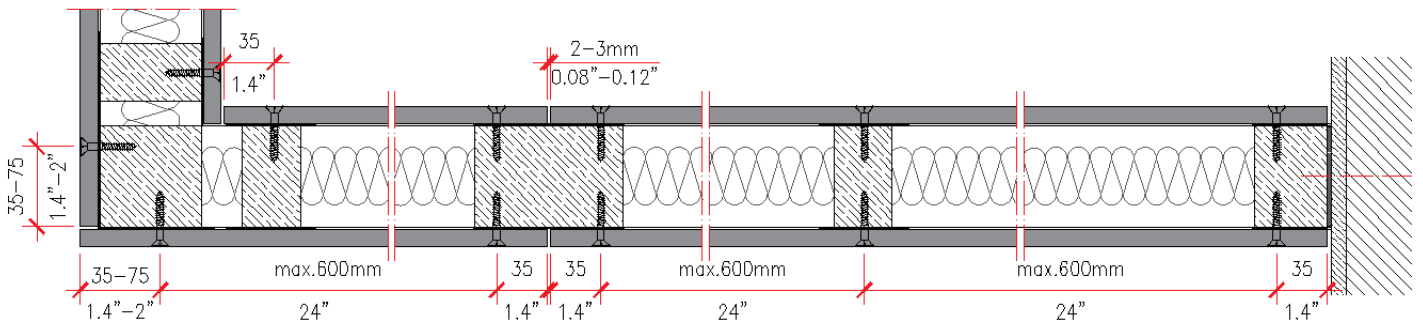

Figure 3.13 - Horizontal section of the wall, wooden structure

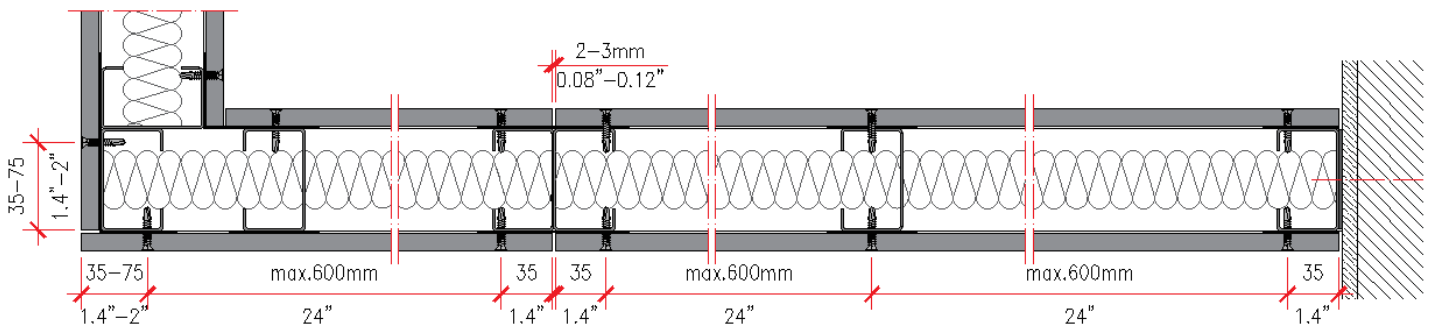

Figure 3.14 - Horizontal section of the wall, galvanised steel structure

Figure 3.15 shows a vertical section of a wooden and galvanised steel structure.

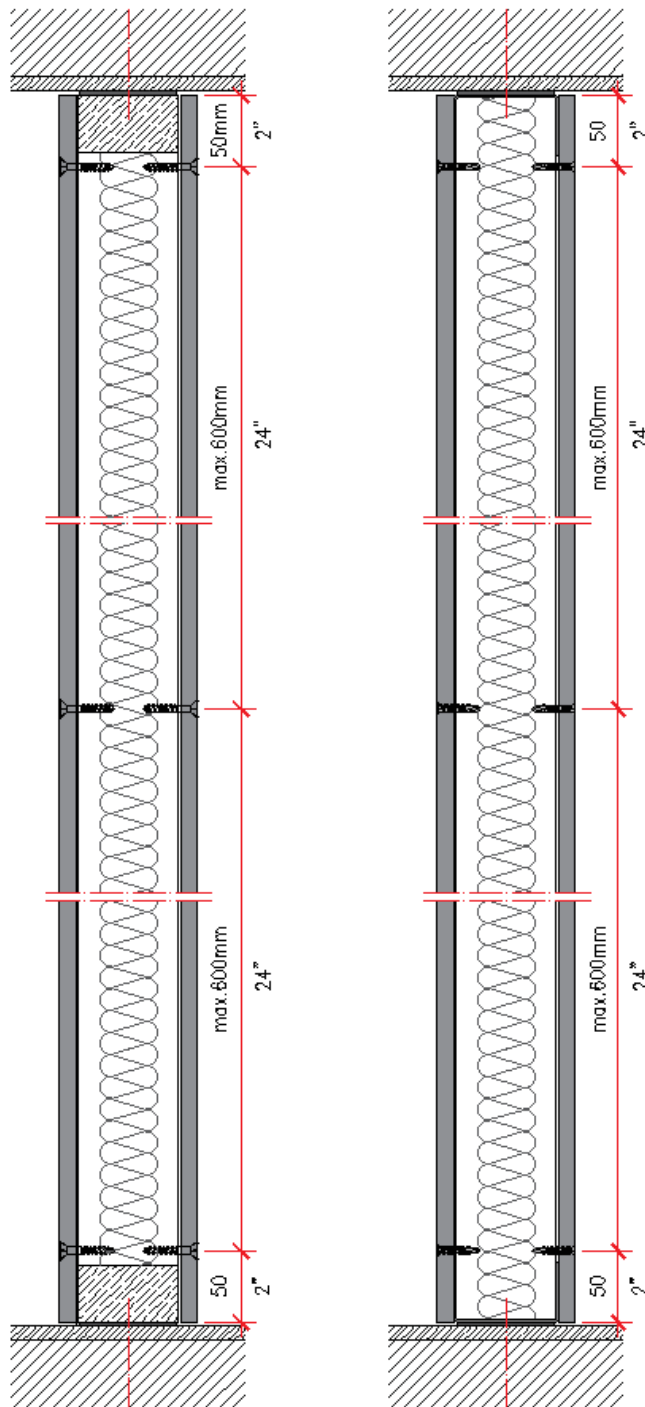

Figure 3.15 - Wall vertical section
Wooden and galvanised steel structure

3.4 Wall cladding

Support structure

The supporting structure of a wall cladding can be made of wooden profiles or galvanised steel. Figures 3.16 and 3.17 show the standard sections of the profiles used. Other profiles can be used, as long as they have the same strength and durability.

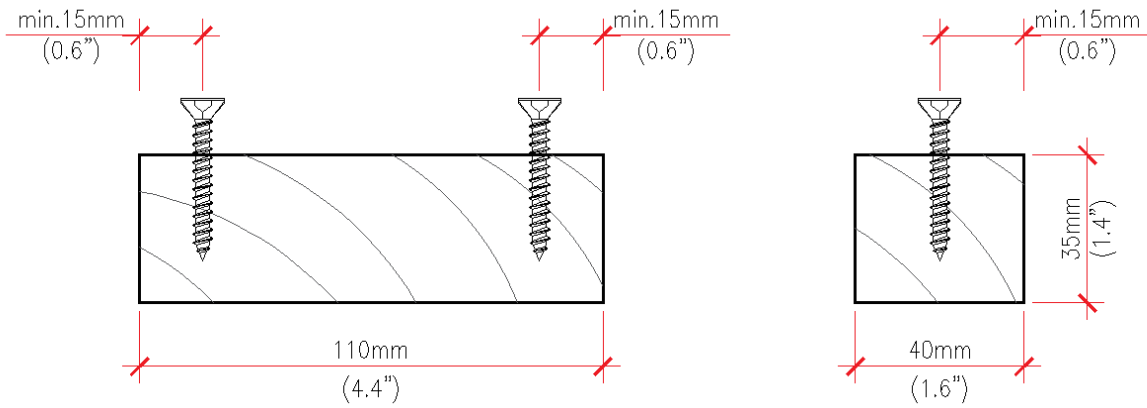

Figure 3.16 - Wooden section, minimum strength of class C18 (EN338)

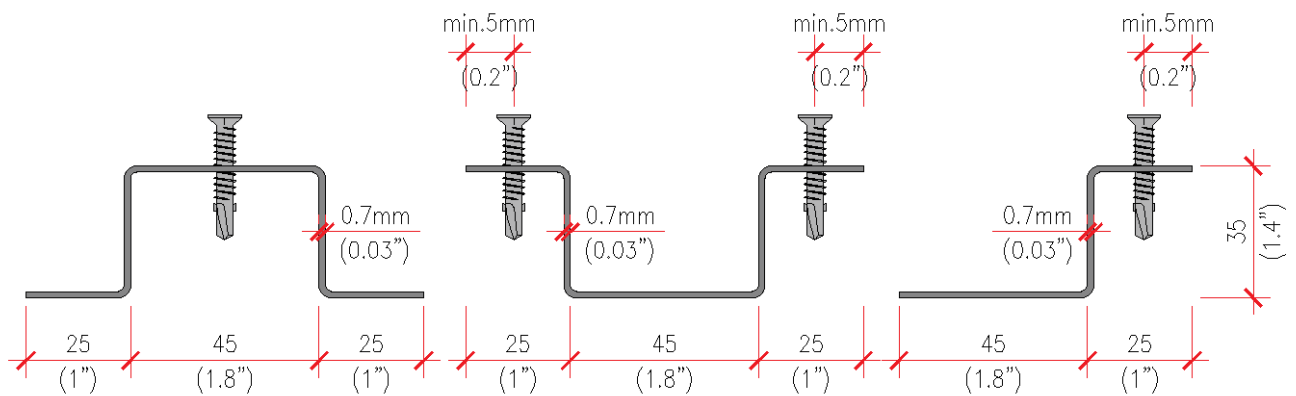

Figure 3.17 - Omega profile (min. thickness 0.7 mm), galvanised steel DX51D (Z+)

The structure that will support the Viroc panels must be aligned and properly positioned. If the wall to be clad is very misaligned, it may be necessary to straighten the supporting structure using supporting squares, forming a structure identical to the one of the ventilated façade.

The support structure must be wide enough to allow the fixings to be positioned correctly, respecting the minimum distances between the screws and the edge of the panels, and have the capacity to absorb small positioning errors.

The maximum distance between the axes of the supporting elements will be 625 mm, and their alignment must be checked between adjacent elements and must not differ by more than 5 mm.

In a wooden support structure, according to EN 338, the Resistance Class is of at least C18.

In a galvanised steel structure, and in accordance with EN 10327, the profile class is of at least DX51D (Z+) and the minimum thickness of the steel sheet is 0.7 mm.

These elements are designed taking into account the deformations caused by their use, so that they do not jeopardise the normal functioning of the wall. The deformation must not exceed the L/300 limit of the span between the supports of these elements.

If less than the recommended thickness of steel is used, the profile used must guarantee the deformation limits indicated above and a good anchorage of the screws. The screws must be suitable for the structure used.

Horizontal section

Figures 3.18 and 3.19 show horizontal sections of wooden and galvanised steel partition walls, respectively.

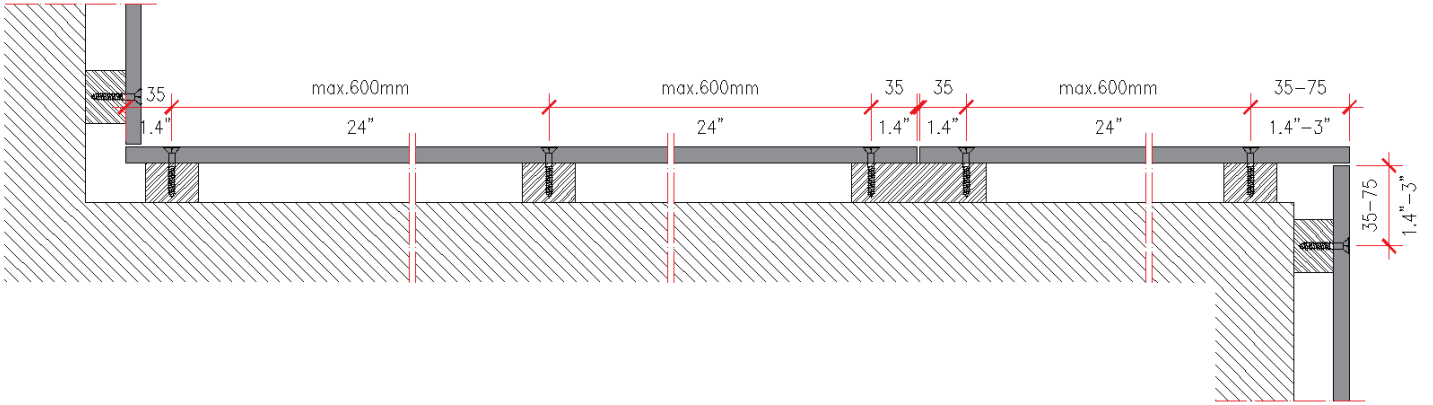

Figure 3.18 - Horizontal section of wall cladding, wooden structure

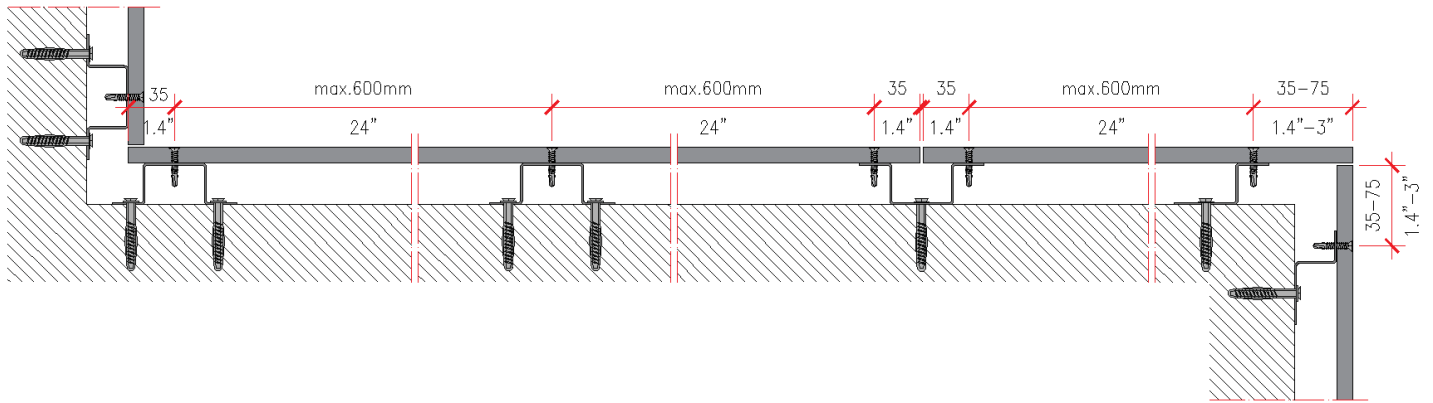

Figure 3.19 - Horizontal section of wall cladding, galvanised steel structure

Figure 3.20 shows a vertical section of a wooden and galvanised steel structure.

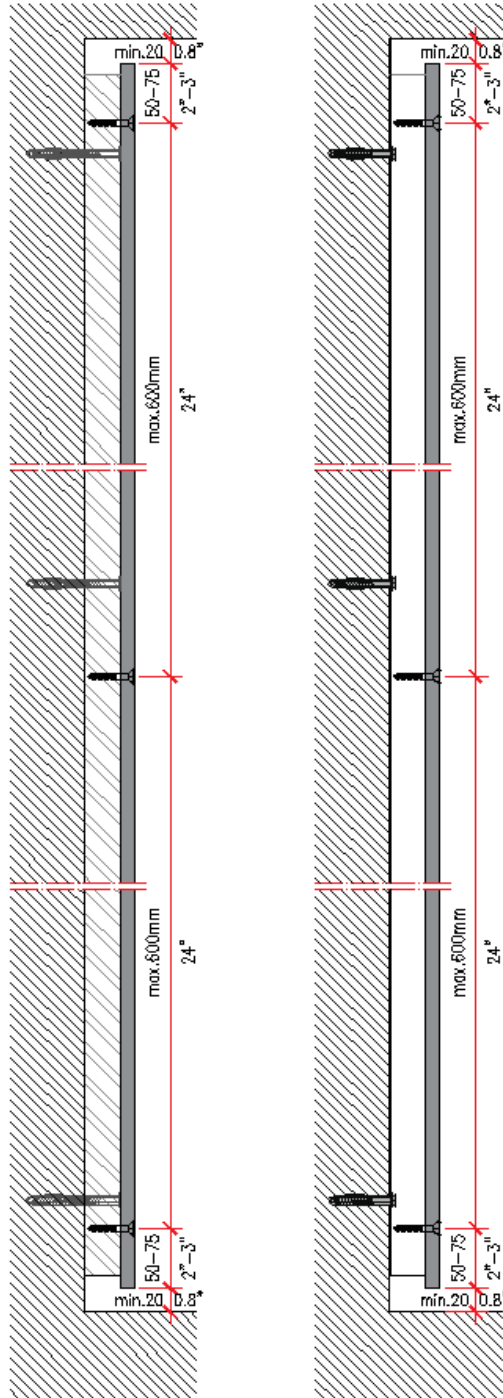

Figure 3.20 - Vertical section of wall cladding
Wooden and galvanised steel structure

3.5 Joints between panels

The joints between panels must have a gap of 2 to 3 mm and can be filled with a silicone bead or mastic (see figures 3.21 and 3.22).

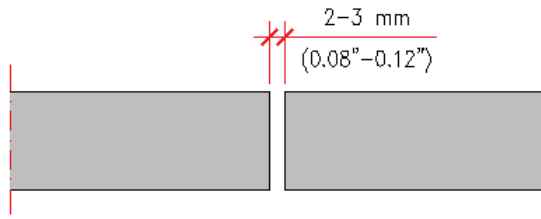

Figure 3.21 - Joints between panels

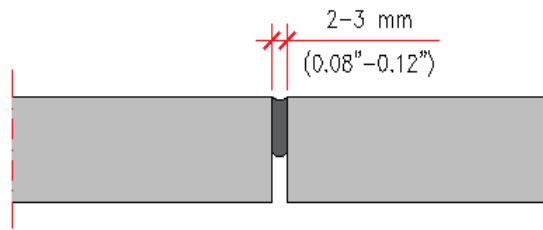

Figure 3.22 - Joints between panels filled with mastic

3.6 Panel edges

The edges of the panels can be machined in a 2 to 3 mm bevel shape (see figure 3.23).

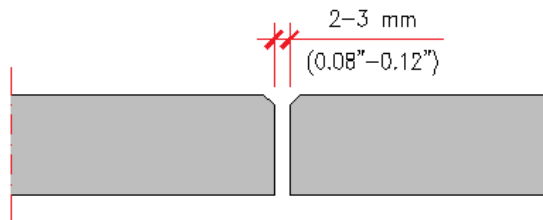

Figure 3.23 - Bevelled machined edges

3.7 Acoustic insulation

Viroc Portugal has several partition wall solutions made with Viroc panels, which have been experimentally characterised in terms of their acoustic performance.

Figures 3.24 to 3.31 show the wall configurations tested and the results obtained, in particular the sound insulation index for airborne sounds R_w according to ISO 140-3.

Wall	Structure		$R_w(C;Ctr)$ [dB]	Representation
1+1	Simple	C90	47(-4;-11)	Figure 3.23
2+1	Simple	C90	47(-1;-1)	Figure 3.24
2+2	Simple	C90	55(-1;-5)	Figure 3.25
2+1	Double	C70+40+C70	59(-3;-11)	Figure 3.26
2+2	Double	C70+40+C70	62(-2;-7)	Figure 3.27
3+1	Double	C70+40+C70	61(-4;-11)	Figure 3.28
3+2	Double	C70+40+C70	64(-2;-7)	Figure 3.29
3+1+2	Double	C70+40+C70	65(-2;-7)	Figure 3.30

1+1 wall with simple structure

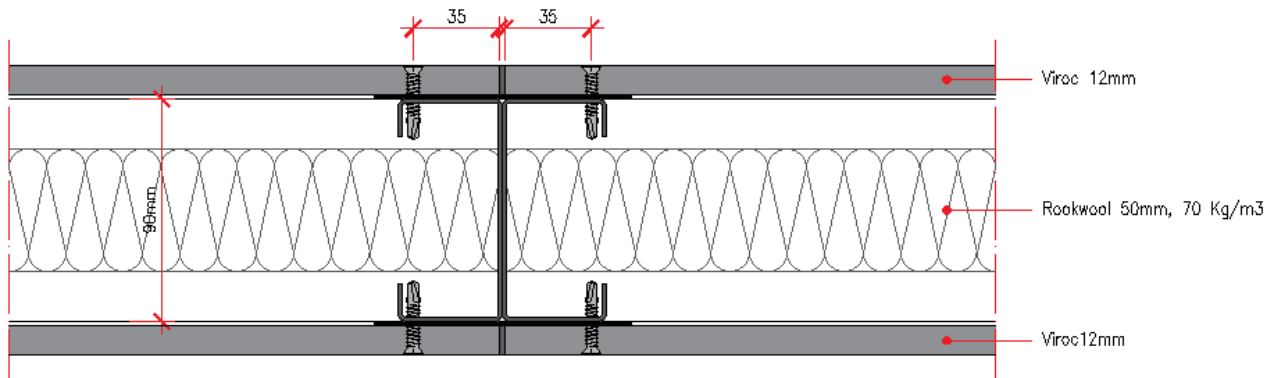

$R_w(C;Ctr) = 47(-4;-11)$ dB; EN ISO 140-3

f (Hz)	100	125	160	200	250	315	400	500	630	800	1000	1250	1600	2000	2500	3150	4000	5000
R (dB)	17.5	25.3	36.2	39.7	39.3	39.9	45.4	47.0	48.0	49.7	51.2	49.7	49.1	47.5	49.1	56.7	58.8	58.5

Figure 3.24 - Wall 1+1 with simple structure

2+1 wall with simple structure

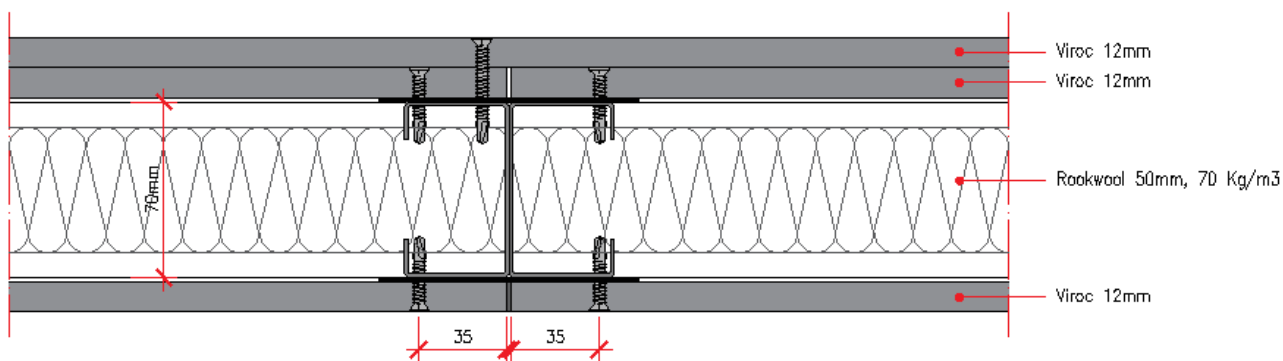

Rw(C;Ctr) = 47(-1;-1) dB; EN ISO 140-3

f (Hz)	50	63	80	100	125	160	200	250	315	400	500	630	800	1000	1250	1600	2000	2500	3150	4000	5000
R (dB)	27.5	18.9	25.5	31.1	39.8	43.0	44.2	44.9	48.6	49.2	49.9	51.3	50.8	49.0	45.3	45.7	45.6	44.9	47.5	48.1	50.8

Figure 3.25 - 2+1 wall with simple structure

2+2 wall with simple structure

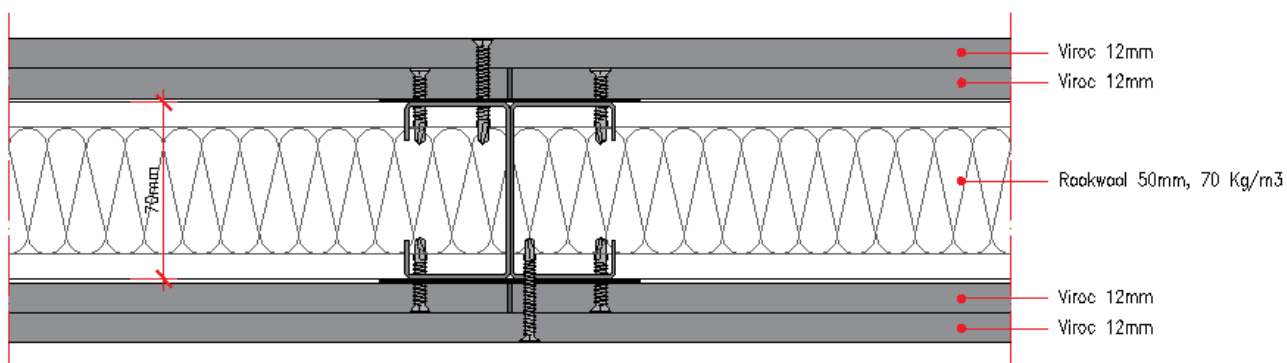

Rw(C;Ctr) = 55(-1;-5) dB; EN ISO 140-3

f (Hz)	50	63	80	100	125	160	200	250	315	400	500	630	800	1000	1250	1600	2000	2500	3150	4000	5000
R (dB)	27.5	20.6	24.0	34.6	42.5	44.5	46.8	48.1	50.6	51.8	51.1	53.0	54.4	55.2	55.8	56.6	56.2	54.1	57.0	56.4	56.2

Figure 3.26 - Wall 2+2 with simple structure

2+1 wall with double structure

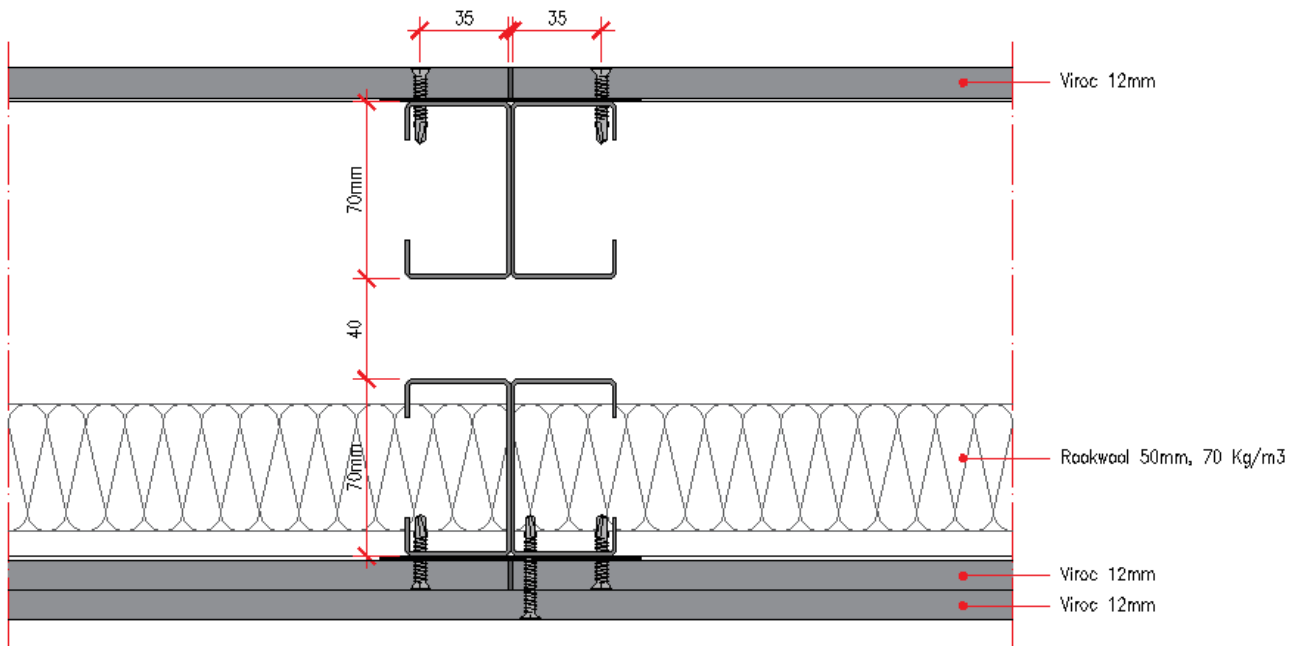

$R_w(C;Ctr) = 59(-3;-11)$ dB; EN ISO 140-3

f (Hz)	50	63	80	100	125	160	200	250	315	400	500	630	800	1000	1250	1600	2000	2500	3150	4000	5000
R (dB)	28.2	22.9	33.1	29.1	40.7	43.7	46.4	50.7	53.3	56.8	57.3	60.3	63.4	66.5	68.8	69.2	67.2	62.4	64.2	65.4	65.2

Figure 3.27 - Wall 2+1 with double structure

2+2 wall with double structure

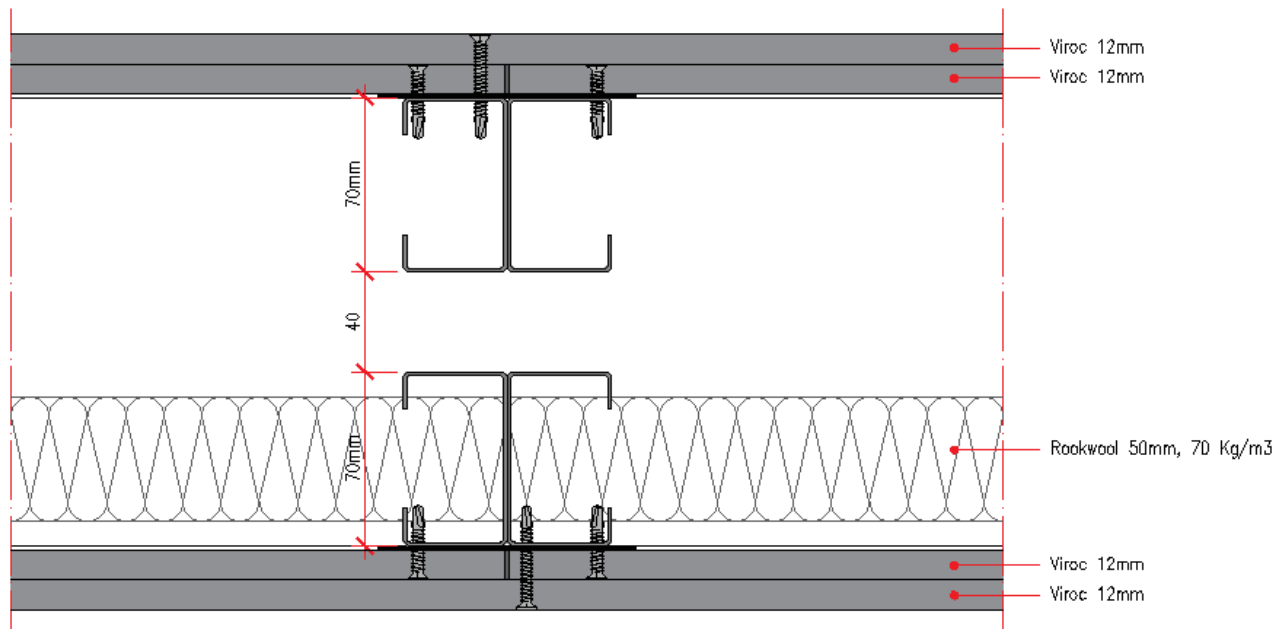

$R_w(C;Ctr) = 62(-2;-7)$ dB; EN ISO 140-3

f (Hz)	50	63	80	100	125	160	200	250	315	400	500	630	800	1000	1250	1600	2000	2500	3150	4000	5000
R (dB)	26.6	27.6	33.4	36.9	45.1	47.5	50.8	52.9	55.9	58.6	57.6	60.4	63.9	66.7	70.7	71.7	71.9	68.6	70.4	71.2	68.7

Figure 3.28 - Wall 2+2 with double structure

3+1 wall with double structure

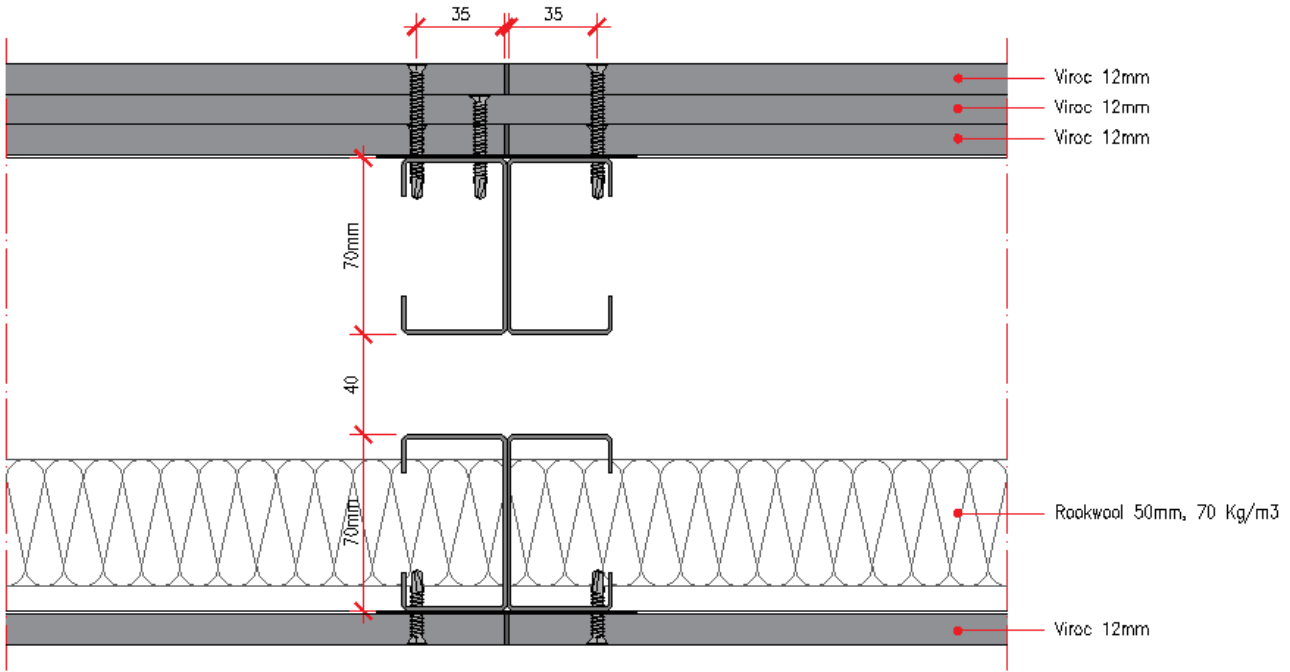

Rw(C;Ctr) = 61(-4;-11) dB; EN ISO 140-3

f (Hz)	50	63	80	100	125	160	200	250	315	400	500	630	800	1000	1250	1600	2000	2500	3150	4000	5000
R (dB)	29.2	26.9	34.9	31.6	41.3	46.0	49.6	52.0	54.3	56.9	57.4	60.5	63.6	66.8	70.3	70.9	70.1	65.1	66.9	67.2	65.5

Figure 3.29 - 3+1 wall with double structure

3+2 wall with double structure

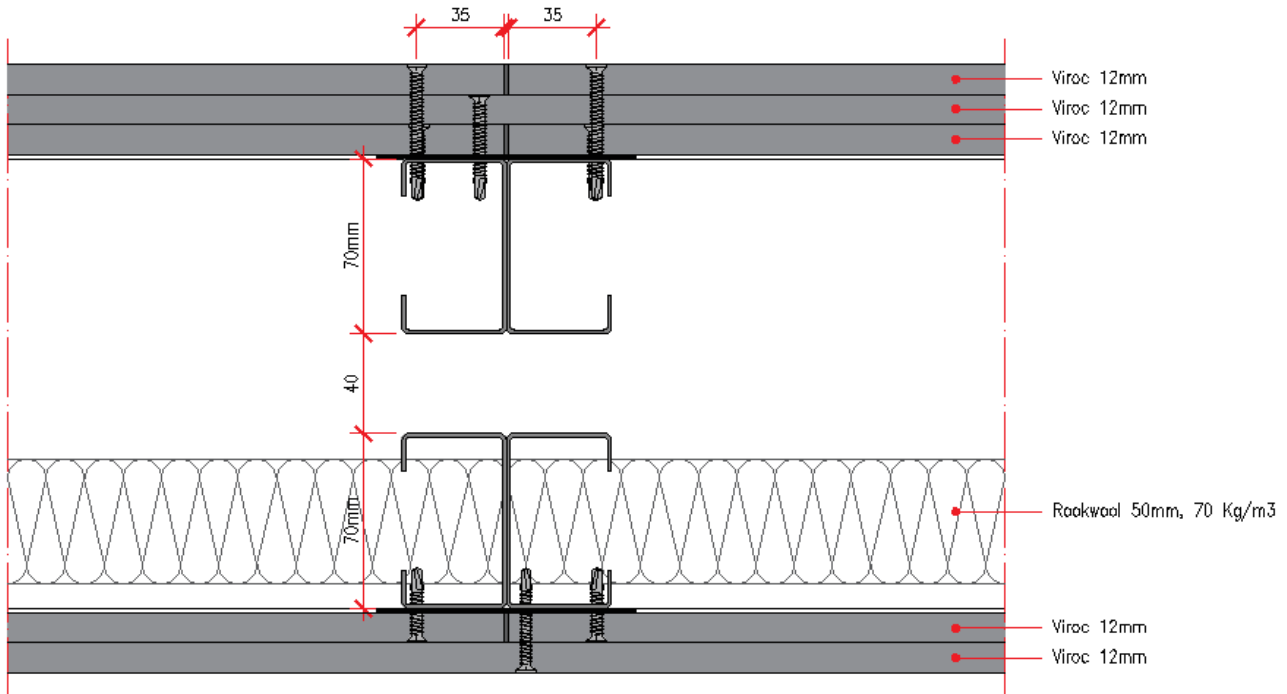

Rw(C;Ctr) = 64(-2;-7) dB; EN ISO 140-3

f (Hz)	50	63	80	100	125	160	200	250	315	400	500	630	800	1000	1250	1600	2000	2500	3150	4000	5000
R (dB)	36.0	34.8	40.9	40.6	46.9	50.4	52.9	53.7	55.9	59.3	58.4	61.1	64.1	67.2	71.8	73.0	73.9	70.8	72.2	71.9	69.4

Figure 3.30 - Wall 3+2 with double structure

3+1+2 wall with double structure

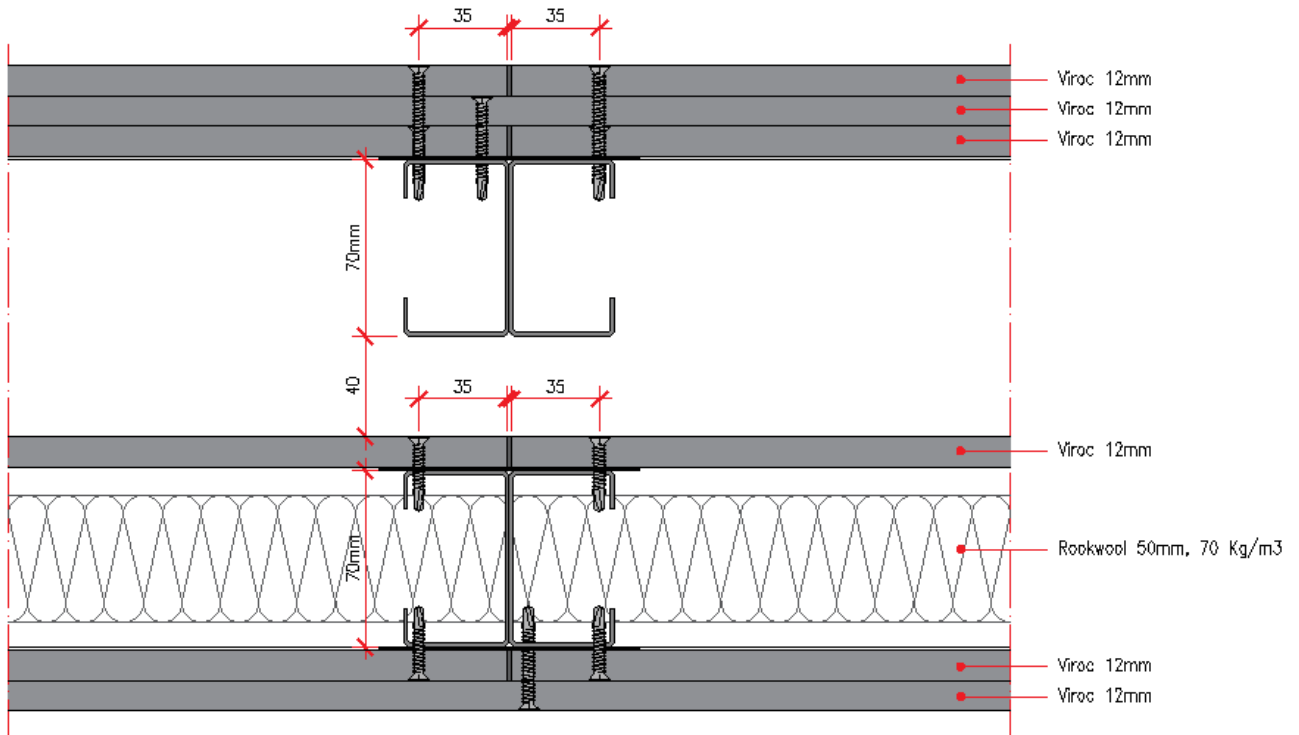

$R_w(C;Ctr) = 65(-2;-7) \text{ dB}; \text{ EN ISO 140-3}$

f (Hz)	50	63	80	100	125	160	200	250	315	400	500	630	800	1000	1250	1600	2000	2500	3150	4000	5000
R (dB)	32.8	28.8	32.6	41.7	46.5	51.0	54.6	55.4	57.6	59.5	58.4	61.8	64.8	67.2	71.8	73.0	73.3	73.5	73.6	71.3	68.2

Figure 3.31 - 3+1+2 wall with double structure

3.8 Fire resistance

Viroc Portugal has two fire-resistant wall solutions that have been experimentally tested.

Both solutions were characterised according to European standard EN 13501-2.

Figures 3.32 to 3.35 show the wall configurations tested and the results obtained.

Wall	Fire resistance	Representation
150 mm	EI90	Figures 3.32 and 3.33
200 mm	EI120	Figures 3.34 and 3.35

90 minute fire resistant wall (EI90)

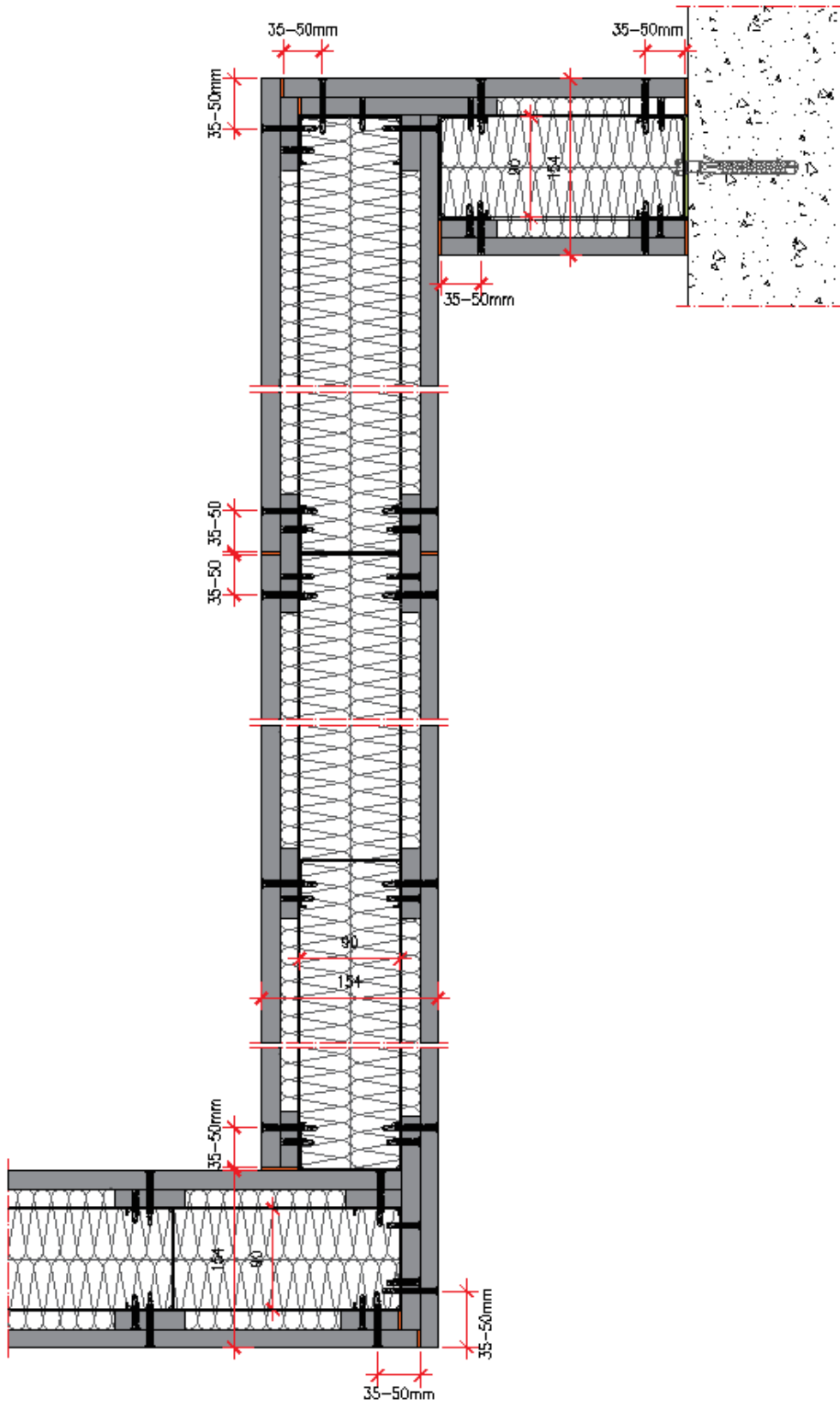

Figure 3.32 - EI90 Wall, Horizontal Section

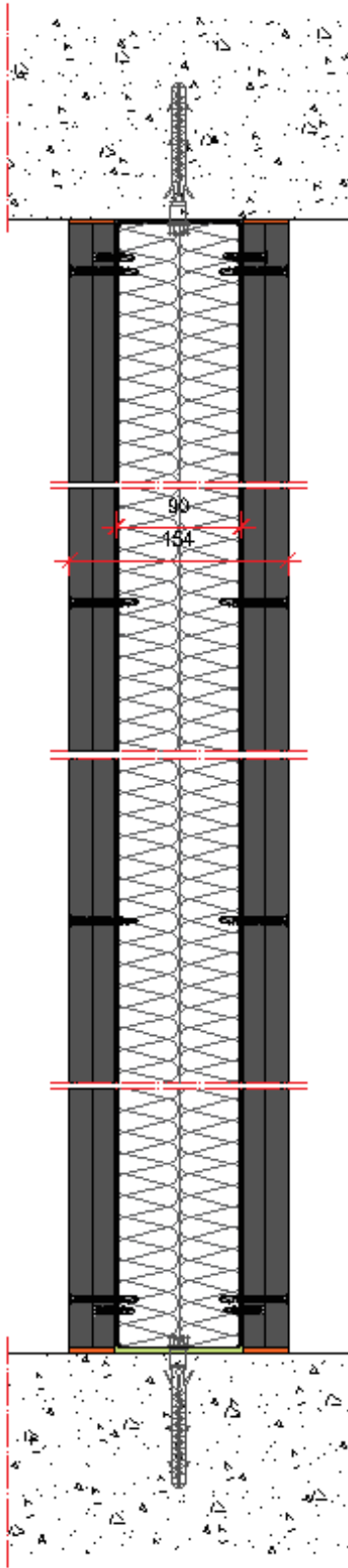

Figure 3.33 - EI90 Wall, Vertical Section

120 minute fire resistant wall (EI120)

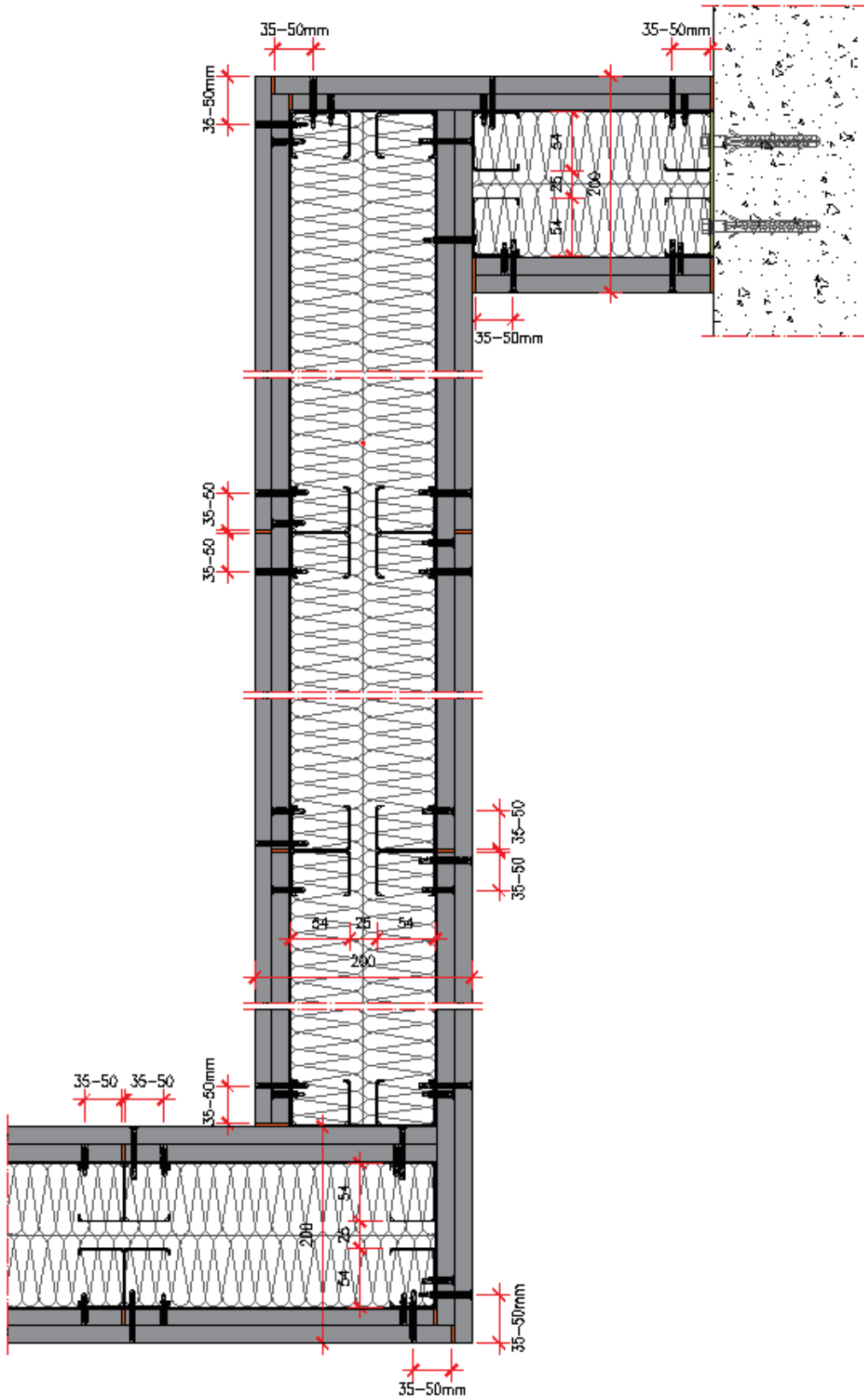

Figure 3.34 - EI120 Wall, Horizontal Section

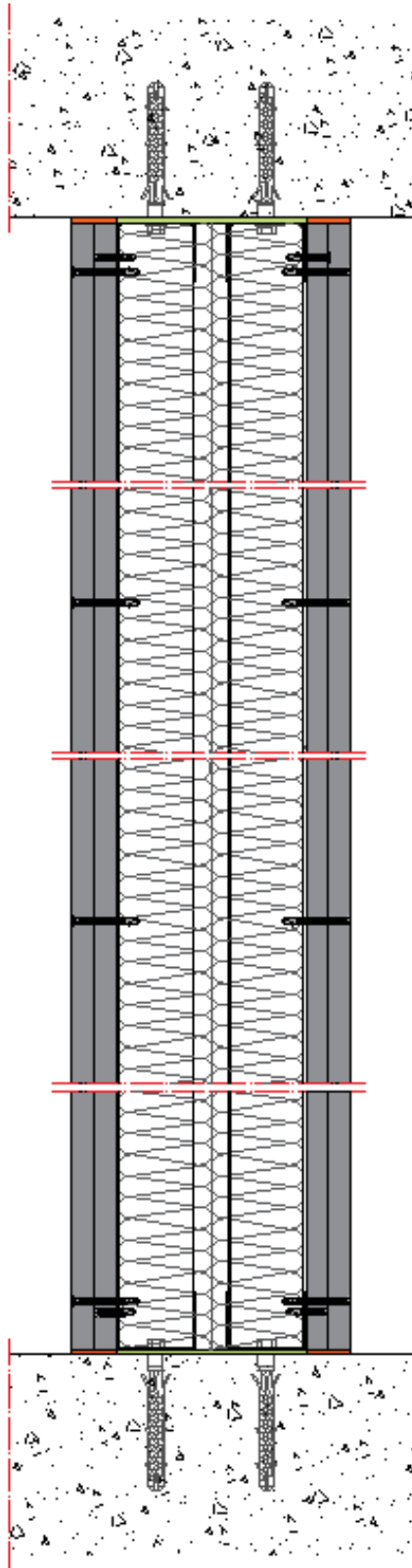

Figure 3.35 - EI120 Wall, Vertical Section

3.9 Special finishes

Partition walls and wall cladding made with Viroc panels can be barred, giving them a continuous appearance, covered with ceramic tiles or with an ETIC.

The materials used to create these types of finishes must be suitable for the dimensional variations that the panel has and must be very elastic.

There are solutions developed by SIKA, BOSTIK, MAPEI, KERAKOLL, SEIGNEURIE, GARNOTEC, which are suitable for application over the Viroc panel.



Technical File

Chapter 4 - Floors

Cement-bonded particleboards
Agglomerated particle board with cement

Office

Av. Infante Dom Henrique 337, 3rd Floor
1800- 210 LISBON, PORTUGAL

Factory

VIROC Portugal S.A.
National Road 10
Km 44.7, Vale da Rosa
2914-519 SETÚBAL, PORTUGAL

In/ investwood

www.investwood.pt

CONTENTS

4. FLOORS	5
4.1 General features	5
4.2 Beam-supported panel	6
4.2.1 Thicknesses	6
4.2.2 Panel thickness tolerances	6
4.2.3 Fasteners	6
4.2.4 Panel layout	6
4.2.5 Screws	7
4.2.6 Adhesive mastic	8
4.2.7 Nails	9
4.2.8 Support structure	10
4.2.9 Special finishes	10
4.2.10 Safety check	11
4.2.11 Example of safety check, uniformly distributed loads	12
4.2.12 Example of safety check, concentrated overload (knife load)	13
4.3 Panel resting on continuous support	14
4.3.1 Thickness	14
4.3.2 Thickness tolerances	14
4.3.3 Support structure	14
4.3.4 Fasteners	14
4.4 Surface treatment	15
4.5 Varnish or paint to be used	15
4.6 Joints between panels	16
4.7 Panel edges	16

INDEX TO TABLES AND FIGURES

Figure 4.1 - Viroc floor supported on beams	6
Figure 4.2 - Arrangement of panels, supported on beams	7
Figure 4.3 - Location of the fixings	7
Figure 4.4 - Galvanised steel screw for wooden structure	8
Figure 4.5 - Galvanised steel screws for metal structure	8
Figure 4.6 - Longitudinal section	8
Figure 4.7 - Detail of joint	8
Figure 4.8 - Panel bonding system with mastic	9
Figure 4.9 - Headless nail	9
Figure 4.10 - Pneumatic nail gun	9
Figure 4.11 - Location of the nails	10
Figure 4.12 - Joint between panels	10
Figure 4.13 - Viroc flooring sustained on continuous support	14
Figure 4.14 - Notched trowel for spreading polyurethane mortar	15
Figure 4.15 - Longitudinal section, Viroc layed with polyurethane mortar	15
Figure 4.16 - Joints between panels, filled with mastic	16
Figure 4.17 - Joints between bevelled machined panels	16
TABLE OF UNIFORMLY DISTRIBUTED LOADS	17
Table 1 - Floor load table	17

Credits

Author

Mr José Pinheiro Soares,
suporte.tecnico@investwood.pt

Review

CS Traduções
geral@cstraducoes.pt

Viroc Portugal S.A. reserves the right to modify this document without prior notice.

This Technical File annuls all previous technical documents.

Issue: 15 February 2024

4. FLOORS

Due to their strength, Viroc panels can be used as a support and finishing element for floors, supported on beams or as a covering material for a new or existing floor.

When supported on beams (wooden or metal), the maximum distance between them must not exceed 600 mm.

The support of a roof supported on beams with Viroc panels must meet the same requirements as a floor.

It is the installer's responsibility to check the security conditions of the support structure, in particular the distance between the supports and the width of the supports for correct installation of the panels.

Viroc panels undergo small dimensional variations with changes in relative humidity and temperature surrounding. The Viroc panel can be expected to accommodate a maximum dimensional variation of -0.1% (shrinkage) to +0.05% (expansion) in an interior application.

4.1 General features

Application

Interior

Maximum panel size

3000x1250 mm

Any intermediate dimensions obtained by cutting the standard dimension panel are possible.

Cutting tolerances

Length and width: ± 3 mm

Squaring: ≤ 2 mm/m

Edge straightness: ≤ 1.5 mm/m

4.2 Beam-supported panel

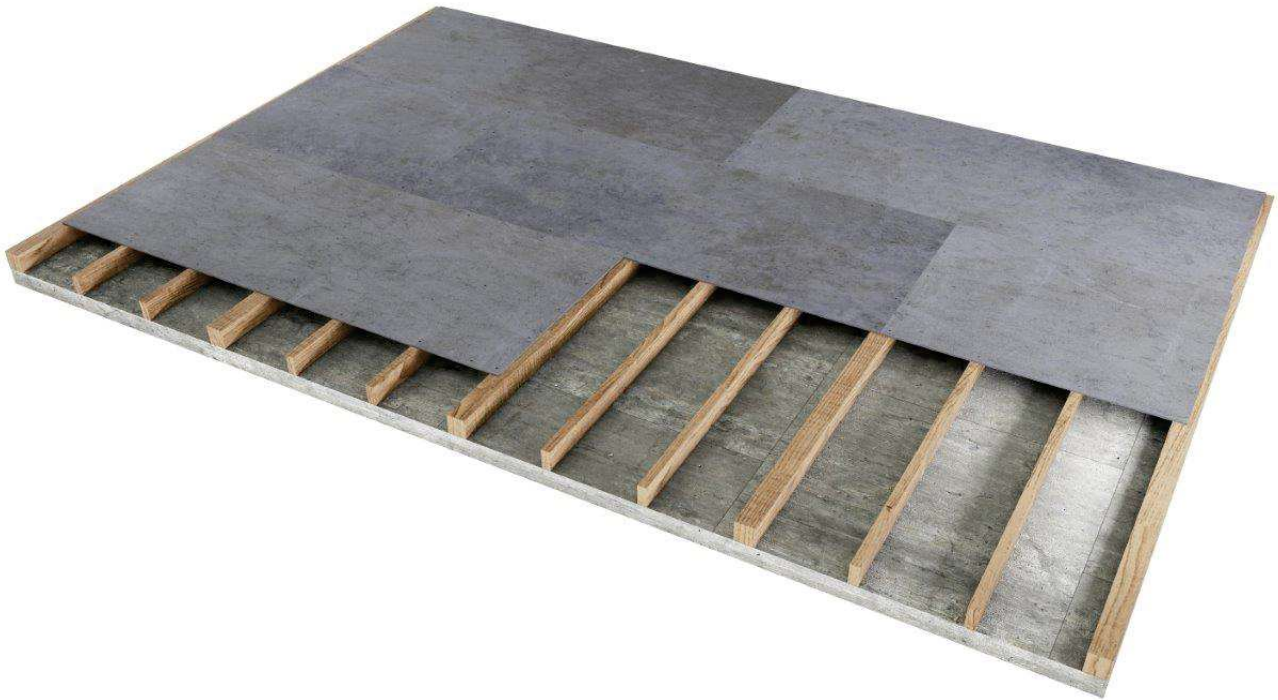

Figure 4.1 - Viroc floor supported on beams

4.2.1 Thicknesses

19, 22, 25, 28 and 32 mm

4.2.2 Panel thickness tolerances

± 1.5 mm

4.2.3 Fasteners

Depending on the type of structure, the panels can be fixed with screws, nails, and rivets or glued with polyurethane adhesives (PU mastic).

4.2.4 Panel layout

The panels must be arranged so that the joints are misaligned, as shown in figure 4.2.

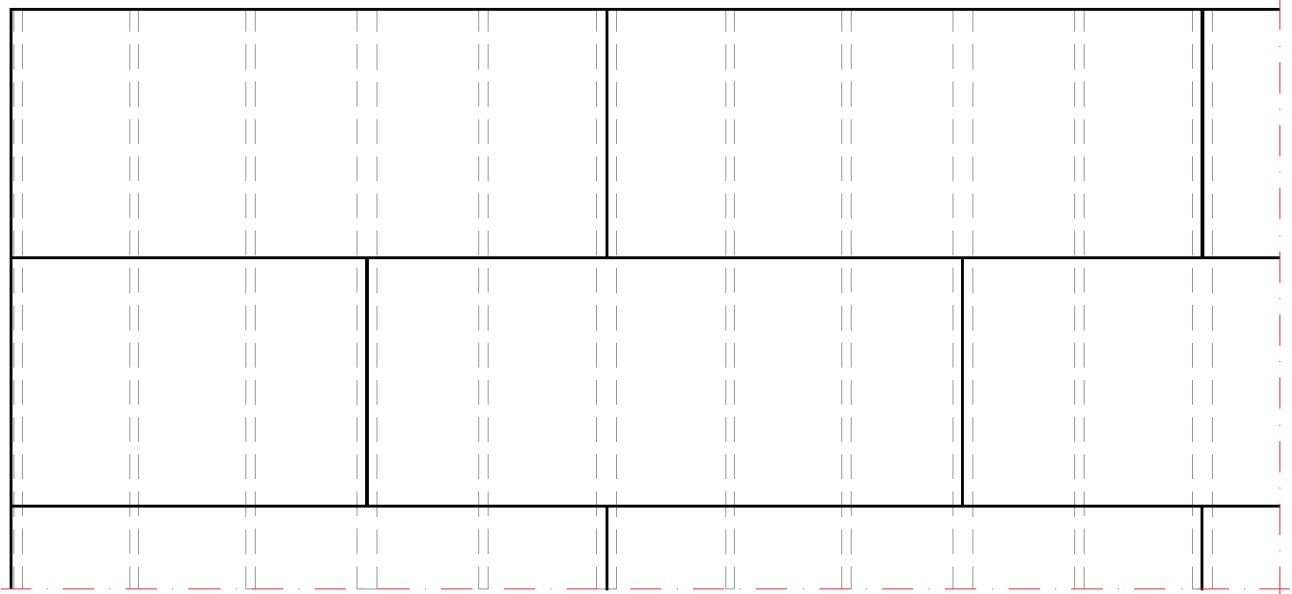

Figure 4.2 - Arrangement of panels, supported on beams

4.2.5 Screws

When fixing the panels with screws, the distances must be taken into account as shown in figure 4.3.

A screw placed too close to the edges can cause the panel to break.

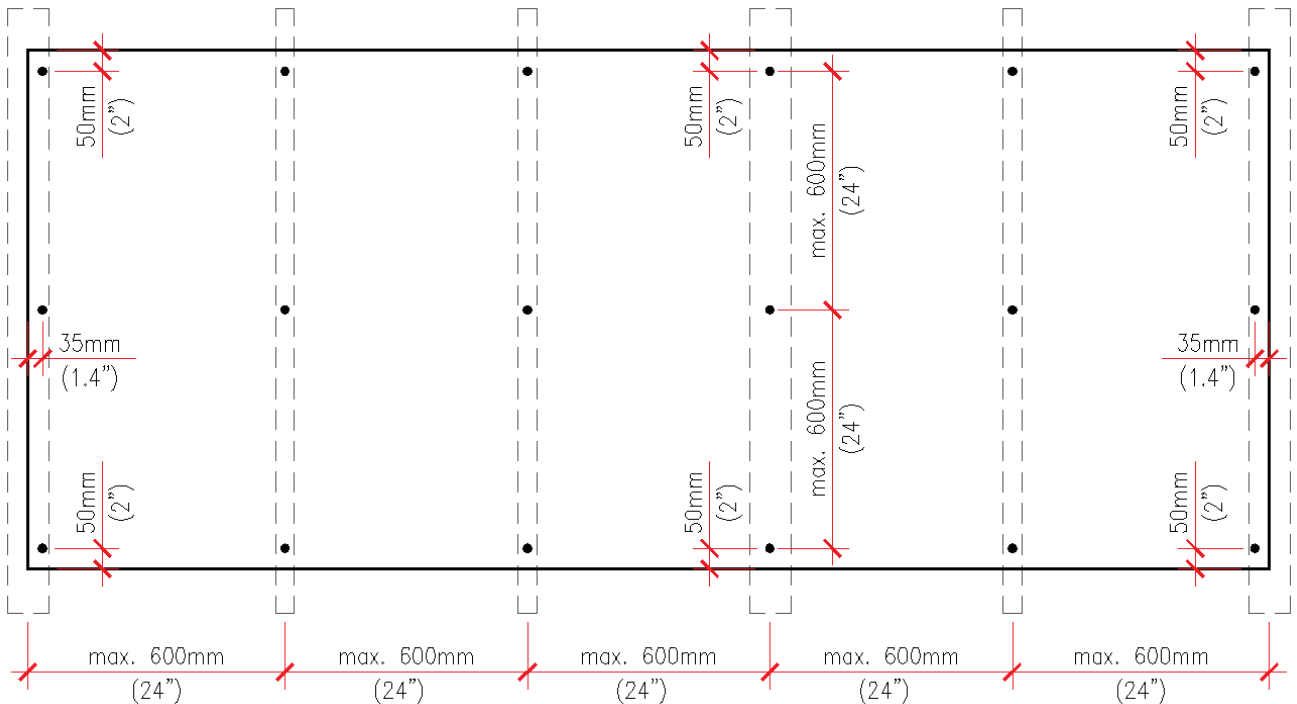

Figure 4.3 - Location of the fixings

Screws for wooden structures must have an anchoring length (depth driven into the wood) of at least 30 mm (see figure 4.4).

When the support structure is made of metal, in addition to the appropriate length of the screw body, the drill tip must be of an appropriate size to pierce the thickness of the metal it will be fixed to (see figure 4.5).

The maximum distance between screws must not exceed 600 mm.

SFS Intec and ETANCO have suitable screws. Screws from other manufacturers can be used as long as they have the same performance.



Figure 4.4 - Galvanised steel screw for wooden structure



Figure 4.5 - Galvanised steel screws for metal structure

4.2.6 Adhesive mastic

Mastic bonding systems can be used to bond Viroc panels to wooden and metal structures.

This type of fixing consists of:

- Adhesion primer for the support structure;
- Adhesion primer for the Viroc panel;
- Double-sided adhesive tape;
- Mastic adhesive.

The adhesive tape is 3 mm thick and its function is to fix the panels while the mastic adhesive is fresh, i.e. without resistance. This ensures that the strand is 3 mm thick without being crushed (see figures 4.6 and 4.7).

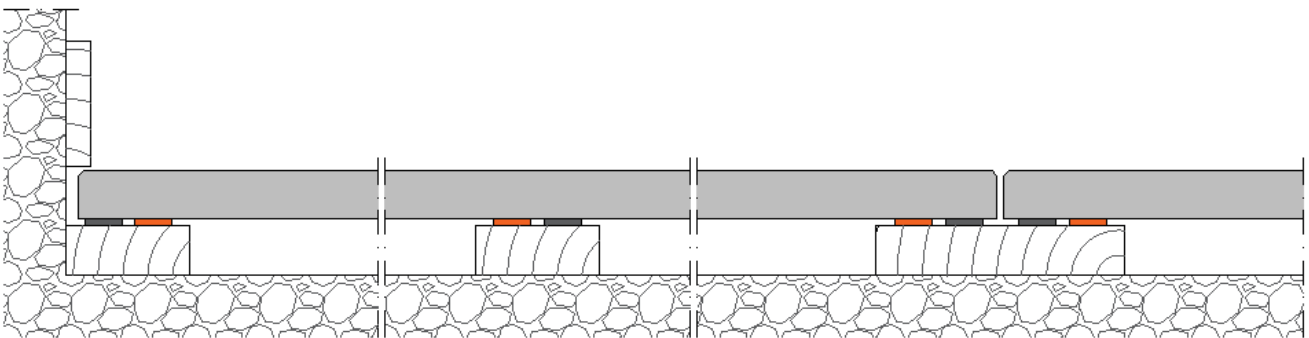

Figure 4.6 - Longitudinal section

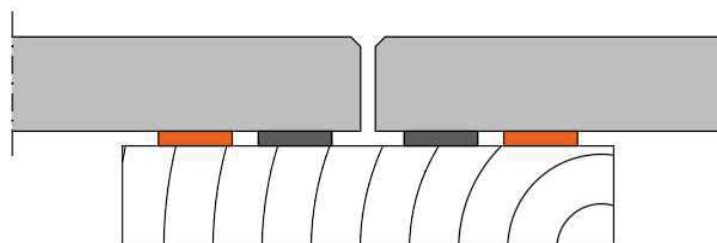

Figure 4.7 - Detail of joint

- Double-sided adhesive tape
- Mastic Adhesive

Sika and Bostik have systems suitable for this application. The manufacturers of these materials should always be consulted for advice and correct application (see figure 4.8).



Figure 4.8 - Panel bonding system with mastic

4.2.7 Nails

If the structure is made of wood, galvanised steel or stainless steel nails can be used to fix the panels to the structure.

There are headless nails that are practically invisible (see figure 4.9).

The nails should be applied using a suitable pneumatic gun (see figure 4.10). Before the final fixing of the panels begins, a series of tests must be carried out to set the right pressure and force for the nails to be driven in correctly.

When fixing with nails, the distances between fixings must not exceed 600 mm in the horizontal direction and 400 mm in the vertical direction (see figure 4.11).



Figure 4.9 - Headless nail



Figure 4.10 - Pneumatic nail gun

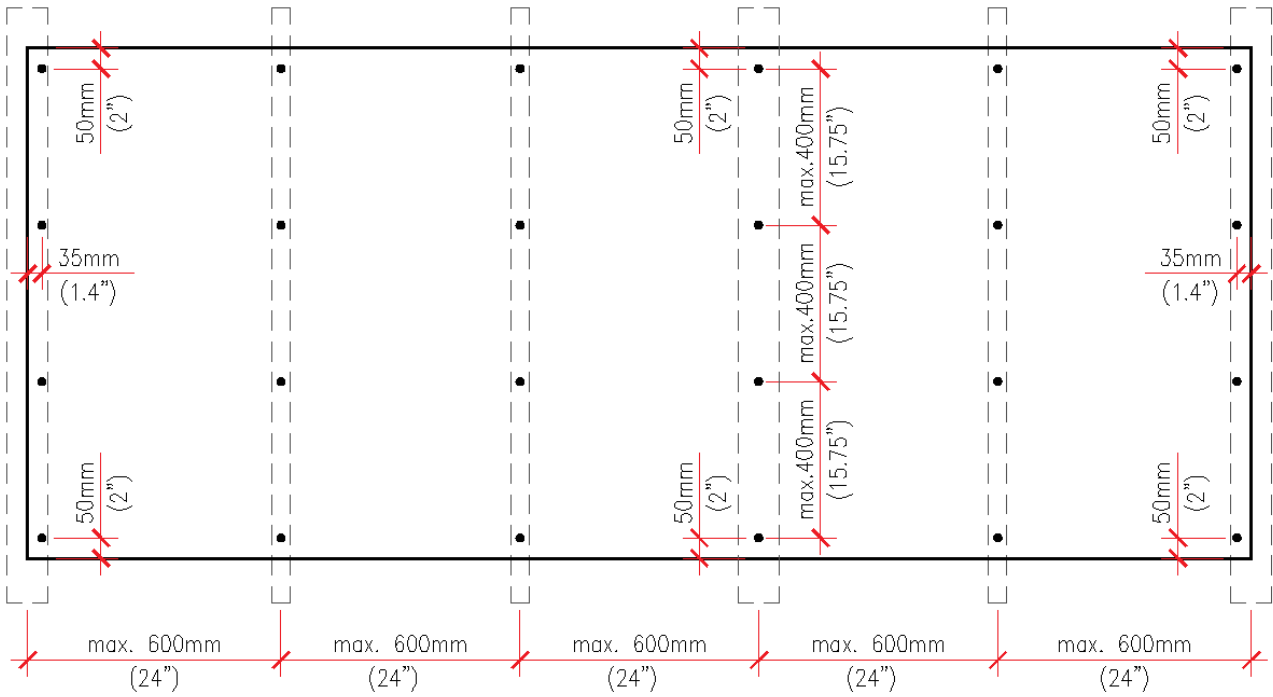

Figure 4.11 - Location of the nails

4.2.8 Support structure

Viroc panels can be supported on a wooden or metal frame. The panels must be positioned so that their longitudinal length is perpendicular to the orientation of the support structure. The structure that will support the Viroc panels must be aligned and properly levelled.

The support structure must be wide enough to allow the fixings to be positioned correctly, respecting the minimum distances between the screws and the edge of the panels, and have the capacity to absorb small positioning errors (see figure 4.12).

The maximum distance between the axes of the support elements (spans) must be 600 mm. Their alignment between adjacent elements must be checked and should not differ by more than 5 mm.

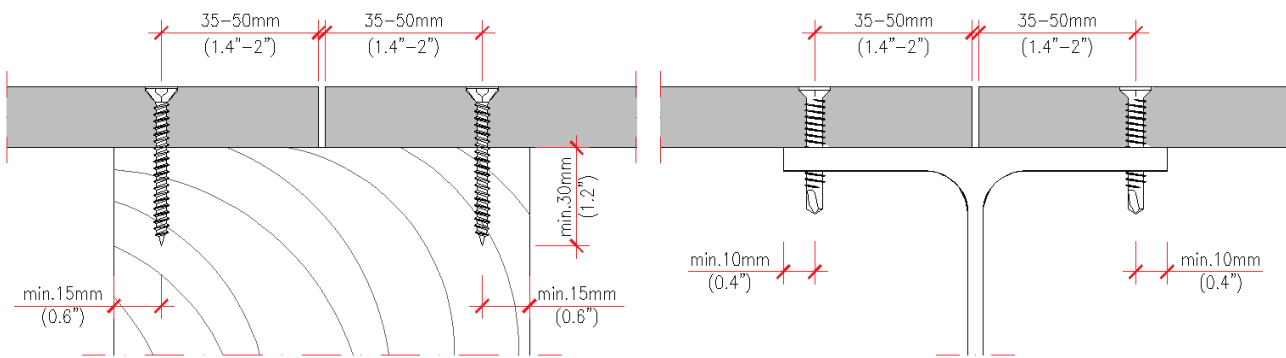

Figure 4.12 - Joint between panels

4.2.9 Special finishes

Floors made with Viroc panels can be finished with wood coverings such as Lamparquet, parquet and parquet flooring or a ceramic finish.

The materials used to glue these types of finishes have to be suitable for the dimensional variations that the panel has, and they need to be very elastic. Polyurethane adhesives have been widely used because of their good adhesion to the Viroc panel and their great elasticity.

The manufacturers of these adhesives should always be consulted for advice and correct application.

4.2.10 Safety check

The safety check of a Viroc panel is carried out in accordance with the requirements of the Eurocode 1 and 5, taking into account the National Application Documents (RSA).

The following values must be adopted when verifying Security to Ultimate Strength Limit States:

- Specific weight (γ), 13.5 kN/m³;
- Density (ρ), 1350 Kg/m³;
- Characteristic flexural tensile strength ($f_{m,k}$), 9.0 MPa;
- Characteristic shear stress ($f_{v,k}$), 1.0 MPa;
- Partial Coefficient of Security (γ_M), 1.3
- Modification factor (k_{mod})
 - Permanent actions, $k_{mod} = 0.30$
 - Long-term actions, $k_{mod} = 0.45$
 - Medium-term actions, $k_{mod} = 0.65$
 - Short-term actions, $k_{mod} = 0.85$

$$M_{Rd} = k_{mod} \cdot W \cdot f_{m,k} / \gamma_M ; V_{Rd} = k_{mod} \cdot A_v \cdot f_{v,k} / \gamma_M$$

The following values must be adopted when checking Safety at Deformation Limit States:

- Modulus of Elasticity (E_m), 4500 MPa;
- Deformation factor (k_{def}), 2.25
- Long term deformation, $\delta_{\infty} = \delta_{instant} \times (1+k_{def})$

The deformation of the panels must not jeopardise the normal functioning of the floors. The maximum deformation due to permanent loads and overloads must not exceed the limit of $L/250$ of the span between the support fixings.

Examples of the safety check can be found in chapters 4.2.11 and 4.2.12.

Table 1 shows a Load Table for a quick safety check on floors.

4.2.11 Example of safety check, uniformly distributed loads

Dimensioning a floor for a house made of 25 mm thick Viroc panels 2.40 m long, with supports every 60 cm.

Actions

Permanent loads	
Self-weight (Pp)	0.34 kN/m ²
Remaining permanent loads (RCp)	2.00 kN/m ²
Overloads	
Housing (Sc)	2.00 kN/m ²
Concentrated load (knife load)	1.50 kN/m

Uniformly Distributed Loads

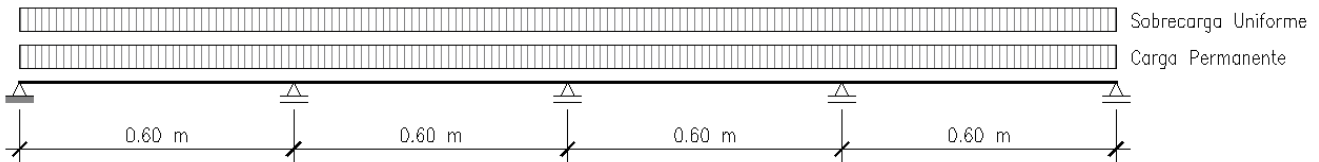

Ultimate Limit State Safety Check

Combination of actions with overload as basic variable action

$$S_{sd} = 1.35 Pp + 1.50 RCp + 1.50 Sc$$

$$k_{mod} = 0.65 \text{ Medium-term actions}$$

Maximum Efforts

$$M_{Sd,max} = 0.24 \text{ kNm/m}$$

$$M_{Rd} = k_{mod} \cdot w \cdot f_{m,k} / \gamma_M = 0.65 \times (25/1000)^2 / 6 \times 9000 / 1.3 = 0.47 \text{ kN/m} > 0.24 \text{ kNm/m}$$

$$V_{sd,max} = 2.35 \text{ kN/m}$$

$$V_{Rd} = k_{mod} \cdot A_v \cdot f_{v,k} / \gamma_M = 0.65 \times 5 / 6 \times (25/1000) \times 1000 / 1.3 = 10.4 \text{ kN/m} > 2.35 \text{ kN/m}$$

Safety check at Deformation Limit States

Quasi-permanent combination of actions

Long-term deformation

$$\delta_{\infty} = \delta_{inst} \times (1 + k_{Def})$$

$$\delta_{inst} = 1.0 \delta_{Pp} + 1.0 \delta_{RCp} + \psi_2 \delta_{Sc}; (\psi_2 = 0.2)$$

Maximum deformation L/250, 600/250 = 2.4 mm

Maximum instantaneous deformation $\delta_{inst} = 0.4 \text{ mm}$

Long-term deformation, $\delta_{fin} = \delta_{inst} \times (1 + 2.25) = 1.3 \text{ mm} < 2.4 \text{ mm}$

4.2.12 Example of safety check, concentrated overload (knife load)

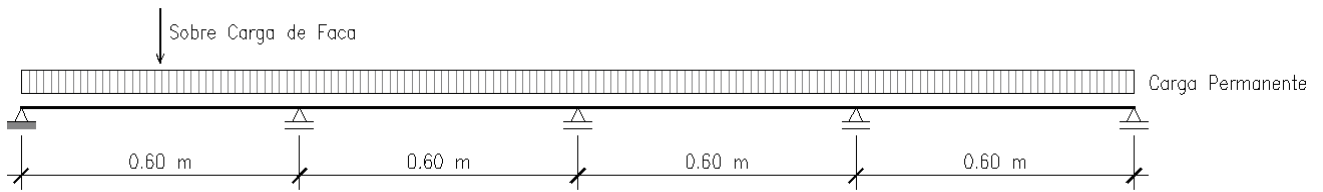

Ultimate Limit State Safety Check

Combination of actions with overload as basic variable action

$$S_{sd} = 1.35 P_p + 1.5 R_{Cp} + 1.5 S_c$$

$$k_{mod} = 0.85 \text{ - Short-term actions}$$

Maximum Efforts

$$M_{Sd,max} = 0.37 \text{ kNm/m}$$

$$M_{Rd} = k_{mod} \cdot w \cdot f_{m,k} / \gamma_M = 0.85 \times (25/1000)^2 / 6 \cdot 9000 / 1.3 = 0.61 \text{ kNm/m} > 0.37 \text{ kNm/m}$$

$$V_{sd,max} = 2.36 \text{ kN/m}$$

$$V_{Rd} = k_{mod} \cdot A_v \cdot f_{v,k} / \gamma_M = 0.85 \times 5 / 6 \times (25/1000) \times 1000 / 1.3 = 13.62 \text{ kN/m} > 2.36 \text{ kN/m}$$

Safety check at Deformation Limit States

Characteristic combination of actions

Instantaneous deformation

$$\delta_{inst} = 1.0 \delta_{Pp} + 1.0 \delta_{RCp} + \psi_0 \delta_{Sc} ; (\psi_0 = 0.4)$$

$$\text{Maximum deformation } L/250, 600/250 = 2.4 \text{ mm}$$

$$\text{Maximum instantaneous deformation } \delta_{inst} = 0.7 \text{ mm} < 2.4 \text{ mm}$$

Note: A concentrated point overload requires software to calculate the stresses, but the entire safety checking process is similar.

4.3 Panel resting on continuous support



Figure 4.13 - Viroc flooring sustained on continuous support

4.3.1 Thickness

12 mm

4.3.2 Thickness tolerances

± 1 mm

4.3.3 Support structure

Viroc panels can be sustained on a new or existing continuous support. In both situations, the substrate must be levelled and in good condition to support the new coating. Surfaces must be clean of dirt and grease to ensure good adhesion.

4.3.4 Fasteners

The panels are fixed to the substrate with an elastic polyurethane mortar, spread over the entire surface continuously with a notched trowel (see figures 4.13, 4.14 and 4.15).

Sika, Bostik and Mapei have mortars suitable for this application. Mortars from other manufacturers can be used as long as they ensure the right performance.

The manufacturers of these materials should always be consulted for advice and correct application.



Figure 4.14 - Notched trowel for spreading polyurethane mortar

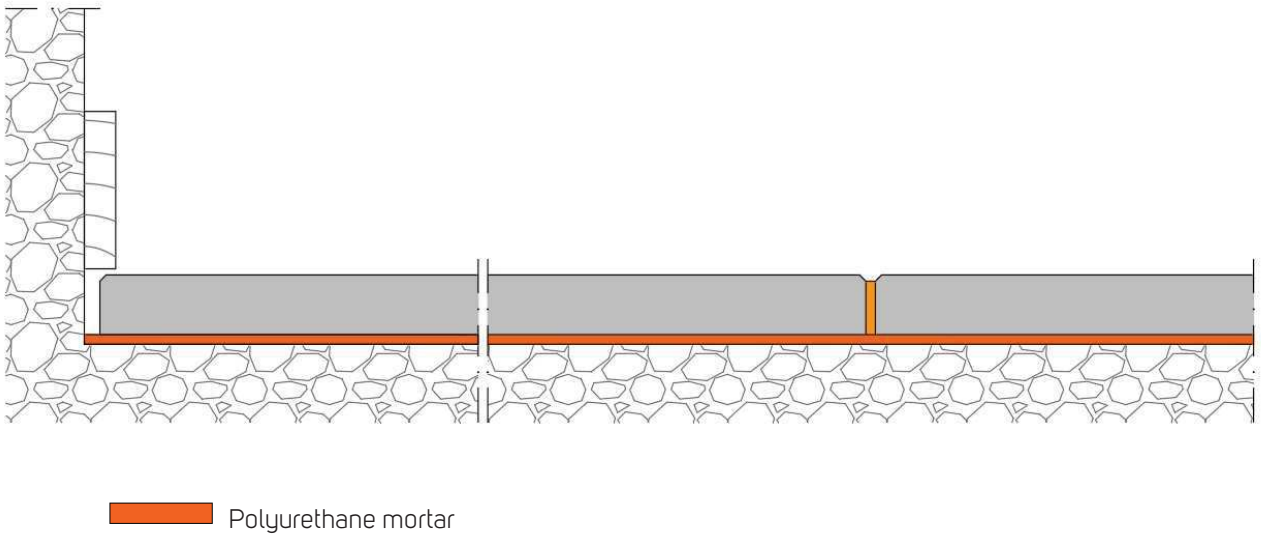

Figure 4.15 - Longitudinal section, Viroc layed with polyurethane mortar

4.4 Surface treatment

The panels must be protected with scratch-resistant paint or varnish suitable for flooring.

Before applying the varnish to the panels, the surface must be completely clean and dry, with no grease, dust or salts. Cleaning can be done by polishing with cleaning disks. VIROC Portugal has suitable disks, which it can supply on request. Alternatively, the surfaces can be cleaned using sandpaper with a fine-grained disk equal to or greater than 120.

4.5 Varnish or paint to be used

The purpose of applying varnish to the Viroc panel is to protect it from the aggressions of use, increasing its durability, making it easier to clean and maintaining its appearance over time.

The application of a varnish can alter the natural colour tone of the Viroc panel, giving it a "wet" appearance with some shine. There are no specific paints or varnishes to be applied to Viroc. The panel has a surface alkalinity (PH) of 11 to 13, so paints and varnishes suitable for concrete and wood surfaces at the same time are usually the best when applied to Viroc panel.

Paints and varnishes made from acrylic resins or solvent-based aliphatic polyurethanes are the ones that have shown the best performance. Water-based acrylic resin or aliphatic polyurethane varnishes have the least effect on the panel original

colour. In addition to the above, paints and varnishes must be suitable for their intended purpose and have the hardness and resistance required for use on floors.

Generally speaking, varnishes are easy to apply, but it is very important to bear in mind that the application must be continuous and constant, to guarantee the homogeneity of the finish on the panel and so that the surface doesn't become stained and have different shades. Panels must always be painted/varnished on both sides and tops, except in the conditions described in 4.3 where the adhesive to the substrate must be applied directly to the panel. The application procedures for paints and varnishes must always be followed applying the coats recommended by the manufacturers.

4.6 Joints between panels

The joints between panels should have a gap of 2 to 3 mm and can be filled with a bead of silicone or mastic (see figure 4.16).

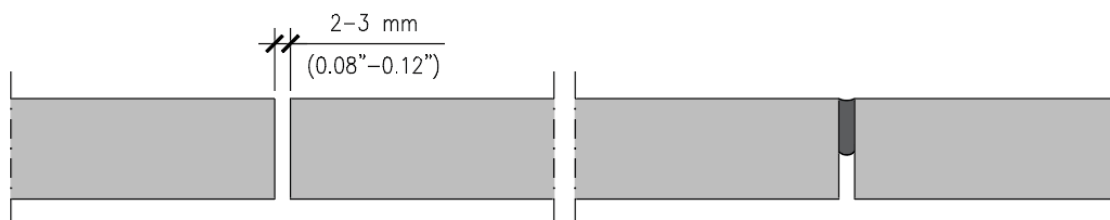

Figure 4.16 - Joints between panels, filled with mastic

4.7 Panel edges

The edges of the panels must be machined in a bevel shape of 2 to 3 mm (see figure 4.17); otherwise the differences in thickness due to the manufacturing tolerance will be visible and will break with use.

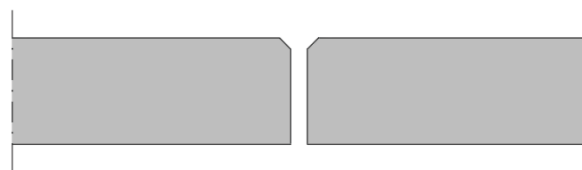

Figure 4.17 - Joints between bevelled machined panels

TABLE OF UNIFORMLY DISTRIBUTED LOADS

Flexural breaking stress: 9 MPa

Modulus of Elasticity: 4500 MPa

Coefficient of Security: 3

2 Supports

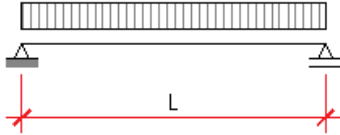

3 Supports

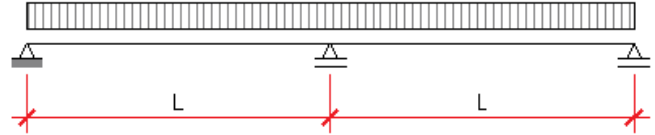

Multiple Supports (>3)

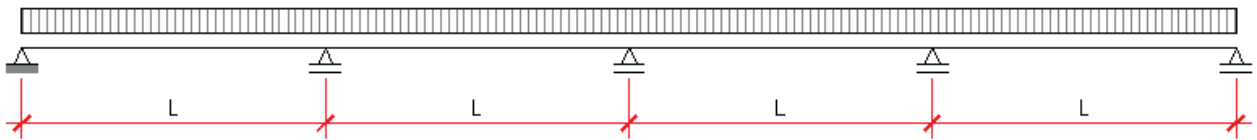

Thickness panel		Span (L)		2 or 3 Supports				Multiple Supports			
mm	polg.	m	polg.	Max. load		L/250		Max. load		L/250	
				kN/m ²	psf	kN/m ²	psf	kN/m ²	psf	kN/m ²	psf
19	3/4	0,3	12	15,8	330	15,8	330	18,5	386	18,5	386
		0,4	16	8,8	183	8,8	183	10,3	215	10,3	215
		0,5	20	5,5	115	5,5	115	6,5	136	6,5	136
		0,6	24	3,8	78	3,4	71	4,4	93	4,4	93
22	7/8	0,3	12	21,2	443	21,2	443	24,8	519	24,8	519
		0,4	16	11,8	247	11,8	247	13,8	289	13,8	289
		0,5	20	7,4	156	7,4	156	8,7	183	8,7	183
		0,6	24	5,1	106	5,1	106	6,0	125	6,0	125
25	1	0,3	12	27,4	573	27,4	573	32,1	671	32,1	671
		0,4	16	15,3	319	15,3	319	17,9	374	17,9	374
		0,5	20	9,7	202	9,7	202	11,3	237	11,3	237
		0,6	24	6,6	138	6,6	138	7,8	162	7,8	162
28	1 1/8	0,3	12	34,5	720	34,5	720	40,3	842	40,3	842
		0,4	16	19,2	401	19,2	401	22,5	470	22,5	470
		0,5	20	12,2	254	12,2	254	14,3	298	14,3	298
		0,6	24	8,3	174	8,3	174	9,8	205	9,8	205
32	1 1/4	0,3	12	45,1	941	45,1	941	52,7	1101	52,7	1101
		0,4	16	25,2	526	25,2	526	29,5	616	29,5	616
		0,5	20	16,0	333	16,0	333	18,7	391	18,7	391
		0,6	24	10,9	229	10,9	229	12,9	269	12,9	269

Table 1 - Floor load table



Technical File

Chapter 5 - Ceilings

Cement-bonded particleboards
Agglomerated particle board with cement

Office

Av. Infante Dom Henrique 337, 3rd Floor
1800- 210 LISBON, PORTUGAL

Factory

VIROC Portugal S.A.
National Road 10
Km 44.7, Vale da Rosa
2914-519 SETÚBAL, PORTUGAL

In/ investwood

www.investwood.pt

INDEX

5. FALSE CEILINGS	5
5.1 General features.....	5
5.2 Fasteners.....	6
5.3 Support structure.....	6
5.3.1 Wooden beams.....	6
5.3.2 Galvanised steel profiles.....	7
5.3.3 Aluminium profiles.....	8
5.3.4 Supporting squares.....	9
5.3.5 Threaded rod + pivots.....	9
5.4 Panel installation.....	10
5.4.1 Outdoors.....	10
5.4.2 Indoors.....	11
5.5 Surface treatment.....	12
5.6 Paints and varnishes.....	12
5.7 Joints between panels.....	12
5.8 Ceiling type sections.....	13
5.9 Acoustic performance.....	15
5.9.1 Ceiling with 100 mm box (Dx=100 mm).....	16
5.9.2 Ceiling with 200 mm box (Dx=200 mm).....	16
5.9.3 Ceiling with 400 mm box (Dx=400 mm).....	16

INDEX TO TABLES AND FIGURES

Figure 5.1 - Screws for fixing Viroc panels to ceilings indoors and outdoors.....	6
Figure 5.2 - Screws for fixing Viroc panels to indoor ceilings.....	6
Figure 5.3 - Wooden beams.....	7
Figure 5.4 - Galvanised steel profiles.....	7
Figure 5.5 - Galvanised steel profiles (Alternative).....	8
Figure 5.6 - T47 profile (minimum thickness: 0.7mm).....	8
Figure 5.7 - Aluminium structure.....	9
Figure 5.8 - Detail of panel attachment to support profile.....	9
Figure 5.9 - Pivot for fixing the support profile to the threaded rod.....	10
Figure 5.10 - Roof panel fixings, applied outdoors.....	10
Figure 5.11 - Torque limiting knobs, to be placed on the riveting head.....	11
Figure 5.12 – Screw-centering spanner.....	11
Figure 5.13 - bolt hole centering spanner.....	11
Figure 5.14 – bolt hole centering tool, SFS Intec.....	11
Figure 5.15 - Ceiling panel fixings, applied indoor.....	12
Figure 5.16 - Roof with wooden structure.....	13
Figure 5.17 - Roof with galvanised steel structure.....	13
Figure 5.18 - Roof with galvanised steel TC structure.....	14
Figure 5.19 - Roof with aluminium structure.....	14
Figure 5.20 - Panel 1250x600 mm, with 12 mm diameter holes 32 mm apart between the axes.....	15
Figure 5.21 - Ceiling section, from the experimental tests carried out to determine the sound absorption index.....	15

Credits

Author

Mr José Pinheiro Soares,
suporte.tecnico@investwood.pt

Review

CS Traduções
geral@cstraducoes.pt

Viroc Portugal S.A. reserves the right to modify this document without prior notice.

This Technical File invalidates all previous technical documents.

Issue: 15 February 2024

5. FALSE CEILINGS

Viroc panels can be used as a cladding element for a false ceiling. The support structure is made of galvanised steel or wood, with equidistant supports, the distance between which must not exceed 600 mm.

It is the installer's responsibility to check the safety conditions of the support structure, in particular the distance between the supports and the size of the supports for correct installation of the panels.

Viroc panels undergo small dimensional variations with changes in relative moisture and temperature. The Viroc panel can be expected to accommodate a maximum dimensional variation of -0.1% (shrinkage) to +0.05% (expansion) in an interior application and -0.3% (shrinkage) to +0.1% (expansion) in an exterior application.

The panel fixings must take this into account.

5.1 General features

Application

Interior and exterior

Thicknesses

10 mm in dry indoor areas;

12 mm in moist outdoors or indoor areas such as bathrooms and kitchens.

Maximum panel size

3000x1250 mm.

Any intermediate dimensions obtained by cutting the standard dimension panel are possible.

Panel thickness tolerances

Thickness: 10 mm \pm 0.7 mm; 12 mm \pm 1.0 mm

Cutting tolerances

Length and width: \pm 3 mm

Squaring: \leq 2 mm/m

Edge straightness: \leq 1.5 mm/m

5.2 Fasteners

The panels are fixed with screws or rivets suitable for wooden or metal structures.

Figures 5.1 and 5.2 show the screws and rivets that can be used to fix Viroc panels to ceilings.



Figure 5.1 - Screws for fixing Viroc panels to ceilings indoors and outdoors.



Figure 5.2 - Screws for fixing Viroc panels to indoor ceilings

The location of the screws and the diameter of the bolt holes in the panels must be as shown in figure 5.10 if the ceiling is to be installed outdoors or 5.15 if the ceiling is to be installed indoors.

5.3 Support structure

The support structure can be made of metal or wooden profiles, connected to the ceiling using rigid elements such as supporting squares or flexible ones using threaded rods.

5.3.1 Wooden beams

The profiles supporting the panels can be made of pine wood. The strength of the wood used to make up the uprights must be at least of class C18 according to EN 338 and durability of class 2, 3 or higher according to EN 335.

When assembled on site, wooden uprights must not have a moisture level of more than 18%, with a difference between consecutive elements of no more than 4%. The relative moisture of the wooden uprights is determined according to the method described in standard EN 13183-2, using a tip moisture metre.

The cross-section of the support profiles is generally rectangular, with a minimum dimension of 40x50 mm (see figure 5.3).

The design of these elements must take into account the deformations caused by the actions (self-weight, overloads, etc.), so that they do not jeopardise the normal functioning of the roof. Deformation due to action must not exceed the limit $L/200$ of the span between support fixings.

The width of the uprights must be such that the fixings can be positioned correctly, with the capacity to absorb small positioning errors; the screws must not be less than 15 mm from the end of the upright.

Other types of sections can be used, as long as they have the same performance and durability.

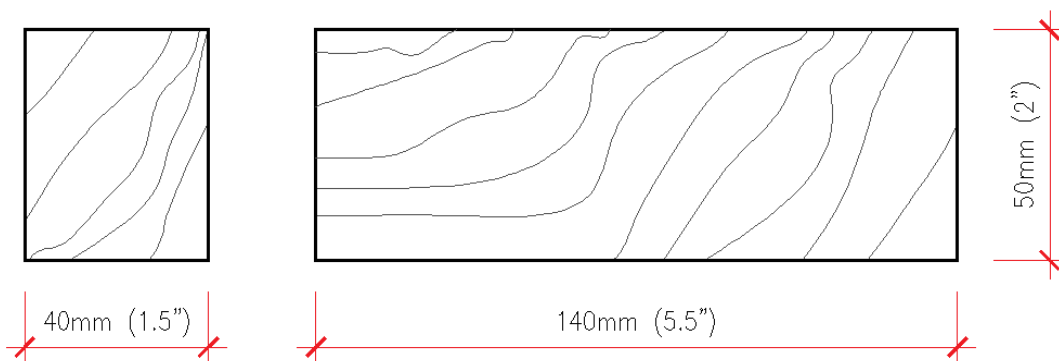

Figure 5.3 - Wooden beams

Minimum resistance of class C18 (EN 338)

5.3.2 Galvanised steel profiles

The galvanised steel profiles are fixed to the load-bearing structure using galvanised or stainless steel supporting squares, with metal anchors or anchors made up of metal screws and plastic bushes.

The minimum strength of the steel used in the upright profiles must be of class DX51D, in accordance with standard EN 10346.

The hot-dip zinc coating (Z) must be 275 g/m² in coastal areas and 140 g/m² in other areas.

The section of the profiles is generally Omega, C or L-shaped with a recommended thickness of 1.5 mm. Other profile shapes can be used; provided they have the same performance and durability (see figures 5.4 and 5.5).

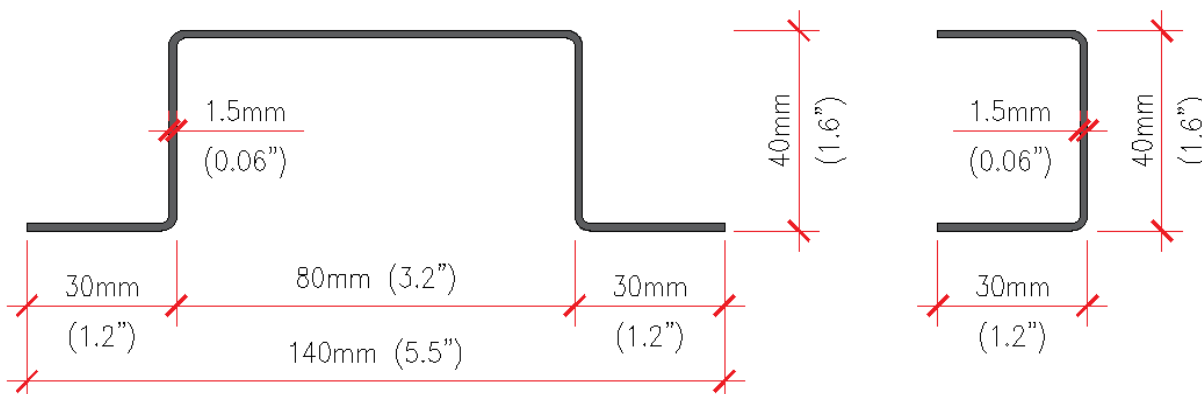

Figure 5.4 - Galvanised steel profiles

Minimum resistance of class DX51D (EN 10346)

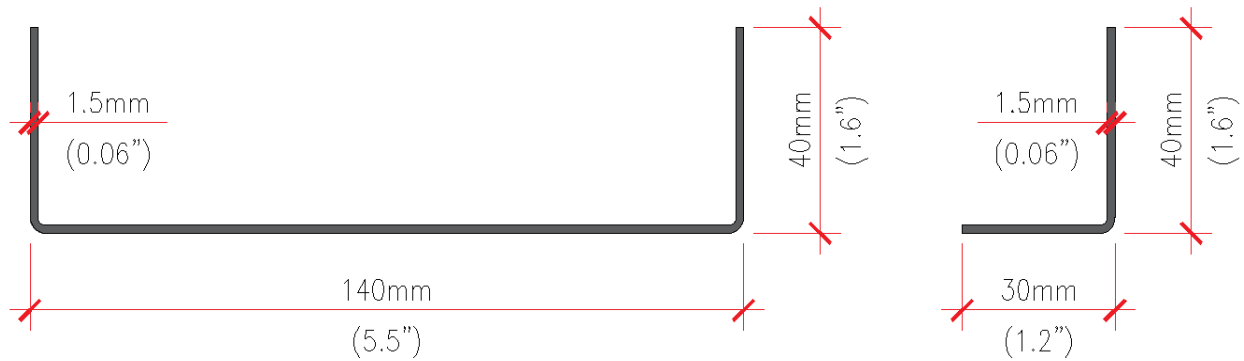

Figure 5.5 - Galvanised steel profiles (Alternative)
Minimum resistance of class DX51D (EN 10346)

The profile system used in plasterboard ceilings (T47 or similar) can be used if the Viroc panels are fixed with rivets (see figure 5.6), or if they have a thickness that guarantees the anchorage of the screws. In ceilings applied outdoors, the minimum thickness for fixing the screws is 1.5 mm; therefore these profiles are not suitable.

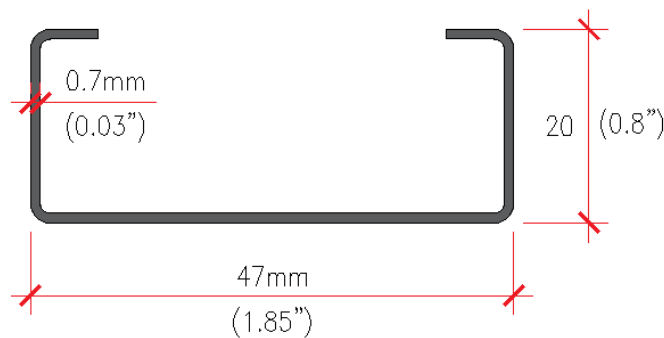

Figure 5.6 - T47 profile (minimum thickness: 0.7mm)
Galvanised steel: DX51D (Z+)

The support profiles must be dimensioned taking into account the deformations caused by the actions (self-weight, overloads, etc.), so that these do not jeopardise the normal functioning of the roof. Deformation due to action must not exceed the L/200 limit of the span between support fixings.

The width of the profiles must be such that the fixings can be positioned correctly, with the capacity to absorb small positioning errors, and the screw must not be less than 10 mm from the end.

The distance between profiles must respect the maximum distance between panel fixings, and the alignment of profiles between adjacent elements must be checked and must not differ by more than 2 mm.

5.3.3 Aluminium profiles

The aluminium profiles are fixed to the load-bearing structure using aluminium supporting squares, with metal anchors or anchors made up of metal screws and plastic bushings.

The aluminium used in the profiles must be at least a 6000 series alloy, with a yield strength $R_{p0.2}$ greater than 180 MPa.

The section of the profiles is generally T or L-shaped with a minimum thickness of 2 mm. Other section shapes can be used, provided they have the same performance and durability.

T-shaped profiles are used at the intersection of 2 panels. L-sections are used as intermediate supports and are also used to create single points on the façade (see figure 5.7).

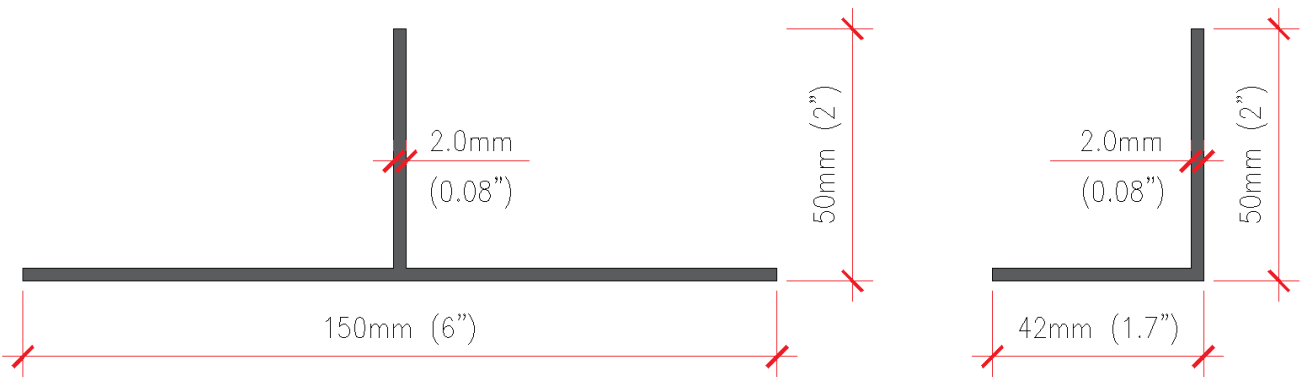

Figure 5.7 - Aluminium structure
6000 series alloy with $Rp0.2 \geq 180$ MPa

The support profiles must be dimensioned taking into account the deformations caused by the actions (self-weight, overloads, etc.), so that these do not jeopardise the normal functioning of the roof. Deformation due to action must not exceed the $L/200$ limit of the span between support fixings.

The width of the profiles must be such that the fixings can be positioned correctly, with the capacity to absorb small positioning errors, and the screw must not be less than 10 mm from the end.

The distance between profiles must respect the maximum distance between panel fixings; the alignment of profiles between adjacent elements must be checked and must not differ by more than 2 mm.

5.3.4 Supporting squares

The support structure can be fixed using galvanised steel or aluminium supporting squares, depending on the type of structure. Galvanised steel supporting squares can be used with wooden or galvanised steel frames, while aluminium supporting squares can be used with aluminium profiles.

5.3.5 Threaded rod + pivots

The support structures used in the plasterboard panels consist of threaded rods fixed to the ceiling with bushings and pivots to the metal profiles (see figures 5.8 and 5.9).

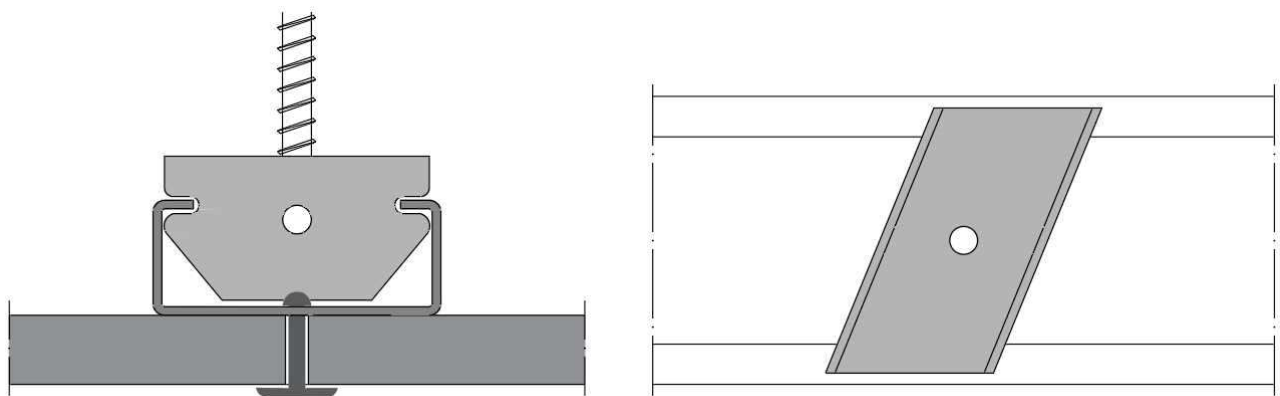

Figure 5.8 - Detail of panel attachment to support profile

When fastening with rivets, it is necessary to use a spacer, which is placed on the head of the riveting machine so as to leave a gap of 0.5 mm between the surface of the panel and the back of the rivet head. This free space is used to create a gap and allow for dimensional variations in the panels (see figure 5.11).



Figure 5.11 - Torque limiting knobs, to be placed on the riveting head

To make it easier to place the screws or rivets in the centre of the bolt holes, auxiliary tools can be used (see figures 5.12 and 5.14).



Figure 5.12 – Screw-centering spanner
SFS Intec



Figure 5.13 - bolt hole centering spanner
SFS Intec: ZL, ETANCO: ML 1000

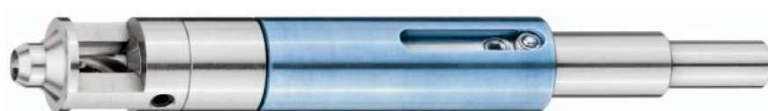

Figure 5.14 – bolt hole centering tool, SFS Intec

5.4.2 Indoors

In indoor applications, if the temperature and moisture variations are not important, the panels can be fixed only with supports, making fixing work easier.

The panels can always be drilled with the same bolt holes diameter, 5 or 5.5 mm depending on the diameter of the screws, whether they are located in the centre of the panel or on the periphery.

The fixings near the periphery of the panels are made at a distance of 50 to 75 mm (see figure 5.15).

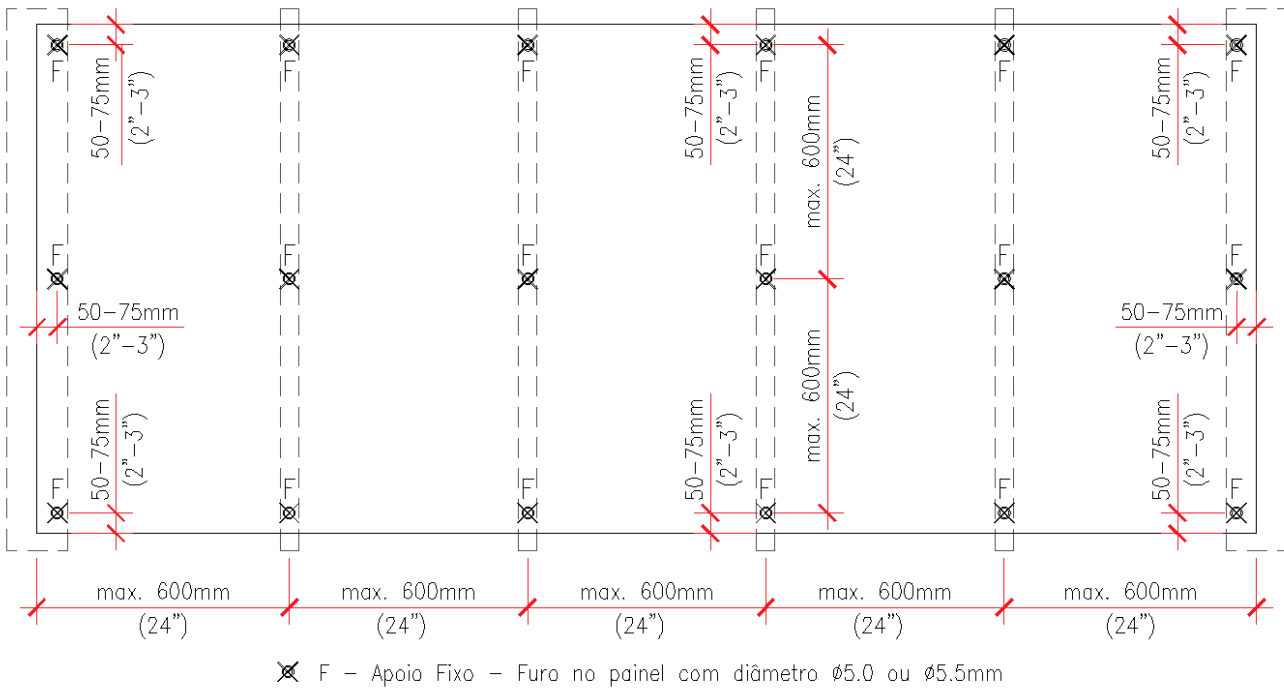

Figure 5.15 - Ceiling panel fixings, applied indoor

5.5 Surface treatment

Panels applied outdoors must be protected with paint or varnish.

Before applying the varnish to the panels, the surfaces must be completely clean and dry, with no grease, dust or salts. Cleaning can be done by polishing with cleaning disks. VIROC Portugal has suitable disks that it can supply on request. Alternatively, the surfaces can be cleaned using sandpaper with a fine-grained disk equal to or greater than 120.

5.6 Paints and varnishes

There are no specific paints or varnishes to be applied to Viroc. The panel has a surface alkalinity (PH) of 11 to 13, so paints and varnishes suitable for concrete and wood surfaces at the same time are usually the best when applied to Viroc panel.

Paints and varnishes made from acrylic resins or solvent-based aliphatic polyurethanes are the ones that have shown the best performance.

Water-based acrylic resin or aliphatic polyurethane varnishes have the least effect on the panel original colour.

Generally speaking, varnishes are easy to apply, but it is very important to bear in mind that the application must be continuous and constant, to guarantee the homogeneity of the finish on the panel and so that the surface doesn't become stained and have different shades. Panels must always be painted/varnished on both sides and tops. The application procedures provided by the manufacturers must always be followed for the recommended coats.

5.7 Joints between panels

The joints between panels should have a gap of 2 to 3 mm when applied indoors and 5 mm when applied outdoors.

5.8 Ceiling type sections

Figures 5.16, 5.17, 5.18 and 5.19 show roof sections made with different types of structure.

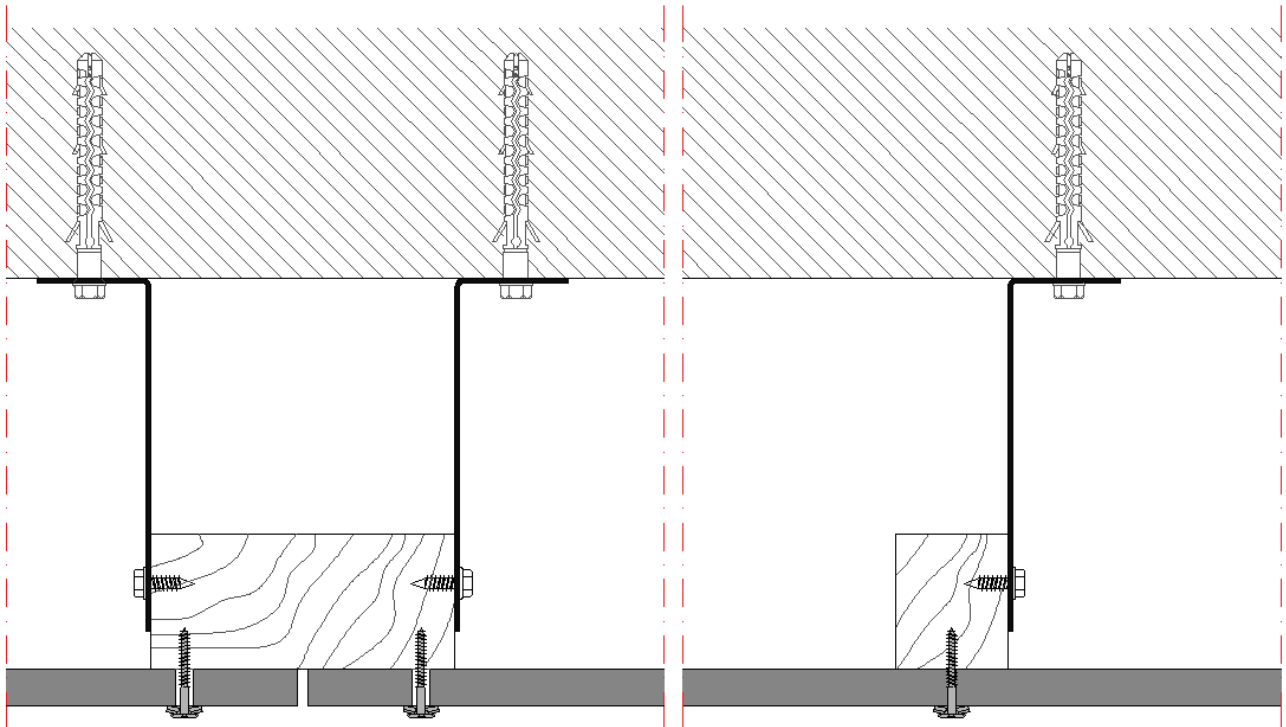

Figure 5.16 - Roof with wooden structure

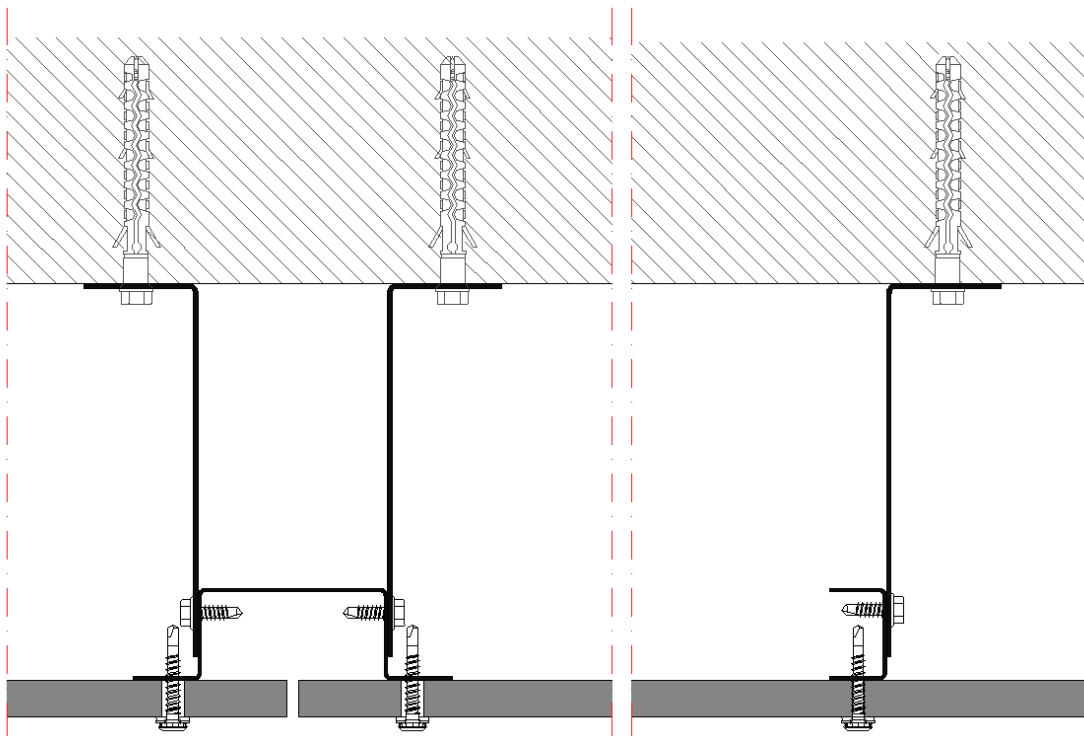

Figure 5.17 - Roof with galvanised steel structure

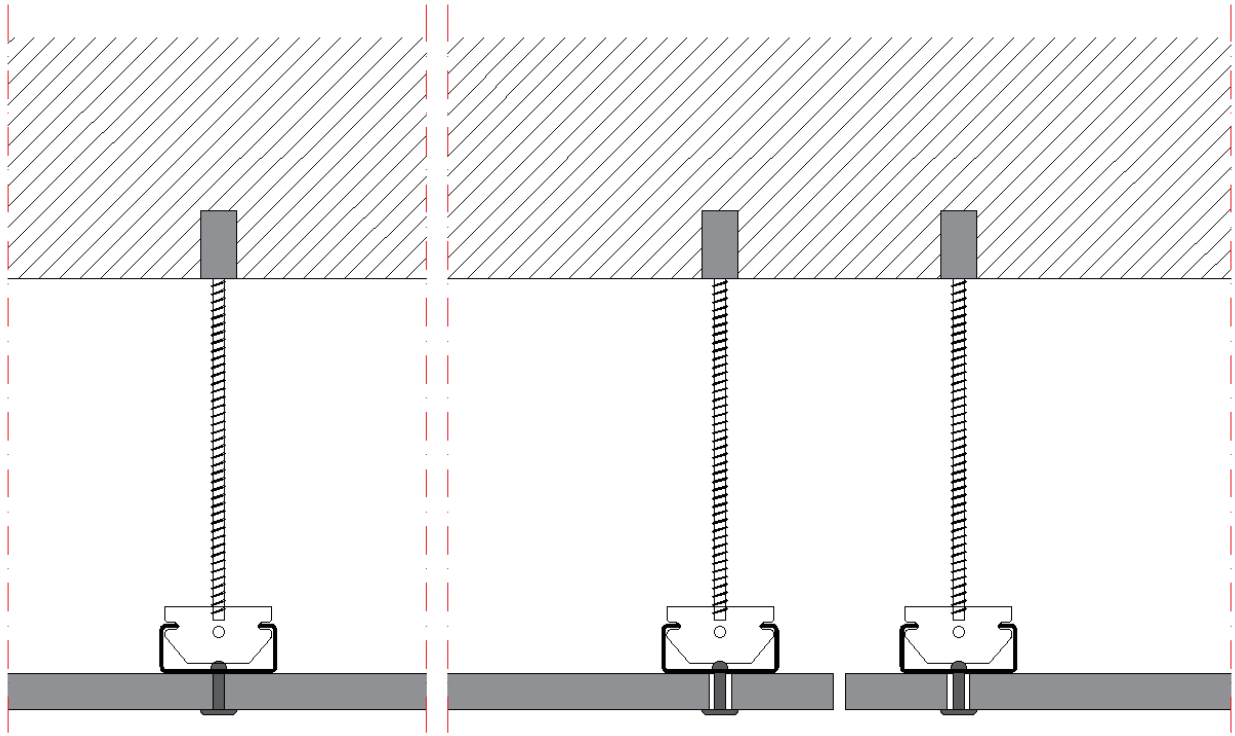

Figure 5.18 - Roof with galvanised steel TC structure

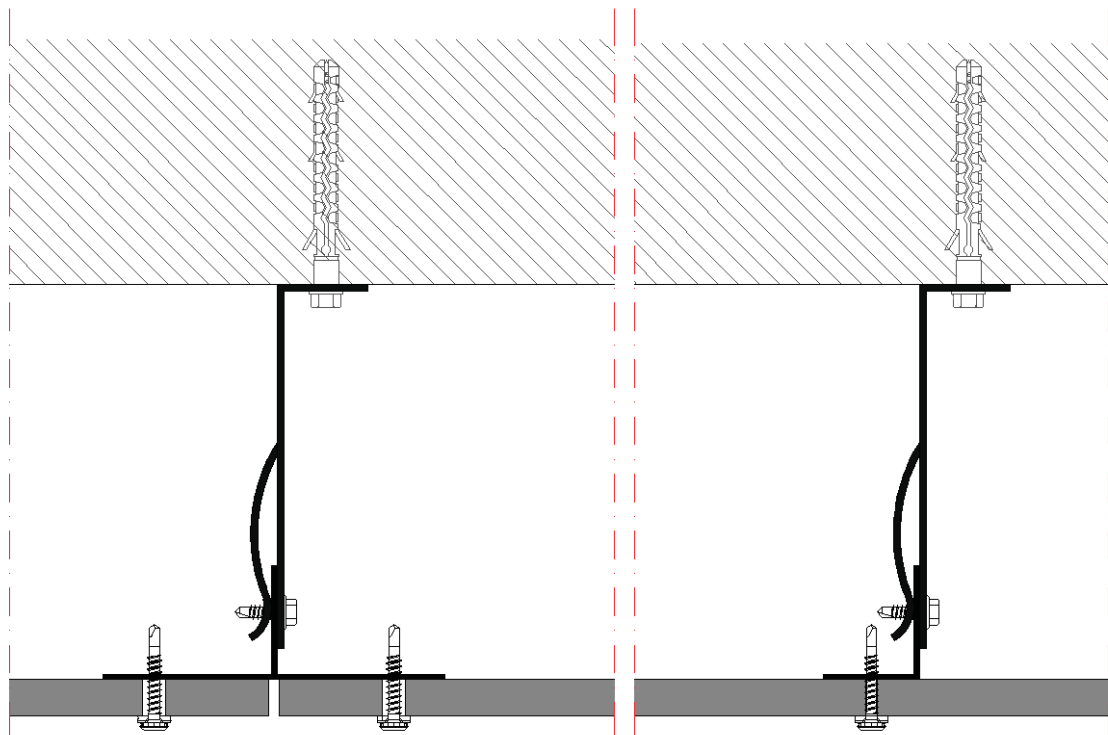

Figure 5.19 - Roof with aluminium structure

5.9 Acoustic performance

Viroc Portugal carried out some sound absorption tests, the performance of which has been characterised, with the geometry of the panels as shown in figures 5.20 and 5.21.

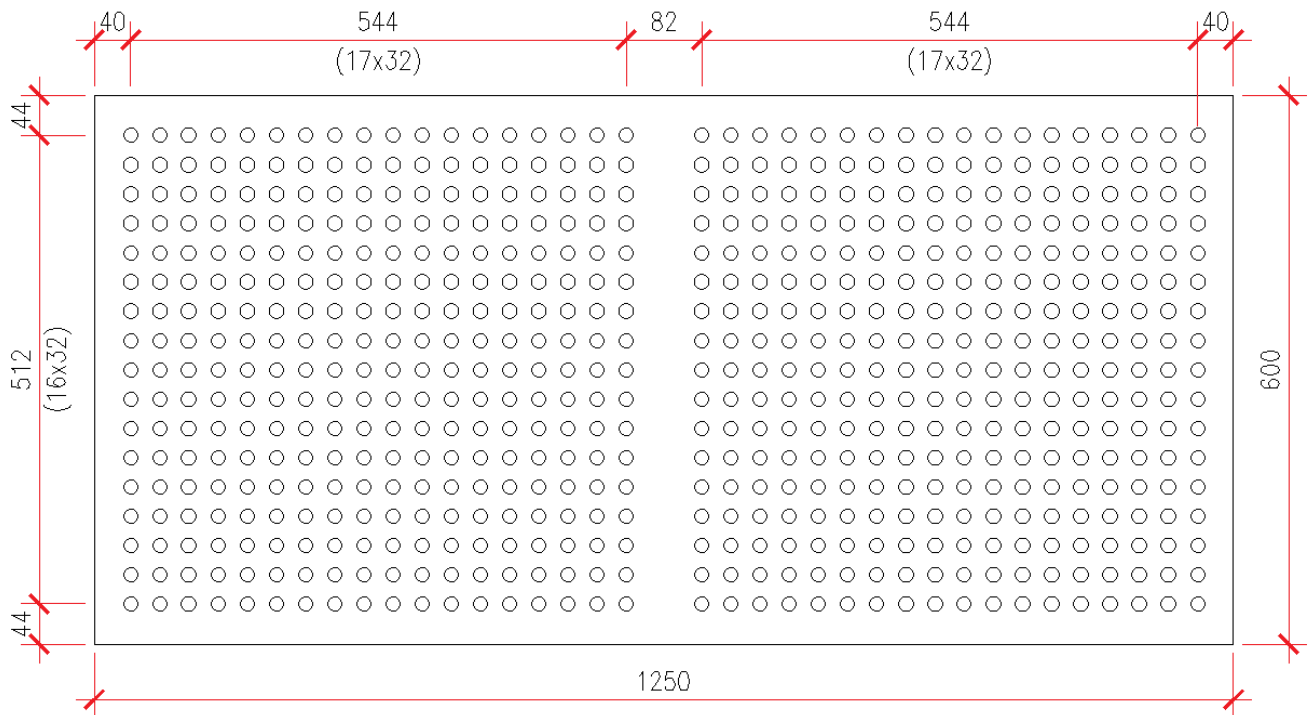

Figure 5.20 - Panel 1250x600 mm, with 12 mm diameter holes 32 mm apart between the axes

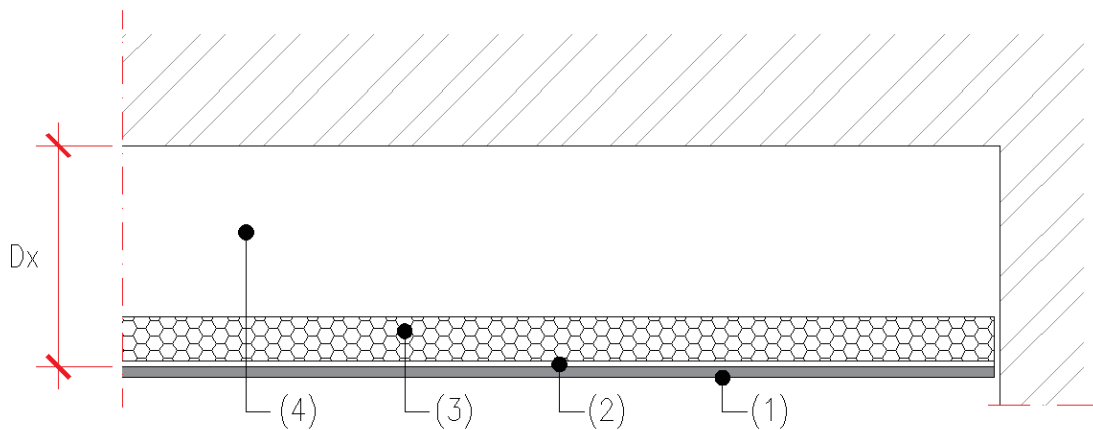
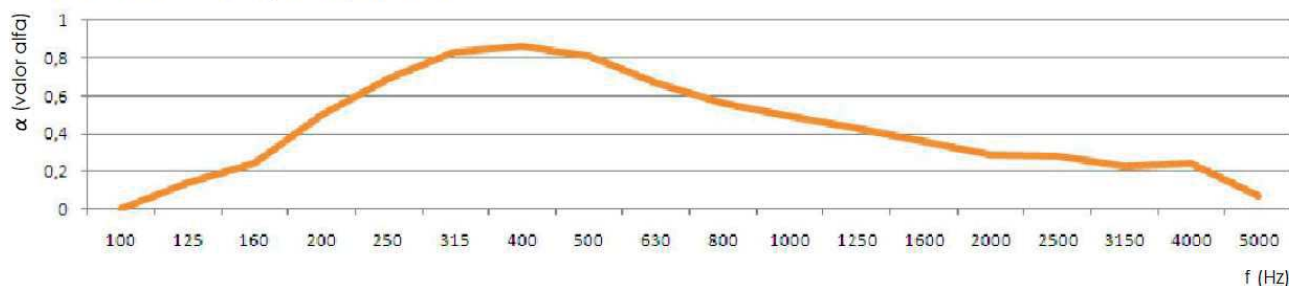

Figure 5.21 - Ceiling section, from the experimental tests carried out to determine the sound absorption index

- 1) Viroc panel
- 2) Acoustic felt
- 3) Rock wool, thickness 40 mm, density 30 Kg/m³
- 4) Air gap, Dx =100, 200 and 400 mm

5.9.1 Ceiling with 100 mm box (Dx=100 mm)

ÍNDICE DE ABSORÇÃO SONORA



f (Hz)	100	125	160	200	250	315	400	500	630	800	1000	1250	1600	2000	2500	3150	4000	5000
α (alfa)	0.00	0.14	0.24	0.50	0.69	0.83	0.86	0.81	0.67	0.56	0.49	0.43	0.36	0.29	0.28	0.23	0.24	0.07

5.9.2 Ceiling with 200 mm box (Dx=200 mm)

ÍNDICE DE ABSORÇÃO SONORA

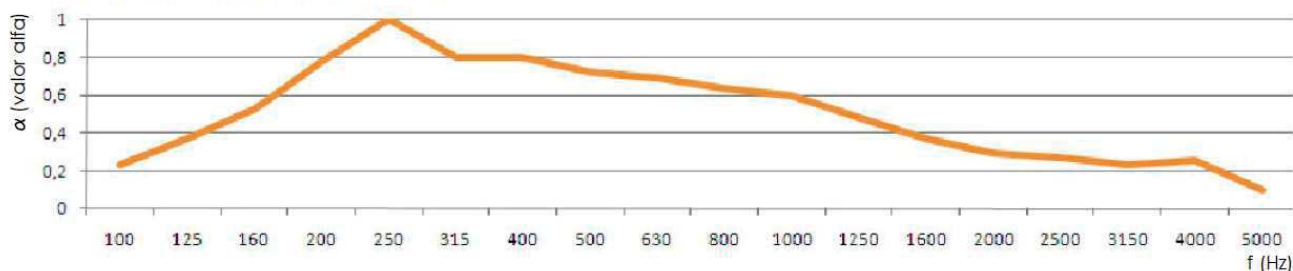

f (Hz)	100	125	160	200	250	315	400	500	630	800	1000	1250	1600	2000	2500	3150	4000	5000
α (alfa)	0.23	0.37	0.53	0.78	1.00	0.80	0.80	0.72	0.69	0.64	0.60	0.48	0.37	0.29	0.27	0.23	0.25	0.10

5.9.3 Ceiling with 400 mm box (Dx=400 mm)

ÍNDICE DE ABSORÇÃO SONORA

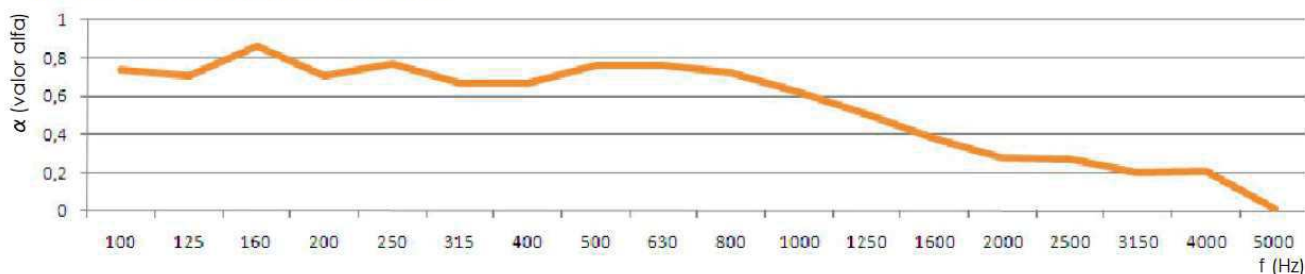

f (Hz)	100	125	160	200	250	315	400	500	630	800	1000	1250	1600	2000	2500	3150	4000	5000
α (alfa)	0.74	0.71	0.86	0.71	0.77	0.67	0.67	0.76	0.76	0.72	0.62	0.50	0.38	0.28	0.27	0.20	0.21	0.01